

# ***SERVICE MANUAL***

---

Air Suction Paper Folder

## **DF-1000**

# **Duplo**

**Feb. 2006**

**Revision 0**

**Purpose**

This manual describes technical specifications of the product for service persons to understand the operational principles of the product so that they can carry out appropriate maintenance and repair work on the market.

This manual provides information applying to all countries in which the product is sold as well as information which may not apply to certain countries.

**Revision**

The information contained in this manual is subject to change due to product improvement, etc.

When information is changed, this manual will also be revised.

Please check with quality service information issued as required until the manual is revised.

**Trademark**

The product name and company name used in this manual are the trademark or registered trademark of the respective companies.

**Note**

This manual must be handled with extreme caution, particularly ensure against leakage of technical details.

## **PREFACE**

Most accidents occur due to the failure to observe basic safety rules and precautions. To prevent accidents, it is important to prevent their causes. Service persons of this product (hereafter referred to as SP) must therefore attend servicing skill seminars before carrying out servicing and read this manual thoroughly to fully understand safety precautions, appropriate servicing procedures and methods.

Failure to do so will result in unexpected accidents.

Since it is not possible to list all imaginable dangers which may occur during servicing, the SP must carry out servicing with extreme care to ensure safety at all times, in addition to observing the precautions labeled on the product and indicated in this manual.

# **1 ORGANIZATION OF THIS MANUAL**

This manual describes information required for carrying out servicing work of this product in the following chapters.

**Chapter 1 INTRODUCTION:**

Provides information for the user such as system configuration, features, specifications, names of parts, user menu, user maintenance, etc.

**Chapter 2 OPERATIONS:**

Describes the mechanism/control methods of the whole product and each part.

**Chapter 3 DISASSEMBLY/ASSEMBLY:**

Describes the parts to be replaced regularly, consumables, recommended spare parts, boards, and disassembly/assembly procedures of main units.

**Chapter 4 MAINTENANCE/INSPECTION:**

Lists tools/solvents/lubricants required for servicing work, lists parts to be replaced regularly, consumables, and recommended spare parts, and describes periodic servicing methods.

**Chapter 5 STANDARDS/ADJUSTMENTS:**

Describes mechanical and electrical adjustment methods and standard values.

**Chapter 6 MAINTENANCE MODE:**

Describes check menus for servicing work, simulation modes, procedures for checking operations of electrical parts, procedures for upgrading version, etc.

**Chapter 7 TROUBLESHOOTING:**

Describes troubleshooting methods when expected processing results are not obtained, error messages, and methods for resolving malfunctions.



**Appendix:**



Contains menu maps, electrical parts layout, board layout, overall schematic diagrams, and wiring diagrams.

This manual does not describe disassembly/assembly procedures for all parts. For details on parts not listed in this manual, please refer to the separate “Parts Catalog”.

## 2 SAFETY PRECAUTIONS

In this manual, operations and handling of the unit which are hazardous are described using the following marks to prevent personal injury or property damage to the user and others.



 <b>WARNING</b>	<b>Ignoring this mark could result in the possibility of serious injury or even death.</b>
 <b>CAUTION</b>	<b>Ignoring this mark could result in the possibility of injury or physical damage.</b>

	<p><b>This mark indicates a “Warning” or “Caution”.</b> A graphic may be shown inside the mark to describe the warning or caution more specifically.</p>
	<p><b>This mark indicates a forbidden action.</b> A graphic may be shown inside the mark to describe the forbidden action more specifically.</p>
	<p><b>This mark indicates actions that must be performed.</b> A graphic may be shown inside the mark to describe the action to be performed more specifically.</p>

### 2.1 Power Supply

Make sure the power supply used is always within the following range.

- Power supply : AC 120 V 60 Hz (USA model), AC 220 to 240 V 50/60 Hz (UK model)
- Rated current (Rated power) : 2 to 1 A (140 W)

 <b>WARNING</b>	
	<p><b>Use only the power supply voltage specified on the main nameplate.</b> Using other voltages could result in a fire or an electrical shock.</p>
	<p><b>Make sure that the combined power consumption of the appliances to be connected does not exceed the capacity rating of the power outlets or plug receptacles.</b> Exceeding the capacity rating could cause the power outlets, plug receptacles, or power extension cords to overheat and catch a fire.</p>

 **CAUTION**



**Do not place anything around the socket-outlet to ensure that the power plug can be disconnected anytime.**

If the power plug cannot be disconnected immediately when product failure occurs, it could result in fire or an electric shock.



**This unit shall be installed near the socket-outlet where the plug on the power supply cord is easily accessible.**

If the power plug cannot be disconnected immediately when product failure occurs, it could result in fire or an electric shock.

## 2.2 Operating Environment

Operate this unit in the following environment.

- where the temperature range is between 5 and 35°C (-10 to +50°C in storage)
- where the humidity range is between 20 and 80% RH (10 to 90% RH in storage, however no condensation)

 **WARNING**



**Keep this unit and the power cord away from heaters and heater vents.**

Excessive heat could melt the cover or power cord covering, and result in a fire or an electrical shock.



**Do not place metal objects or vessels containing liquids on top of the unit.**

The entry of any metal object or liquid could result in a fire or an electrical shock.



**Do not insert any metal or easily-combustible object inside this unit.**

This could result in a fire or an electrical shock.

 **CAUTION**



**Do not install the unit in the following environment.**

Otherwise it may cause fire or an electric shock.

- where the temperature is high
- where the unit will be subject to direct sunlight
- near fire
- where it is considerably dusty
- where there is considerable vibration
- where there is considerable air-borne salt
- where there are harmful chemicals



**Do not install this unit in a location where there is excessive humidity or where contact with water is possible.**

Poor choice of location could result in deterioration of the insulation, a fire or an electrical shock.



**Do not install the unit near devices which emit strong magnetic force and in magnetic fields.**

Otherwise incorrect operations and malfunctions may occur.



**Install this unit on a level, stable stand or floor, with sufficient space around it.**

Failure to do so could result in the unit overturning and causing injury.

## CAUTION



**Disconnect the power plug from the power outlet before attempting to move this unit.**

Failure to do so could result in power cord damage, a fire or an electrical shock.



**Always disconnect the power plug from the power outlet when the unit is not to be used for an extended period.**

Failure to do so could result in a fire due to leakage current if the insulation should deteriorate.

## 2.3 Maintenance, etc.

## WARNING



**Do not damage the power cord or power plug.**

Do not scratch, alter, bend, twist, pull or place heavy objects on the power cord or power plug.  
This could result in damage, a fire or an electrical shock.



**Do not handle the power plug with wet hands.**

This could result in an electrical shock.



**Do not use flammable sprays inside or near the unit (e.g. when cleaning the unit).**

Such flammable gas may ignite and cause a fire or combustion.  
Take precautions against fire and ensure ventilation when using alcohol, and store the alcohol in a safe place after use. Also note that use of other solvents can damage the rubber rollers and resin inside the unit, resulting in malfunctions.



**If any foreign object such as metal or liquid should enter this unit, immediately turn the unit off at the power switch and disconnect the power plug from the power outlet.**

Failure to do so could result in a fire or an electrical shock.



**Before cleaning this unit, turn the unit off at the power switch and disconnect the power plug from the power outlet.**

Accidental operation of the unit during cleaning could result in injury.



**Before beginning servicing work, turn the unit off at the power switch and disconnect the power plug from the power outlet.**

Accidental operation of the unit during servicing could result in injury.  
If removing covers to check operations, be very careful to ensure that hands and clothing are not drawn into movable parts.



**Remove any dust that accumulates on the power plug prongs and the surface of the plug from which the prongs extend.**

Accumulated dust could result in a fire.



**Always grip the plug when disconnecting the power plug from the power outlet.**

Forcibly pulling on the power cord could cause damage, resulting in a fire or an electrical shock.

 **WARNING**



**Do not disassemble the product unnecessarily.**

Disassembly of parts not specified in this manual, parts catalog, and technical information may cause fire, electric shock, injury, incorrect operations, and malfunctions.



**Do not disable the product safety function.**

Safety functions are provided to protect the user and product. Do not remodel the product so as to disable the safety functions.



**Do not touch or insert foreign objects into any rotating part during operation.**

This could result in injury.

 **CAUTION**



**Prior to servicing, be sure to read this manual and all technical information.**



**Perform servicing work in safety working wear and using the specified tools, solvents, and lubricants.**



**To prevent static electric damage of electrical parts, prior to servicing, touch metal tools that are properly grounded to eliminate static electricity accumulated in the human body.**

Static electricity may accumulate in the human body during contact with clothing. This static electricity may damage electrical devices or change the electrical characteristics of devices.





## 2.4 Warning and Caution Label Locations

### NOTE

The warning and caution labels are pasted or printed on the unit to ensure the safety of users.

Do not remove nor change them.

If these labels become dirty or damaged, replace with new ones.

⚠ CAUTION	⚠ 注意
  	<p><b>Do not put fingers inside during operation.</b>  <b>Keep away long hair, ties, jewelry and loose clothing.</b>  <b>It could cause injury.</b></p>
	<p>運転中は機械内部に絶対手や指を入れてください。          髪の毛、ネクタイ、装身具、長い袖等を垂らさないでください。          巻き込まれてケガをする恐れがあります。</p>

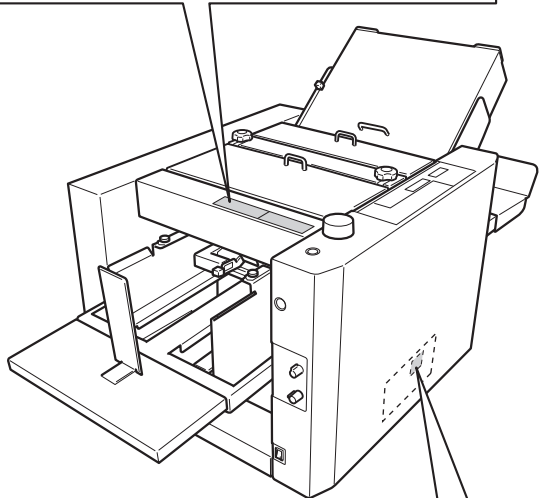

Caution Label for SP

### CAUTION

FOR CONTINUED PROTECTION  
 AGAINST RISK OF FIRE,  
 REPLACE ONLY WITH SAME TYPE  
 AND RATING OF FUSE

## **3 ENVIRONMENTAL PRESERVATION**

### **3.1 Collection of This Unit**

Please collect/disassemble, recycle, or dispose unwanted products in accordance with the requirements of each country and region.

### **3.2 Collection of Consumables and Parts**

Please collect/disassemble, recycle, or dispose unwanted consumables and parts in accordance with the requirements of each country and region.

Please handle the following parts with particular care as they are subject to regulations of each country and are difficult to sort (complex materials) by material.

- Batteries
- LCD
- Boards
- Power cords, I/F cables, cables such as bundled wire units
- Electrical parts such as sensors, switches, motors, clutches, solenoids, etc.

**Preface** ..... i

**1 Organization of This Manual**..... ii

**2 Safety Precautions** ..... iii

2.1 Power Supply ..... iii

2.2 Operating Environment..... iv

2.3 Maintenance, etc. .... v

2.4 Warning and Caution Label Locations..... vii

**3 Environmental Preservation** ..... viii

3.1 Collection of This Unit..... viii

3.2 Collection of Consumables and Parts ..... viii

## **Chapter 1 INTRODUCTION**

**1 Features** ..... 1-2

**2 Specifications** ..... 1-3

2.1 Type and Method ..... 1-3

2.2 Performance and Functions ..... 1-3

2.2.1 Processing performance ..... 1-3

2.2.2 Functions ..... 1-5

2.3 Paper ..... 1-6

2.4 Others ..... 1-7

2.4.1 Power supply/dimensions/mass (weight) ..... 1-7

2.4.2 Error detection functions ..... 1-7

**3 Names of Parts**..... 1-8

3.1 External Parts ..... 1-8

**4 Control Panel** ..... 1-10

4.1 Control Panel ..... 1-10

4.2 User Menu (Function Setting Mode)..... 1-11

**5 User Adjustments** ..... 1-13

5.1 List of Adjustments ..... 1-13

5.2 Paper Feed Adjustments ..... 1-13

5.2.1 Skew correction by side guide adjusting knob ..... 1-13

5.2.2 Skew correction by skew correction knob ..... 1-14

5.2.3 Using the skew roller spring pressure adjusting knob ..... 1-14

5.3 Folding Position Adjustments ..... 1-15

5.3.1 Folding position correction by folding mode ..... 1-15

5.4 Paper Ejection Adjustments ..... 1-17

5.4.1 Changing the stacker roller position..... 1-17

5.4.2 Changing the stacker roller height ..... 1-18

**6 User Maintenance** ..... 1-19

6.1 List of Maintenance Items..... 1-19

6.2 Cleaning by User ..... 1-19

6.2.1 Cleaning the sensors ..... 1-19

6.2.2 Cleaning the suction belts ..... 1-21

6.2.3 Cleaning the folding rollers ..... 1-21

6.2.4 Cleaning the stacker belts ..... 1-22

6.3 Replacement by User ..... 1-22

## **Chapter 2 OPERATIONS**

**1 Outline** ..... 2-2

1.1 Function Configuration ..... 2-2

1.2 Block Diagram of Structure..... 2-3

1.3 Basic Operations ..... 2-6

1.3.1 Operations at power ON ..... 2-6

1.3.2 Operations at power OFF ..... 2-6

1.3.3 Operation during processing ..... 2-6

1.3.4 Stopping operations when problems occur ..... 2-7

**2 External Cover/Control Section**..... 2-8

2.1 Power Supply ..... 2-8

2.1.1 Outline ..... 2-8

2.1.2 Safety function..... 2-8

2.2 Main Motor Control ..... 2-10

2.2.1 Outline ..... 2-10

2.2.2 Operations ..... 2-10

2.3 Counter ..... 2-11

2.3.1 Outline ..... 2-11

2.3.2 Operations ..... 2-11

**3 Paper Feed Section** ..... 2-12

3.1 Outline ..... 2-12

3.1.1 Configuration..... 2-12

3.1.2 Paper feed operations..... 2-13

3.2 Paper Feed Tray Section..... 2-14

3.2.1 Outline ..... 2-14

3.2.2 Side guide section..... 2-14

3.2.3 Tray up/down section ..... 2-16

3.3 Suction Conveyance Section..... 2-17

3.3.1 Outline ..... 2-17

3.3.2 Separator section..... 2-17

3.3.3 Suction section..... 2-18

3.3.4 Conveyance section ..... 2-20

3.4 Registration Section ..... 2-21

3.4.1 Outline ..... 2-21

3.4.2 Registration control (Skew correction)..... 2-21

**4 Folding Section**..... 2-23

4.1 Outline ..... 2-23

4.1.1 Configuration..... 2-23

4.1.2 Folding operations..... 2-23

4.2 Folding Plate Section..... 2-26

4.2.1 Outline ..... 2-26

4.2.2 Folding stopper sections of folding plates 1 and 2..... 2-26

## CONTENTS

---

4.3 Folding Roller Section .....	2-28	3.1.3 Removing the folding plate index sensors (PS1, PS2, PS4, PS5) .....	3-8
4.3.1 Configuration .....	2-28	3.1.4 Removing the folding plate home sensors (PS3, PS6) .....	3-9
<b>5 Paper Ejection Section .....</b>	<b>2-29</b>	<b>3.2 Folding Roller Section .....</b>	<b>3-9</b>
5.1 Outline .....	2-29	3.2.1 Removing the folding rollers .....	3-9
5.1.1 Configuration .....	2-29	<b>4 Paper Ejection Section .....</b>	<b>3-11</b>
5.1.2 Paper ejection operations .....	2-29	<b>4.1 Stacker Unit .....</b>	<b>3-11</b>
5.2 Stacker Belt Section .....	2-30	4.1.1 Removing the stacker unit .....	3-11
5.2.1 Configuration .....	2-30	4.1.2 Removing the stacker roller home sensor (PS11) .....	3-11
5.2.2 Stacker belt drive .....	2-30	4.1.3 Removing the stacker roller moving motor (MOT5) .....	3-11
5.3 Stacker Roller Section .....	2-31	4.1.4 Removing the stacker belts .....	3-11
5.3.1 Configuration .....	2-31		
5.3.2 Lever unit drive .....	2-31		

---

## **Chapter 3 DISASSEMBLY/ ASSEMBLY**

---

<b>1 External Cover/Control Section .....</b>	<b>3-2</b>
1.1 External Cover Section .....	3-2
1.1.1 External cover .....	3-2
1.2 Control Panel Section .....	3-3
1.2.1 Removing the control panel .....	3-3
1.3 Board .....	3-3
1.3.1 Removing the MC unit .....	3-3
1.4 Power Supply/Drive .....	3-4
1.4.1 Removing the switching power supply .....	3-4
1.4.2 Removing the main motor (MOT1) .....	3-4
1.4.3 Removing the paper feed tray motor .....	3-5
<b>2 Paper Feed Section .....</b>	<b>3-6</b>
2.1 Paper Feed Tray Section .....	3-6
2.1.1 Removing the PS P.W.B. unit .....	3-6
2.2 Suction Conveyance Section .....	3-6
2.2.1 Removing the suction conveyance unit .....	3-6
2.2.2 Removing the suction belts .....	3-6
2.3 Registration Section .....	3-7
2.3.1 Removing the registration clutch (CLH3) .....	3-7
2.3.2 Removing the registration brake (BRK1) .....	3-7
2.3.3 Removing the registration secondary roller .....	3-7
2.3.4 Removing the registration roller .....	3-7
<b>3 Folding Section .....</b>	<b>3-8</b>
3.1 Folding Plate Section .....	3-8
3.1.1 Removing the folding stoppers .....	3-8
3.1.2 Removing the folding plate stopper motors (MOT2, MOT3) .....	3-8

## **Chapter 4 MAINTENANCE/ INSPECTION**

---

<b>1 List of Maintenance Tools .....</b>	<b>4-2</b>
1.1 General Tools .....	4-2
1.2 Special Tools .....	4-2
<b>2 Product Lifespan/Parts Lifespan .....</b>	<b>4-3</b>
2.1 Product Lifespan .....	4-3
2.2 Parts Lifespan .....	4-3
2.2.1 Recommended spare parts A (Consumables) .....	4-3
2.2.2 Recommended spare parts B (Function parts) .....	4-3
2.2.3 Recommended spare parts C (Drive parts) .....	4-3
2.2.4 Recommended spare parts D (Semi-durable parts) .....	4-3
<b>3 Periodic Maintenance .....</b>	<b>4-4</b>
3.1 Basic Maintenance .....	4-4
3.2 Cleaning .....	4-4
3.3 Oiling .....	4-4

# Chapter 5 STANDARDS/ ADJUSTMENTS

<b>1 Basic Adjustment Procedures.....</b>	<b>5-2</b>
<b>2 External Cover/Control Section.....</b>	<b>5-3</b>
2.1 External Cover Section.....	5-3
2.1.1 Adjusting the interlock switch position.....	5-3
2.2 Drive Section.....	5-4
2.2.1 Adjusting the tention of the timing belt.....	5-4
2.2.2 Attaching position of motor pulley.....	5-5
<b>3 Paper Feed Section.....</b>	<b>5-6</b>
3.1 Paper Feed Tray Section.....	5-6
3.1.1 Adjusting the paper feed tray position.....	5-6
3.1.2 Adjusting the side guide.....	5-8
3.2 Suction Conveyance Section.....	5-9
3.2.1 Adjusting the separating air adjusting knob position.....	5-9
3.2.2 Adjusting the separator adjusting knob position.....	5-9
3.2.3 Adjusting the suction conveyance unit position.....	5-10
3.2.4 Adjusting paper feed tray sensor 1 (PS7) position.....	5-10
3.2.5 Adjusting the suction solenoid (SOL1) position.....	5-11
3.2.6 Adjusting paper feed tray sensor 2 (PS9) position.....	5-11
<b>4 Folding Section.....</b>	<b>5-12</b>
4.1 Folding Plate Section.....	5-12
4.1.1 Adjusting the parallelity of the folding stopper.....	5-12
4.1.2 Adjusting the home position of the switching shaft.....	5-14
4.1.3 Adjusting the home position of the folding stopper.....	5-15
4.1.4 Checking the conveyance path gap of folding plate.....	5-16
4.1.5 Adjusting the gap of the screw shaft unit.....	5-16
4.1.6 Adjusting the motor deceleration pulley section.....	5-17
4.1.7 Adjusting the folding stopper section.....	5-18
4.1.8 Adjusting the attaching position of the switching adjusting plate.....	5-18
4.2 Folding Roller Section.....	5-19

4.2.1 Adjusting the attaching position of the press spring T.....	5-19
4.2.2 Adjusting the gap of folding roller 1.....	5-19
4.2.3 Checking the folding roller nip.....	5-20
4.2.4 Adjusting the attaching position of the conveyance plate.....	5-21
4.2.5 Adjusting the connecting plate.....	5-21
<b>5 Paper Ejection Section.....</b>	<b>5-22</b>
5.1 Stacker Belt Section.....	5-22
5.1.1 Adjusting the tention of the stacker belt.....	5-22
5.2 Stacker Roller Section.....	5-22
5.2.1 Adjusting the tention of the timing belt.....	5-22
5.2.2 Adjusting the stacker roller home sensor (PS11) position.....	5-22

# Chapter 6 MAINTENANCE MODE

<b>1 Outline.....</b>	<b>6-2</b>
<b>2 Maintenance Mode Operations.....</b>	<b>6-3</b>
2.1 Entering the Maintenance Mode.....	6-3
2.2 Exiting the Maintenance Mode.....	6-3
<b>3 Menus and Functions.....</b>	<b>6-4</b>
3.1 Menu List.....	6-4
3.2 Other Functions.....	6-10
3.2.1 Setting the paper feed tray sensor 2 (PS9) to OFF.....	6-10
<b>4 Upgrading the Program Version.....</b>	<b>6-11</b>
4.1 Outline.....	6-11
4.1.1 Preparing the rewriting tool (EPROM).....	6-11
4.2 Upgrading the Version.....	6-11
4.2.1 Upgrading the program version.....	6-11
<b>5 Data Initialization.....</b>	<b>6-12</b>
5.1 Erasing Standard Folding Correction/ Custom Folding Data.....	6-12
5.2 Initializing the EEPROM.....	6-12

# **Chapter 7**

## **TROUBLESHOOTING**

<b>1 Outline .....</b>	<b>7-2</b>
<b>2 Troubleshooting by Phenomenon .....</b>	<b>7-3</b>
2.1 Paper Feed Problems .....	7-3
2.1.1 Mis-feed .....	7-3
2.1.2 Continuous-feed .....	7-3
2.2 Folding Problems .....	7-3
2.2.1 Folding misalignment along vertical length of paper .....	7-3
2.2.2 Folding misalignment along sides of paper .....	7-4
2.2.3 When paper is not folded at the normal position .....	7-4
<b>3 Troubleshooting by Message Displayed .....</b>	<b>7-5</b>
3.1 Paper Jam Messages .....	7-5
3.1.1 When "JAM FEED SECT" is displayed .....	7-5
3.1.2 When "JAM INSIDE" is displayed .....	7-5
3.1.3 When "JAM EXIT" is displayed .....	7-5
3.2 Error Messages .....	7-6
3.2.1 When "F.PLATE SET ERR" is displayed .....	7-6
3.2.2 When "FEED ERROR" is displayed .....	7-6
3.3 Trouble Messages .....	7-7
3.3.1 When "MOTOR ERROR 1" is displayed .....	7-7
3.3.2 When "MOTOR ERROR 4" is displayed .....	7-7
3.3.3 When "MOTOR ERROR 5" is displayed .....	7-7
3.3.4 When "MOTOR ERROR 3" is displayed .....	7-8
3.3.5 When "MOTOR ERROR 2" is displayed .....	7-8
3.3.6 When "TRAY UP ERROR" is displayed .....	7-9
3.3.7 When "TRAY DOWN ERROR" is displayed .....	7-9
3.4 Other Messages .....	7-10
3.4.1 When "NO PAPER" is displayed .....	7-10
3.4.2 When "TOP COVER-L OPEN" is displayed .....	7-10
3.4.3 When "TOP COVER-R OPEN" is displayed .....	7-10
3.4.4 When "SIDE COVER OPEN" is displayed .....	7-10
<b>4 Troubleshooting for Operation Failures .....</b>	<b>7-11</b>

4.1 Power Does Not Turn ON .....	7-11
4.2 Nothing is Displayed on Control Panel .....	7-11
4.3 Key Operations are Disabled on Control Panel .....	7-12
4.4 Mis-detection of Standard Paper Sizes Occurs .....	7-12

## **Appendix**

<b>1 List of Displayed Messages .....</b>	<b>A-2</b>
1.1 No Paper .....	A-2
1.2 Key Input Error .....	A-2
1.3 Cover Open .....	A-2
1.4 Paper Jam/Error .....	A-2
1.5 Trouble .....	A-3
<b>2 Layout of Electrical Parts .....</b>	<b>A-4</b>
2.1 Front of Unit .....	A-4
2.2 Back of Unit .....	A-5
2.3 Inside Unit .....	A-6
2.4 Paper Feed Section .....	A-7
2.5 Folding Plate Section .....	A-8
2.6 Paper Ejection Section .....	A-9
<b>3 Layout of Boards .....</b>	<b>A-10</b>
3.1 MC Unit .....	A-10
3.2 Control Panel .....	A-11
3.3 Switching Power Supply .....	A-11
3.4 PS P.W.B. Unit .....	A-11
<b>4 Overall Schematic Diagram .....</b>	<b>A-13</b>
<b>5 Wiring Diagram .....</b>	<b>A-15</b>

---

# ***Chapter 1***

# ***INTRODUCTION***

---

# 1 FEATURES

### 1. Supports five types of standard folding modes and custom folding mode

Standard folding: Single fold, double fold, irregular accordion fold, letter fold, accordion fold

Custom folding : Two types can be registered as keys.

### 2. Maximum processing speed is 200 sheets/minute (A4, single fold)

Maximum processing speed for 8.5" × 11" (LTR) single fold is 207 sheets/minute.

### 3. Supports wide types of art and coated paper

### 4. Holds large volume of paper

More than 1,000 sheets of paper can be stacked on the paper feed tray.

### 5. Adopts the air suction paper feed method

Stable and high speed paper feed is realized by the adoption of the air suction paper feed method used in the collator system.

### 6. Skew correction

Use of skew rollers (registration rollers) corrects skewing of paper.

### 7. Operability features and additional functions succeeded from DF-920



# 2 SPECIFICATIONS

Specifications and dimensions are subject to change without prior notice for improvements.

## 2.1 Type and Method

Item	Contents
Type	Desktop paper folder
Paper feed method	Belt suction method by fan (Air suction paper feed method)
Folding method	Press roller + folding stopper method
Paper ejection section conveyance method	Stacker roller + flat belt conveyance method

## 2.2 Performance and Functions

### 2.2.1 Processing performance

Item	Contents
Paper feed tray capacity	Maximum stacking height: 100 mm * 1000 sheets (fine quality paper 81.4 g/m <sup>2</sup> ) * 1250 sheets (fine quality paper 64 g/m <sup>2</sup> )
Folding mode	Standard folding (single fold, double fold, irregular accordion fold, letter fold, accordion fold), custom folding
Maximum processing speed	UK model 200 sheets/minute (A4), 140 sheets/minute (A3) * When 81.4 g/m <sup>2</sup> fine quality paper is single folded
	USA model 207 sheets/minute (8.5" × 11") * When 81.4 g/m <sup>2</sup> (20 lb) fine quality paper is single folded
Folding misalignment	[A] : 1.0 mm or less [B] : 0.5 mm or less
Dog-ear	[C] : 1.5 mm or less
W dent	[D] : 0.5 mm or less

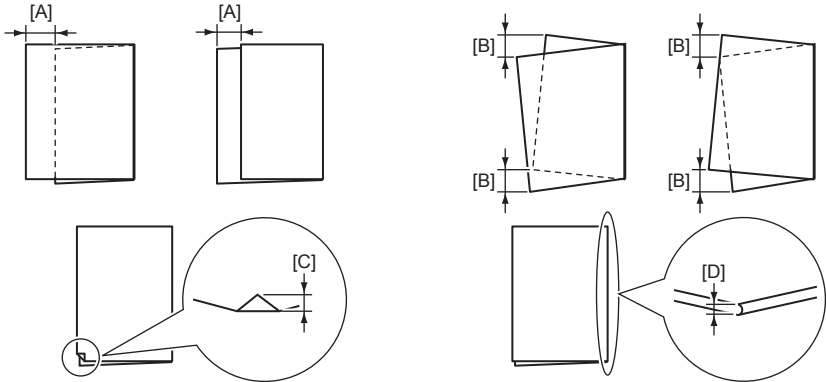

## 2 SPECIFICATIONS

### a. Folding mode condition

\*1: For single fold, art paper or coated paper up to 209.4 g/m<sup>2</sup> can be used.

\*2: Use fine quality paper of 64 g/m<sup>2</sup>, set the processing speed above speed 4, and set the folded plane length of folding plate 2 to more than 47 mm.

<UK model>

Folding mode	Paper size					
	A3	B4	A4	B5	A5	B6
Single fold	○	○	*1	*1	*1	*1
Double fold	○	○	○	○	○	*2
Irregular accordion fold	○	○	○	○	○	○
Letter fold	○	○	○	○	○	○
Accordion fold	○	○	○	○	○	○
Custom fold	Folded paper length within 250 mm					

<USA model>

Folding mode	Paper size				
	11" × 17" (LGR)	8.5" × 14" (LGL)	8.5" × 11" (LTR)	7" × 8.5" (STMT)	5.5" × 8.5" (INV)
Single fold	○	○	*1	*1	*1
Double fold	○	○	○	○	*2
Irregular accordion fold	○	○	○	○	○
Letter fold	○	○	○	○	○
Accordion fold	○	○	○	○	○
Custom fold	Folded paper length within 250 mm				

## 2.2.2 Functions

Item	Contents
Paper size detection	Automatic detection of standard paper sizes (fed by short edge feeding): <UK model> A3, B4, A4, B5, A5, B6 <USA model> 11" × 17" (LGR), 8.5" × 14" (LGL), 8.5" × 11" (LTR), 7" × 8.5" (STMT), 5.5" × 8.5" (INV)
Paper feed tray control	Paper presence detection, automatic rise/descent (manual raising/lowering also possible)
Movement of folding stopper	Automatic setting (Manual setting also possible)
Movement of stacker roller	Automatic setting (Manual setting also possible)
Liquid crystal display (LCD)	Paper size, folding stopper position, operation/error message
Counter	4-digit, selection of add or subtract count method
Other functions	Folding stopper position adjustment registration* <sup>1</sup> Custom folding registration (2 ways)* <sup>1</sup> Non-standard paper length registration* <sup>1</sup> Interval Last time fold Folding stopper fixed Thick paper supported Forced paper ejection Forced paper ejection in folding plate Stacker belt continuous rotation LCD backlight automatic OFF (energy saving function)

\*1: Details of folding stopper position adjustment registration, custom folding registration, and non-standard paper length registration

Item	Range	Remarks
Folding stopper position adjustment registration	-5.0 to +5.0 mm (-0.2 to +0.2 inch)	Minimum adjustment unit: 0.125 mm (0.005 inch) * The display unit on the control panel is 0.01 inch. <b>NOTE</b> ● The folded size by folding plate 2 cannot be corrected for single folding. ● The folded size by folding plate 2 can be corrected between 0 to +5.0 mm for double folding of B6 paper. ● The folded size by folding plate 2 can be corrected between 0 to +5.0 mm for irregular accordion folding of B6 paper. ● If paper length is registered, the correction range may be limited.
Custom folding registration	Folded size by folding plate 1 42 to 325 mm (1.65 to 12.79 inch)	* 0 mm for single folding.
	Folded size by folding plate 2 47 to 217 mm (1.85 to 8.54 inch)	
Non-standard paper length registration	182 to 432 mm (7.2 to 17 inch)	

## 2 SPECIFICATIONS

### 2.3 Paper

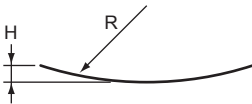
Item	Contents
Paper type	Sheet
Paper size (Width × Length)	Max. : 297 × 432 mm Min. : 120 × 182 mm Standard size <UK model> A3, B4, A4, B5, A5, B6 <USA model> 11" × 17" (LGR), 8.5" × 14" (LGL), 8.5" × 11" (LTR), 7" × 8.5" (STMT), 5.5" × 8.5" (INV)
Paper quality	Fine quality paper, recycled paper, art paper, coated paper
Paper weight	Fine quality paper, recycled paper : 52.3 to 157 g/m <sup>2</sup> Art paper, coated paper : 73.3 to 157 g/m <sup>2</sup> * However, when single folding art paper or coated paper width less than 216 mm, paper up to 209.4 g/m <sup>2</sup> can be used.
Curl amount 	The upper and lower curl amount should be above 130 mm in radius (R), the curl height (H) should be less than 5 mm, without corrugation. <b>NOTE</b> When using paper curled more than the above, correct the curl.

## 2.4 Others

### 2.4.1 Power supply/dimensions/mass (weight)

Item	Contents
Operating environment (Storage environment)	5 to 35°C, 20 to 80% RH (-10 to +50°C, 10 to 90% RH) * However no condensation
Power supply	USA model: AC 120 V ± 10% 60 Hz ± 10% UK model : AC 220 to 240 V ± 10% 50/60 Hz ± 10%
Current consumption	Max. : 2 to 1 A (140 W) Standby mode : 14 W
Acoustic noise	Max. : 88 dB (A) <b>Measuring method</b> Machine installation conditions ; Install the unit on a desk of 600 mm in height. Paper feed conditions ; B4, fine quality paper, 64 g/m <sup>2</sup> , double folding, maximum processing speed Sound collection microphone position when measuring acoustic pressure level ; Sound is collected at 1.0 m from measured surface, 1.5 m height, indoor below 30 dB, scale A, and FAST operation characteristics.
Dimensions (W × D × H)	In use : 1,277 × 534 × 590 mm (50.28" × 21.02" × 23.23") In storage : 912 × 534 × 590 mm (35.91" × 21.02" × 23.23")
Mass (Weight)	71 kg (156.5 lb)

### 2.4.2 Error detection functions

Item	Contents
Paper feed error detection function	Mis-feed, continuous-feed, paper jam
Other detection functions	Opening/closing of top cover L/R and side cover With/without folding plate Paper feed tray UP/DOWN error Safety lever ON/OFF

# 3 NAMES OF PARTS

## 3.1 External Parts

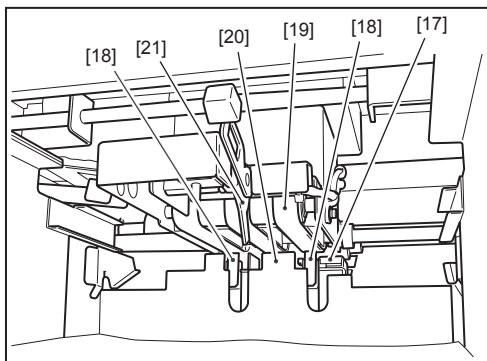
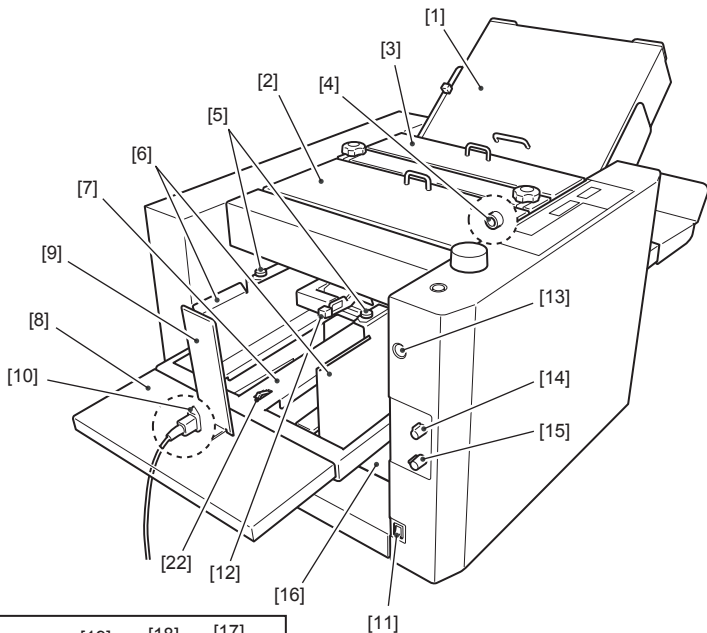

- [1] Folding plate
- [2] Top cover L
- [3] Top cover R
- [4] Skew correction knob
- [5] Side guide adjusting knob
- [6] Side guide
- [7] Paper feed tray
- [8] Auxiliary paper feed tray
- [9] Rear guide
- [10] Power cord inlet
- [11] Power switch
- [12] Level sensor adjusting lever
- [13] Tray down button
- [14] Separating air adjusting knob
- [15] Separator adjusting knob
- [16] Safety lever
- [17] Separating-air duct
- [18] Separator
- [19] Suction belt
- [20] Shutter
- [21] Level sensor
- [22] Paper switch (USA model only)

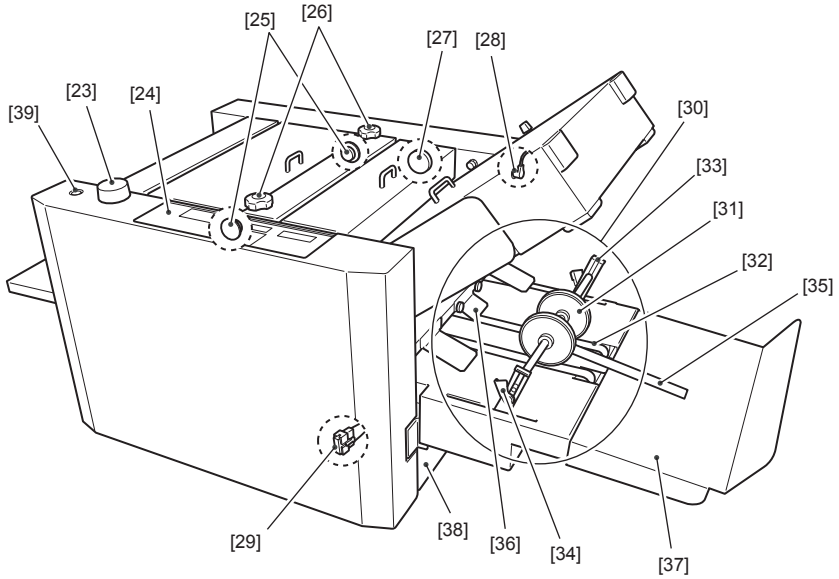

- [23] Side guide dial
- [24] Control panel
- [25] Skew roller spring pressure adjusting knob
- [26] Skew roller fixing knob
- [27] Jam correction knob
- [28] Folding plate connector
- [29] Stacker unit connector
- [30] Stacker unit
- [31] Stacker roller
- [32] Stacker belt

- [33] Stacker support
- [34] Lever
- [35] Auxiliary paper ejection guide
- [36] Paper ejection guide
- [37] Paper receiving tray
- [38] Side cover
- [39] Thin paper feed button

## 4 CONTROL PANEL

### 4.1 Control Panel

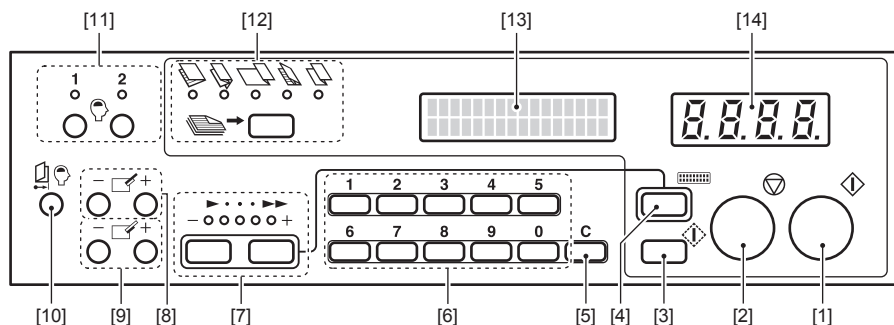

No.	Name	Operation
[1]	Start key	Press to start paper folding.
[2]	Stop key	Press to stop paper folding.
[3]	Test key	Press to test fold two sheets of paper.
[4]	Mode key	Press to switch the function setting mode.
[5]	Clear key	Press to clear the value entered with the numerical keys.
[6]	Numerical keys (0 to 9)	Press to enter the number of sheets to be processed or paper length.
[7]	Speed key/Speed lamp	<p>Press to select the processing speed from five levels (Speed 1 to 5). Every time the [+] key is pressed, the speed increases. Every time the [-] key is pressed, the speed decreases.</p> <ul style="list-style-type: none"> <li>○ Speed 5' With the speed 5 lamp lit, press and hold the [+] key for more than three seconds, and the lamp will stop lighting and start blinking. Set this when paper jamming occurs frequently with thick paper.</li> <li>○ Speed 1' With the speed 1 lamp lit, press and hold the [-] key for more than three seconds, and the lamp will stop lighting and start blinking. Set this when paper feed error occurs frequently with recycled paper.</li> </ul>
[8]	Folding plate 1 folding stopper adjusting key	Press to adjust the position (folding position) of the folding stopper of folding plate 1.
[9]	Folding plate 2 folding stopper adjusting key	Press to adjust the position (folding position) of the folding stopper of folding plate 2.
[10]	Adjustment registration key	If the position of the folding stopper has been finely adjusted in standard folding operations, the adjustment value can be registered with this key.
[11]	Custom folding registration key/ Custom folding registration lamp	Press to register the position of the folding stopper and stacker roller which have been moved when using custom folding modes. When this lamp is lit, it means that the custom folding mode is registered.
[12]	Folding mode key/ Standard folding lamp	Press to select the folding mode from five standard folding modes. When a folding mode registered with the folding stopper position adjustment value is selected, the corresponding lamp blinks.
[13]	Liquid crystal display (LCD)	Displays the size of standard paper stacked on the paper feed tray, paper length registered, and error messages.
[14]	Numerical display (Counter)	When using the add count mode, displays the number of sheets processed. When using the subtract count mode, displays the number of sheets left to be processed.



## 4.2 User Menu (Function Setting Mode)

This section summarizes the information provided in the instruction manual.

For details, refer to the instruction manual.

The "\*" in the "Setting (2nd line display)" column indicates setting at shipment.

Selection of function : [Mode] key  
 Selection of setting : [Speed] key (+/-)  
 Input of values : Numerical keys  
 Confirmation of settings : [Stop] key

Function (1st line display)	Setting (2nd line display)	Contents/Remarks
Length	OFF* 182 to 432 mm	Set and register the paper length when standard folding non-standard paper.  <b>NOTE</b> <ul style="list-style-type: none"> <li>● To insure the quality of the fold when paper width is 120 mm, it is recommend not to exceed 240 mm in length.</li> <li>● The paper length data registered is erased when the power is turned off. To save the registered data, set the operation mode to the last time fold mode.</li> </ul>
MODE	NORMAL* LAST TIME FOLD STOPPER FIXED	Setting for shortening the operation procedure.  <b>Normal mode</b> There is a need to perform various settings in each use. The unit will perform initialization operations when the power is turned ON.  <b>Last time fold mode</b> Function which starts the unit at the settings used the last time when the power is turned ON. When set to this mode, the following will be set automatically at power ON. <ul style="list-style-type: none"> <li>● Folding mode</li> <li>● Stacker roller position</li> <li>● Processing speed</li> </ul> <b>Folding stopper fixed mode</b> When set to this mode, the following settings will be fixed. Therefore initial settings of the unit will be omitted when the power is turned ON, enabling folding to be started immediately. <ul style="list-style-type: none"> <li>● Folding stopper position</li> <li>● Stacker roller position</li> <li>● Processing speed</li> </ul>
SET INTERVAL	OFF* 3 SEC 5 SEC 10 SEC	Setting this setting to ON repeatedly pauses operations for every specified number of sheets and restarts operations after several seconds.  <b>NOTE</b> The setting is erased when the power is turned OFF.
AIR POWER	NORMAL* LIGHT	Function for adjusting the air amount for separating paper.

## 4 CONTROL PANEL

Function (1st line display)	Setting (2nd line display)	Contents/Remarks
<b>FEED SPEED</b>	<b>FAST</b> <b>NORMAL*</b> <b>SLOW</b>	Function for changing the processing speed when single folding, double folding, or letter folding standard paper.
<b>QUANTITY</b>	<b>HIGH*</b> <b>NORMAL</b> <b>LOW</b>	Function which changes the amount of paper stacked on the paper feed tray.  <b>Reference</b> The number of sheets stacked for each setting is as follows for fine quality paper 81.4 g/m <sup>2</sup> or equivalent. <ul style="list-style-type: none"> <li>● HIGH : 1000 sheets</li> <li>● NORMAL : 600 sheets</li> <li>● LOW : 300 sheets</li> </ul>
<b>STACKER BELT</b>	<b>NORMAL*</b> <b>CONTINUOUS</b>	Function for changing the operation mode of the stacker belt.  <b>NORMAL</b> The stacker belt operates according to the paper ejection timing.  <b>CONTINUOUS</b> The stacker belt operates continuously.
<b>THICK PAPER</b>	<b>NOT CORRECTED*</b> <b>CORRECTED</b>	The correction value of the folding stopper positions can be changed for thick paper.

## 5 USER ADJUSTMENTS

### 5.1 List of Adjustments

Adjustment contents	Remarks
Skew correction (Correction of folding misalignment along sides of paper)	☞ Refer to “5.2.1 Skew correction by side guide adjusting knob”.
	Correction method when paper trimming misalignment occurs. ☞ Refer to “5.2.2 Skew correction by skew correction knob”.
	Correction method when folding misalignment is inconsistent, and this is thought to be caused by paper thickness. ☞ Refer to “5.2.3 Using the skew roller spring pressure adjusting knob”.
Folding position correction (Correction of folding misalignment along vertical length of paper)	☞ Refer to “5.3.1 Folding position correction by folding mode”.
Change of stacker roller position	Adjustment method when paper alignment on the paper receiving tray is poor. ☞ Refer to “5.4.1 Changing the stacker roller position”.
Change of stacker roller height	Adjustment method when paper jams frequently at the stacker roller in the use of thick paper, etc. ☞ Refer to “5.4.2 Changing the stacker roller height”.

### 5.2 Paper Feed Adjustments

#### 5.2.1 Skew correction by side guide adjusting knob

Before correcting, check that the skew roller spring pressure adjusting knobs are set at the same position for the left and right sides. If their positions differ, folding misalignment may occur.

☞ Refer to “5.2.3 Using the skew roller spring pressure adjusting knob”.

- Loosen the side guide adjusting knobs [1].
- Move the side guides [2] by hand according to the folding misalignment direction.  
Refer to the position of the adjusting knob needle [A] for the adjusting amount.

#### NOTE

Always move the left and right side guides in the same direction.

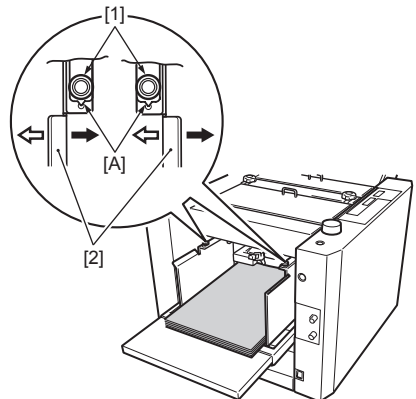

- Tighten the side guide adjusting knobs and secure the side guides.
- Perform test folding and check that the folding misalignment has improved.

	Folding misalignment A	Folding misalignment B
Moving direction of side guide	←	→
Example of adjusting knob needle position		

## 5 USER ADJUSTMENTS

### 5.2.2 Skew correction by skew correction knob

Perform this skew correction if folding misalignment occurs due to trimming misalignment of the paper.

- 1) Loosen the skew roller fixing knobs [1].
- 2) Open the top cover L [2].

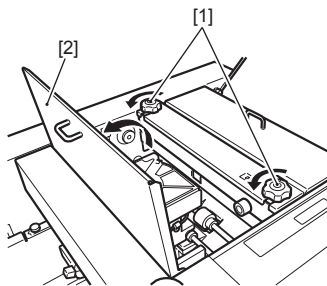

- 3) Rotate the skew correction knob [3] according to the folding misalignment direction. Refer to the position of the check window needle [A] shown in the figure for the adjusting amount.

	Folding misalignment C	Folding misalignment D
Rotating direction of knob		
Example of check window needle position		

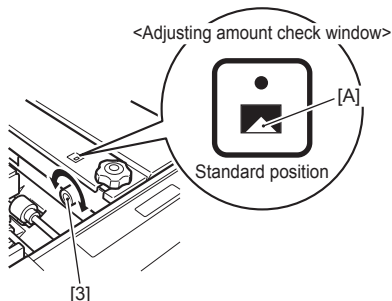

- 4) Close the top cover L.
- 5) Tighten the skew roller fixing knobs.
- 6) Perform test folding and check that the folding misalignment has improved.

### 5.2.3 Using the skew roller spring pressure adjusting knob

Switch the knob position if paper passage appears unstable; such as the folding misalignment amount differs with each folded paper.

- 1) Open the top cover L.
- 2) Switch the position of the adjusting knob according to the paper thickness.  
 Top position [A] : Above 127.9 g/m<sup>2</sup>  
 Bottom position [B] : Less than 127.9 g/m<sup>2</sup>

#### NOTE

Be sure to set the left and right knobs at the same position.

- 3) Close the top cover L.

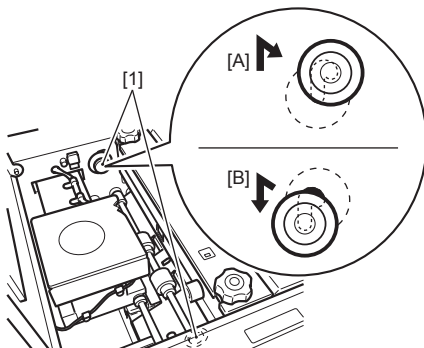



## 5.3 Folding Position Adjustments

### 5.3.1 Folding position correction by folding mode

Correct folding misalignment using the folding stopper adjusting keys of folding plates 1 and 2 referring to the following table.

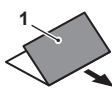
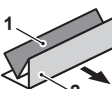
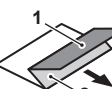
The correction range of standard folding is within  $\pm 5$  mm (to folding misalignment of 10 mm).

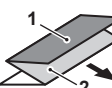
Folding mode	State of folded plane	Correction method
Single fold 	Folded plane 1 is long.	Press the [-] key of the folding plate 1 folding stopper adjusting key.
	Folded plane 1 is short.	Press the [+] key of the folding plate 1 folding stopper adjusting key.
	* There is no folded plane 2 in the case of single folding. (Folding plate 2 is not used.)	
Double fold*1 	Folded plane 1 is long.	Press the [-] key of the folding plate 1 folding stopper adjusting key.
	Folded plane 1 is short.	Press the [+] key of the folding plate 1 folding stopper adjusting key.
	Folded plane 2 is long.	Press the [-] key of the folding plate 2 folding stopper adjusting key.
	Folded plane 2 is short.	Press the [+] key of the folding plate 2 folding stopper adjusting key.
Irregular accordion fold*1 	Folded plane 1 is long.	Press the [+] key of the folding plate 1 folding stopper adjusting key.
	Folded plane 1 is short.	Press the [-] key of the folding plate 1 folding stopper adjusting key.
	Folded plane 2 is long.	Press the [-] key of the folding plate 2 folding stopper adjusting key.
	Folded plane 2 is short.	Press the [+] key of the folding plate 2 folding stopper adjusting key.
Letter fold 	Folded plane 1 is long.	Press the [-] key of the folding plate 1 folding stopper adjusting key.
	Folded plane 1 is short.	Press the [+] key of the folding plate 1 folding stopper adjusting key.
	Folded plane 2 is long.	Press the [-] key of the folding plate 2 folding stopper adjusting key.
	Folded plane 2 is short.	Press the [+] key of the folding plate 2 folding stopper adjusting key.
Accordion fold 	Folded plane 1 is long.	Press the [+] key of the folding plate 1 folding stopper adjusting key.
	Folded plane 1 is short.	Press the [-] key of the folding plate 1 folding stopper adjusting key.
	Folded plane 2 is long.	Press the [-] key of the folding plate 2 folding stopper adjusting key.
	Folded plane 2 is short.	Press the [+] key of the folding plate 2 folding stopper adjusting key.

## 5 USER ADJUSTMENTS

### \*1: Correction range restrictions

For double fold and irregular accordion fold, the correction range may be restricted and cannot be corrected for some paper lengths.

Restricted folded plane	Paper length [mm] (Inch)	Correction range restrictions
Folded plane 2 for double fold	182 to 187 (7.2" to 7.4")	Correction using the [-] key is not possible.
	188 to 207 (7.5" to 8.1")	The values which can be corrected vary in the -0.1 to -4.8 mm (-0.004" to -0.19") range according to the paper length.
	208 to 432 (8.2" to 17.0")	No restriction
Folded plane 1 for irregular accordion fold	182 to 426 (7.2" to 16.7")	No restriction
	427 to 432 (16.8" to 17.0")	The values which can be corrected vary in the +0.6 to +4.3 mm (+0.02" to +0.17") range according to the paper length.
Folded plane 2 for irregular accordion fold	182 to 189 (7.2" to 7.4")	Correction using the [-] key is not possible.
	190 to 208 (7.5" to 8.2")	The values which can be corrected vary in the -0.2 to -4.7 mm (-0.008" to -0.19") range according to the paper length.
	209 to 432 (8.3" to 17.0")	No restriction

## 5.4 Paper Ejection Adjustments

### 5.4.1 Changing the stacker roller position

The position of the stacker roller is automatically set according to the folded paper length in standard folding.

In the case of custom folding, if alignment of paper ejected to the paper receiving tray is poor, change the stacker roller position.

#### Reference

When standard folding non-standard paper, the stacker roller will automatically be set according to the folded paper length (calculated from folding mode and paper length).

- 1) While pressing the [stop] key, press a numerical key between 1 and 7.

Changing the folding mode returns the position to the default setting.

#### Default setting of stacker roller position (Standard paper size)

The numbers in the table are numerical key numbers.

Folding mode	UK model						USA model				
	A3	B4	A4	B5	A5	B6	11" × 17" (LGR)	8.5" × 14" (LGL)	8.5" × 11" (LTR)	7" × 8.5" (STMT)	5.5" × 8.5" (INV)
Single fold	6	6	4	4	3	3	6	6	5	3	2
Double fold	3	3	2	3	3	2	2	2	2	1	2
Irregular accordion fold	6	3	3	2	2	3	5	5	4	2	2
Letter fold	5	2	3	3	3	2	5	4	2	2	2
Accordion fold	5	3	3	4	3	2	5	4	1	2	2
Custom fold	*1										

\*1: Set in the range of "4 to 6" according to the folding stopper position, however there is a need to check the folded paper length and adjust accordingly. (Refer to the following table.)

#### Reference for stacker roller position (Custom folding)

Numerical key setting	Contents	Numerical key setting	Folded paper length	
			mm	Inch
0	Pressing the [0] key while pressing the [stop] key returns the position to the default setting.	2	To 80	To 3.15"
		3	81 to 110	3.16" to 4.33"
		4	111 to 140	4.34" to 5.51"
1	Use the [1] key if paper jams at the [2] position.	5	141 to 170	5.52" to 6.69"
		6	171 to 210	6.70" to 8.27"
		7	211 to 250	8.28" to 9.84"

## 5 USER ADJUSTMENTS

---

### 5.4.2 Changing the stacker roller height

If paper jams frequently at the stacker roller in the use of thick paper, change the height of the stacker roller.

- 1) Lift up the stacker roller [1].
- 2) Turn down the lever [2] of the stacker support in the arrow direction.

**NOTE**

After completing folding operations, be sure to return the stacker roller to the original position.

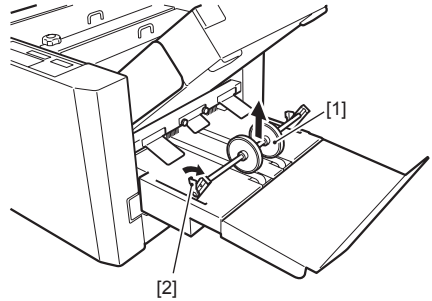



## 6 USER MAINTENANCE

### 6.1 List of Maintenance Items

Part	Maintenance	Frequency	Remarks
Lower paper sensor (PS8)	Cleaning	Once a week	Paper dusts, etc. adhered near the sensor may cause misdetection. ☞ Refer to "6.2.1 Cleaning the sensors".
Paper feed inlet sensor (PS10)	Cleaning	Once a week	
Paper ejection outlet upper sensor (PS12)	Cleaning	Once a week	
Paper ejection outlet lower sensor (PS12)	Cleaning	Once a week	
Suction belt	Cleaning	Once a week	If dirty, folding misalignment and paper feed problems can occur. ☞ Refer to "6.2.2 Cleaning the suction belts".
Folding roller	Cleaning	Once a week	If dirty, folding misalignment and folding problems can occur. ☞ Refer to "6.2.3 Cleaning the folding rollers".
Stacker belt	Cleaning	Once a week	If dirty, paper ejection problems such as poor paper alignment, etc. can occur. ☞ Refer to "6.2.4 Cleaning the stacker belts".

### 6.2 Cleaning by User

#### NOTE

Prior to cleaning, be sure to turn off the power switch and disconnect the power cord plug from the outlet.

After cleaning, make sure that the areas that were cleaned are completely dry before connecting the power cord.

## ⚠ WARNING



**Do not use flammable sprays inside or near the unit (e.g. when cleaning the unit).**

Such flammable gas may ignite and cause a fire or combustion.

Take precautions against fire and ensure ventilation when using alcohol, and store the alcohol in a safe place after use. Also note that use of other solvents can damage the rubber rollers and resin inside the unit, resulting in malfunctions.

#### 6.2.1 Cleaning the sensors

##### a. Lower paper sensor (PS8)

- 1) Clean the protection film [1] of the paper sensor (PS8) under the paper feed tray with a dry and soft cloth.

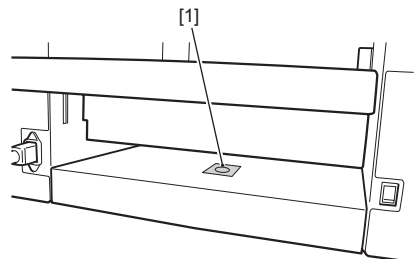

## 6 USER MAINTENANCE

---

### b. Paper feed inlet sensor (PS10)

- 1) Open the top cover L.
- 2) Insert the nozzle of the dust removal spray (canned air) into the cut-away on the sensor cover vertically, and blow air.
- 3) Close the top cover L.

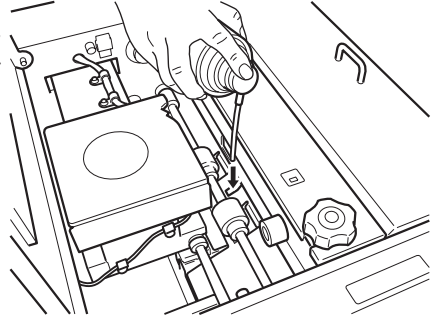

### c. Paper ejection outlet upper sensor (PS12)

- 1) Remove the folding plate and open the top cover R.
- 2) Insert the nozzle of the dust removal spray (canned air) into the cut-away on the sensor cover, and blow air.
- 3) Return the folding plate to its original position.
- 4) Close the top cover R.

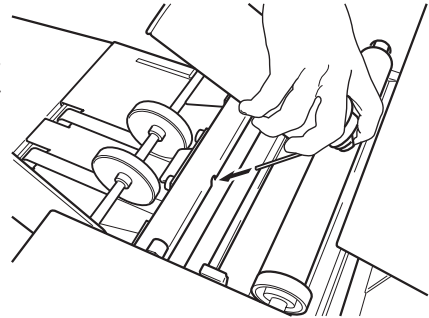

### d. Paper ejection outlet lower sensor (PS12)

- 1) Loosen the two knob screws and remove the paper ejection guide (Center).
- 2) Insert the nozzle of the dust removal spray (canned air) into the cut-away on the sensor cover, and blow air.
- 3) Reinstall the paper ejection guide to its original position.

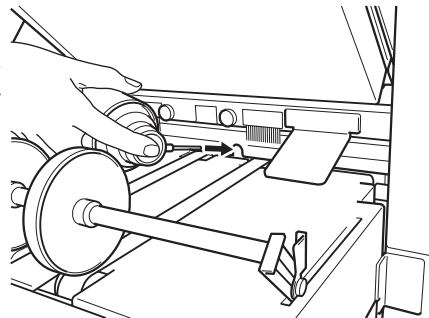

### 6.2.2 Cleaning the suction belts

- 1) Move the side guides out to the sides and lower the paper feed tray.
- 2) Turn off the power switch and disconnect the power cord plug from the outlet.
- 3) Open the top cover L [1].
- 4) Rotate the suction belts [3] by rotating the paper feed shaft [2] by hand. Clean them with a cloth moistened with alcohol.
- 5) Close the top cover L.

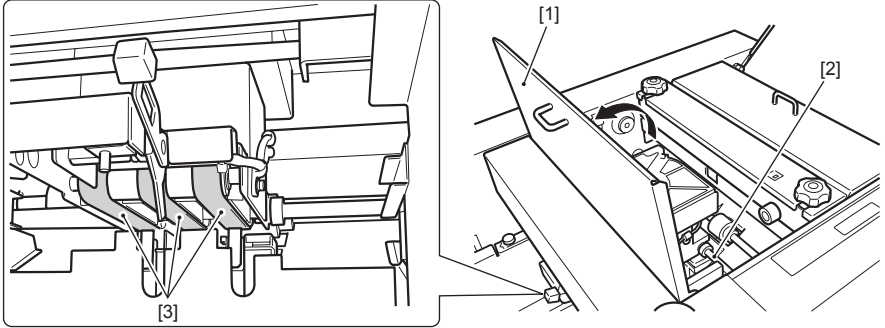

### 6.2.3 Cleaning the folding rollers

- 1) Remove the folding plate.
- 2) Open the top cover R [1].
- 3) While rotating the folding rollers with the jam correction knob [2], clean them with a cloth moistened with alcohol.
- 4) Return the folding plate to its original position.
- 5) Check that the jam correction knob rotates smoothly.

#### NOTE

If the folding plate is not secured at the correct position, the knob will not only feel heavy, but the folding rollers and folding plate may get damaged.

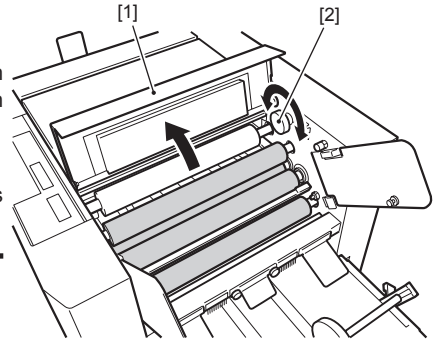

- 6) Close the top cover R.

### 6.2.4 Cleaning the stacker belts

- 1) Lift up the stacker roller [1], and turn down the lever [2] of the stacker support in the arrow direction.
- 2) While rotating the stacker belts [3] by hand, clean them with a cloth moistened with alcohol.
- 3) Return the stacker roller to its original position.

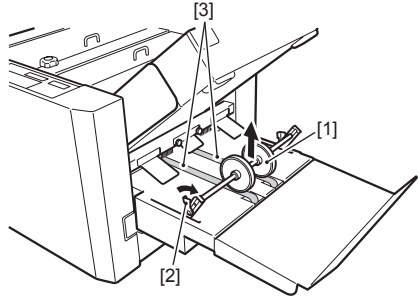

### 6.3 Replacement by User

In normal use (excluding malfunctions), there are no parts requiring replacement by the user to maintain product performance and work quality.

---

# *Chapter 2*

# **OPERATIONS**

---

# 1 OUTLINE

## 1.1 Function Configuration

The functions of this unit can broadly be divided into the paper feed section, folding section, and paper ejection section.

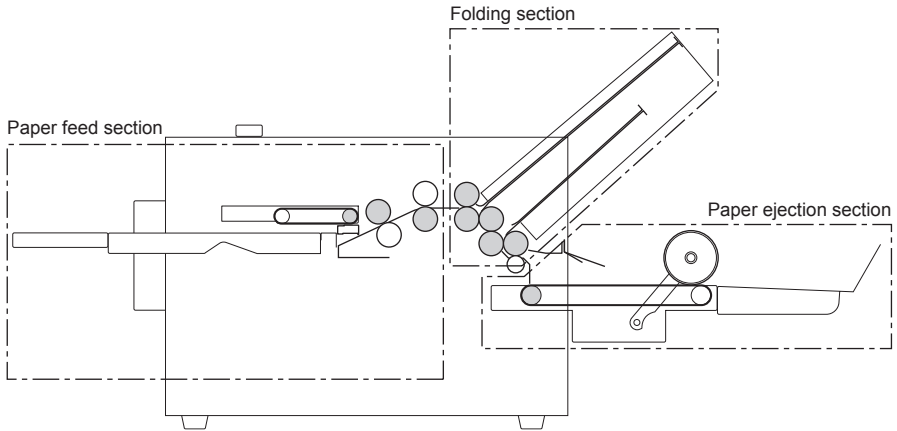

## 1.2 Block Diagram of Structure

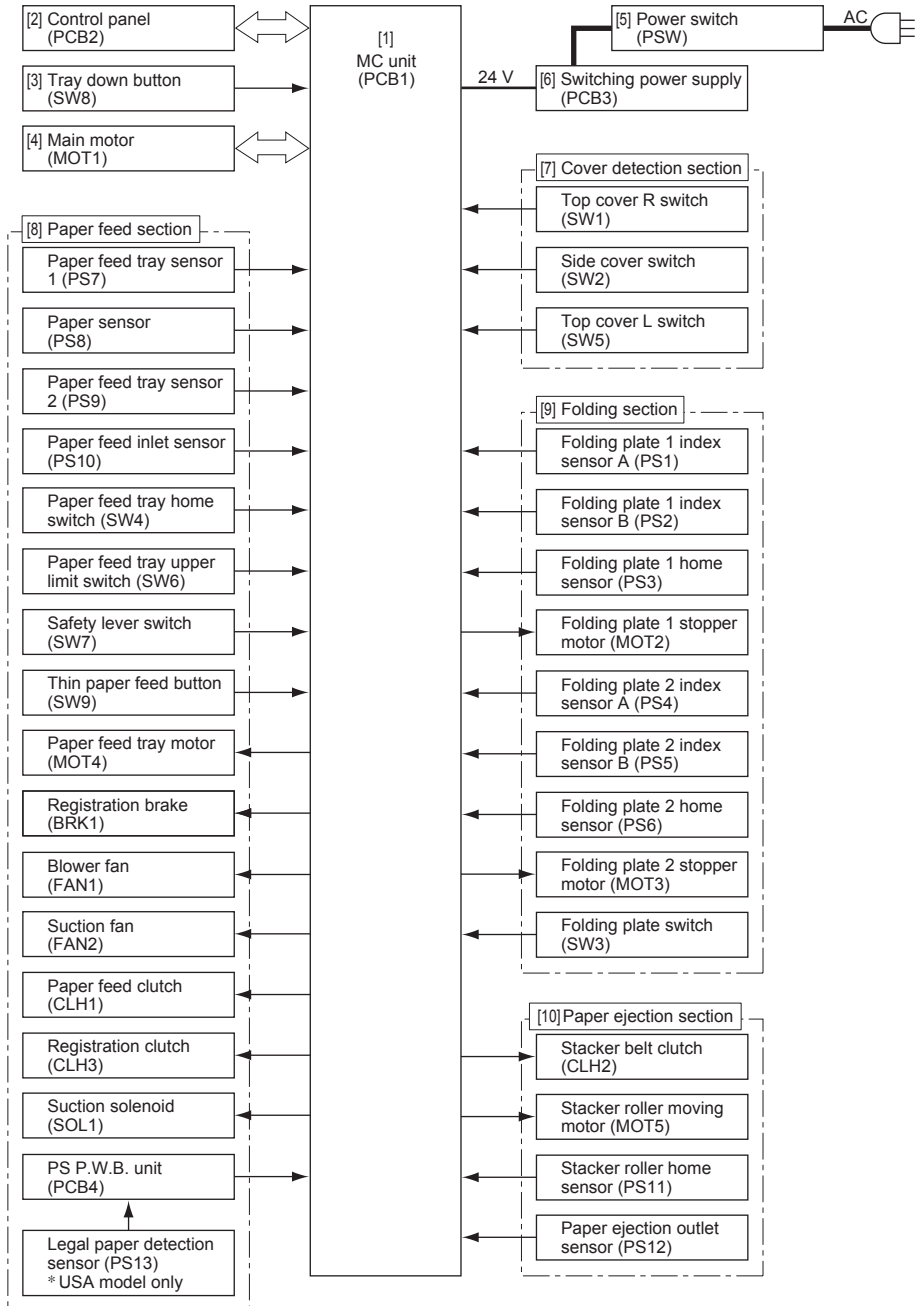

## 1 OUTLINE

---

### [1] MC unit (PCB1)

Incorporates a 32-bit microprocessor for controlling the overall operations of this unit.  
The following are main functions.

#### a. Overall control

Incorporates a 32-bit microprocessor for controlling the overall operations of this unit (paper feed, folding, paper ejection).

The control program is written in the microprocessor.

#### b. 12 V, 6.5 V, 5 V generation

Stepped down from the 24 V input power supply.

5 V is used as the power supply for the input system and board circuits.

12 V and 6.5 V are used as the power for board circuits.

#### c. Memory backup

Incorporates one EEPROM (U1) to backup the various settings when the power switch is OFF.

#### d. Version up

Upgrades the control program version.

\* The separate 128K-byte (1M-bit) EPROM is required.

☞ Refer to "Chapter 6 MAINTENANCE MODE > 4 UPGRADING THE PROGRAM VERSION".

### [2] Control panel (PCB2)

Performs various settings such as processing speed, number of sheets processed, etc.

Composed of the LCD, 7-segment window, LED, and push switches.

### [3] Tray down button (SW8)

<DC 24 V, push switch>

The paper feed tray descends while this button is pressed.

### [4] Main motor (MOT1)

☞ Refer to "2.2 Main Motor Control".

### [5] Power switch (PSW)

For turning ON/OFF the AC input to the switching power supply (PCB3).

### [6] Switching power supply (PCB3)

<Input: AC 100 V, output: DC 24 V, overcurrent/overvoltage protection circuit incorporated>

Used for generating DC 24 V.

If the protection circuit operates due to some reason, the DC output will go OFF.

To recover from this state, turn OFF the power switch, wait for more than three minutes, and turn ON the power switch.



[7] Cover detection section

☞ Refer to “2 EXTERNAL COVER/CONTROL SECTION”.

[8] Paper feed section

☞ Refer to “3 PAPER FEED SECTION”.

[9] Folding section

☞ Refer to “4 FOLDING SECTION”.

[10] Paper ejection section

☞ Refer to “5 PAPER EJECTION SECTION”.

### 1.3 Basic Operations

#### 1.3.1 Operations at power ON

- 1) Power switch ON
- 2) Reading of memory data
- 3) Initialization of each part
  - Detection of folding plate 1 folding stopper home position
  - Detection of folding plate 2 folding stopper home position
  - Detection of stacker roller home position
  - Detection of paper on paper feed tray
  - Detection of paper feed position of paper feed tray
- 4) Standby status

#### 1.3.2 Operations at power OFF

This unit does not perform processing such as memory backup, etc. when the power switch is OFF.

When the power switch is turned OFF, AC supply to the switching power is cut off immediately.

#### 1.3.3 Operation during processing

- 1) Press the [start] key or [test] key.

##### Implementation of settings

- 2) The MC unit calculates the targeted set position of each part based on the following conditions.
  - Paper size
  - Folding mode
  - Correction value
- 3) The MC unit compares the targeted set position of each part and the current stopping position, and moves the parts as required.
  - Movement of folding plate 1 folding stopper
  - Movement of folding plate 2 folding stopper
  - Movement of stacker roller
  - Paper feed preparations  
(After paper detection, the blower fan (FAN1) and suction fan (FAN2) are turned ON, and the unit stands by for about two seconds.)

##### Folding operations

- 4) Paper feed
  - 5) After paper is folded using the folding plate and folding roller, paper is ejected onto the stacker unit.
-  Refer to "4.1.2 Folding operations".

### 1.3.4 Stopping operations when problems occur

The stopping operations of this unit differ according to the error detection and key operations.

#### a. Normal stopping of unit

Operations stop after paper in the unit is ejected.

The unit will set into the normal stopping state in the following cases.

- When the [stop] key is pressed
- When "NO PAPER" is displayed
- When "JAM FEED SECT" (continuous paper feed is detected) is displayed  
When single folding, double folding, or letter folding standard paper at processing speed 5, as the paper feed interval is short, the unit will stop immediately.
- When paper size error (length of paper fed is shorter than setting) occurs

#### **Automatic paper ejection**

If paper causing paper size error is not ejected but remains in the unit, this unit will perform initialization of the folding stopper, as well as rotate the folding roller and stacker belt at low speed to eject the paper automatically.

#### b. Immediate stopping of unit

The unit will stop immediately. Paper currently being processed will all be jammed.

The unit will set into the immediate stopping state in the following cases.

- After detecting continuous paper feed, if the paper feed inlet sensor (PS10) continues to detect paper even after a certain period of time
- When internal paper jam is detected  
Automatic paper ejection is carried out when paper size error is also detected at the same time.
- When paper ejection section paper jam is detected  
The paper ejection outlet sensor (PS12) does not turn OFF even after a certain period of time.
- When the top cover L, top cover R, or side cover is open
- When folding plate set errors, paper feed tray UP errors, paper feed tray DOWN errors, motor problems of each part are detected

## 2 EXTERNAL COVER/CONTROL SECTION

### 2.1 Power Supply

#### 2.1.1 Outline

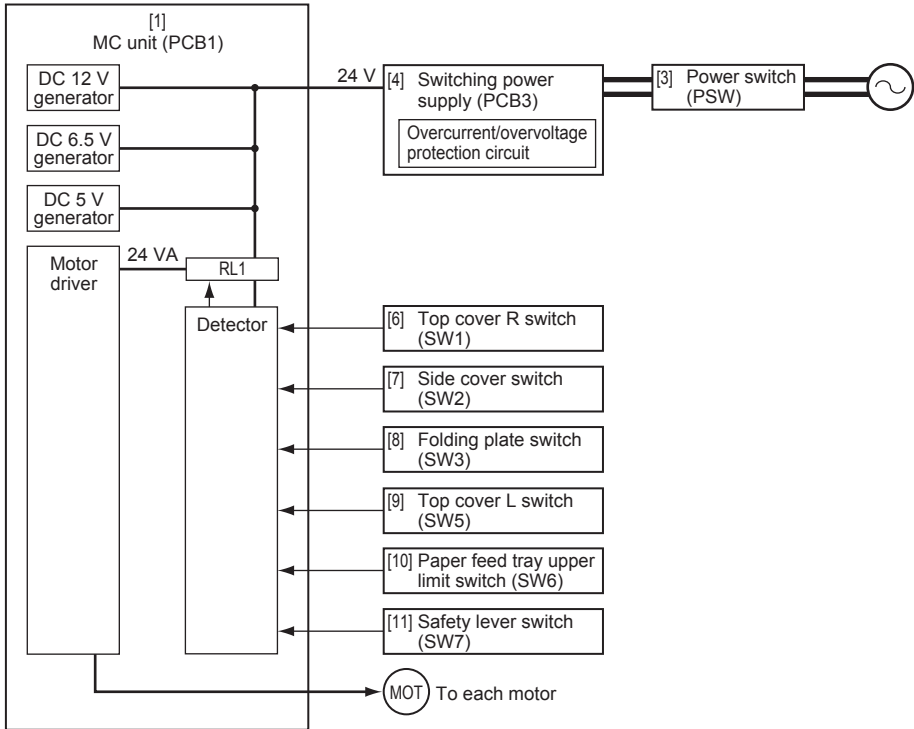

#### 2.1.2 Safety function

##### a. Configuration

[6] Top cover R switch (SW1)

<DC 24 V, microswitch>

Detects the open/close of the top cover R.

**“TOP COVER-R OPEN”;**

When the top cover R is detected as open, this message appears on the control panel.

[7] Side cover switch (SW2)

<DC 24 V, microswitch>

Detects the open/close of the side cover.

**“SIDE COVER OPEN”;**

When the side cover is detected as open, this message appears on the control panel.

[8] Folding plate switch (SW3)

<DC 24 V, microswitch>

Detects the presence of the folding plate.

**“F.PLATE SET ERROR”;**

When the folding plate cannot be detected, this message appears on the control panel.

[9] Top cover L switch (SW5)

<DC 24 V, microswitch>

Detects the open/close of the top cover L.

**“TOP COVER-L OPEN”;**

When the top cover L is detected as open, this message appears on the control panel.

[10] Paper feed tray upper limit switch (SW6)

<DC 24 V, microswitch>

Detects the upper limit position of the paper feed tray.

**“TRAY UP ERROR”;**

When the upper limit position of the paper feed tray is detected, this message appears on the control panel.

[11] Safety lever switch (SW7)

<DC 24 V, microswitch>

Detects the ON/OFF of the safety lever.

**“TRAY DOWN ERROR”;**

When the safety lever turns ON, this message appears on the control panel.

### b. Operations

- 1) One of the following switches activate; SW1, SW2, SW3, SW5, or SW6.
- 2) The interlock relay (RL1) on the MC unit goes OFF.
- 3) The 24 VA supplied to the motor driver from RL1 goes OFF.
- 4) All motors (MOT1 to 4) stop.

## 2.2 Main Motor Control

### 2.2.1 Outline

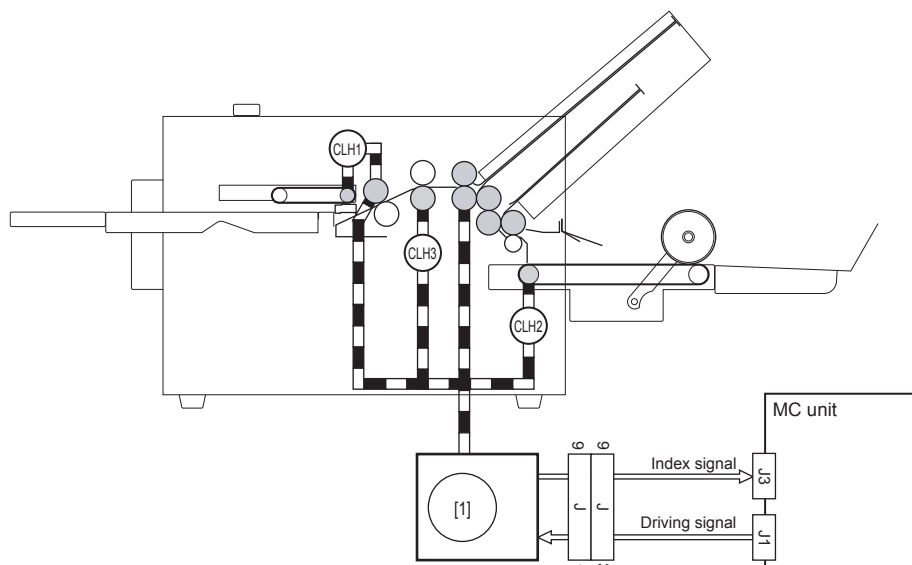

[1] Main motor (MOT1)

<Input: DC 24 V, output: 60 W, brushless motor>

During processing, this motor rotates constantly to drive each part.

### 2.2.2 Operations

The processing speed of this unit is controlled by varying the rotational speed of the main motor based on the control signal from the MC unit.

The processing speed can be switched in five steps using the speed key on the control panel.

#### Reference (Actual value measured)

Condition: When 64 g/m<sup>2</sup> fine quality paper is single folded

Speed key setting	Processing speed (sheets/minute)			
	A4	A3	8.5" × 11" (LTR)	11" × 17" (LGR)
5 (Fast)	200	140	207	174
4	128	106	130	115
3	98	82	100	88
2	72	60	75	66
1 (Slow)	44	38	45	40

## 2.3 Counter

### 2.3.1 Outline

This unit does not have an electromagnetic counter.

Total counting for maintenance is performed on the program and recorded in the EEPROM (U1) on the MC unit.

The total count recorded in the EEPROM (U1) can be checked in the maintenance mode.

☞ Refer to “Chapter 6 MAINTENANCE MODE > 3.1 Menu List”.

### 2.3.2 Operations

The total count increases when the paper feed inlet sensor (PS10) detects the trail edge of the paper.

#### Reference

The following is carried out for paper jams occurring after the paper feed inlet sensor (PS10) detects the trail edge of the paper.

- Internal jam;  
The total count becomes “-1” at the point of detection.
- Paper ejection section jam;  
The total count remains “+1” even if jam is detected.

## 3 PAPER FEED SECTION

### 3.1 Outline

#### 3.1.1 Configuration

The functions of the paper feed section can broadly be divided into the paper feed tray section, suction conveyance section, and registration section.

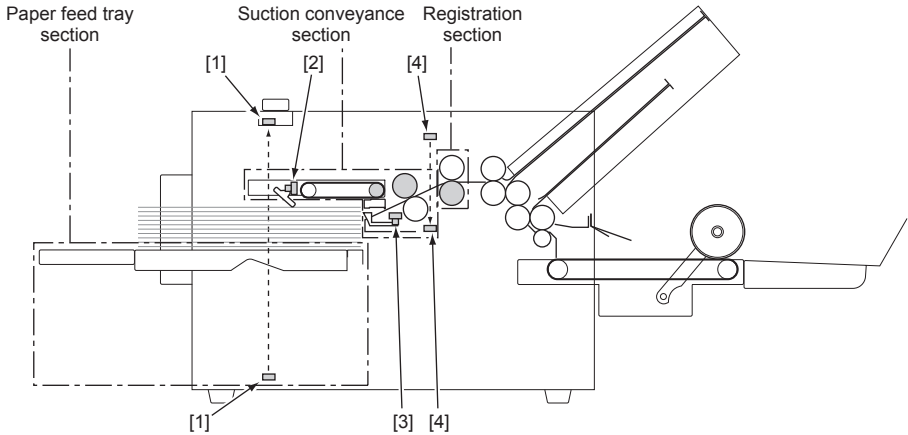

- [1] Paper sensor (PS8)  
<DC 5 V, photosensor (light-emitting and receiving separation type)>  
Detects the presence of paper on the paper feed tray.
- [2] Paper feed tray sensor 1 (PS7)  
<DC 5 V, photosensor>  
Detects whether paper is at the paper feedable position.
- [3] Paper feed tray sensor 2 (PS9)  
<DC 5 V, photosensor>  
Detects paper feed tray height.
- [4] Paper feed inlet sensor (PS10)  
<DC 5 V, photosensor (light-emitting and receiving separation type)>  
Detects paper feed state.



### **3.1.2 Paper feed operations**

#### **Paper feed tray setting operations**

- 1) Pressing the [start] key or [test] key raises the paper feed tray until the paper feed tray sensor 2 (PS9) detects paper.
- 2) When the paper feed tray sensor 2 (PS9) detects paper, the blower fan (FAN1) and suction fan (FAN2) turn ON. The unit stands by for two seconds in this state and then separates paper with the air from the blower fan (FAN1).
- 3) The paper feed tray sensor 1 (PS7) detects the topmost paper lifted up by air. If it fails to detect, the paper feed tray will rise until this paper is detected.
- 4) After some time from the detection of paper by the paper feed tray sensor 1 (PS7), paper feed starts.

#### **Paper feed operations**

- 5) After completion of paper feed tray setting operations, the suction solenoid (SOL1) turns ON and sucks the topmost paper lifted up by air to the suction belt.
- 6) After a certain period of time, the paper feed clutch (CLH1) turns ON and paper is fed. If the second sheet of paper is fed together with the topmost paper, the second sheet is dropped by the separator.
- 7) If paper is fed continuously, when the paper feed inlet sensor (PS10) detects the trail edge of the paper, feeding of the next paper starts.

#### **Reference**

In the following processing conditions, paper feed interval is controlled to enhance processing speed.

- Standard paper
- Processing speed 5 or 5'
- Single fold, double fold, letter fold

 Refer to "3.3.4 Conveyance section > c. Paper feed interval control".

#### **Skew correction**

- 8) Paper is conveyed to the registration section by the conveyance roller, and hits the stationary registration roller (skew correction).
- 9) The registration roller rotates (registration brake OFF, registration clutch ON), and paper is conveyed to the folding roller.

## 3.2 Paper Feed Tray Section

### 3.2.1 Outline

The functions of the paper feed tray section can broadly be divided into the side guide section and tray up/down section.

#### 1. Side guide section

Aligns the width of paper stacked on the paper feed tray and also detects paper size.

#### 2. Tray up/down section

Rises and descends to the paper feed position according to the volume of paper on the paper feed tray.

### 3.2.2 Side guide section

#### a. Configuration

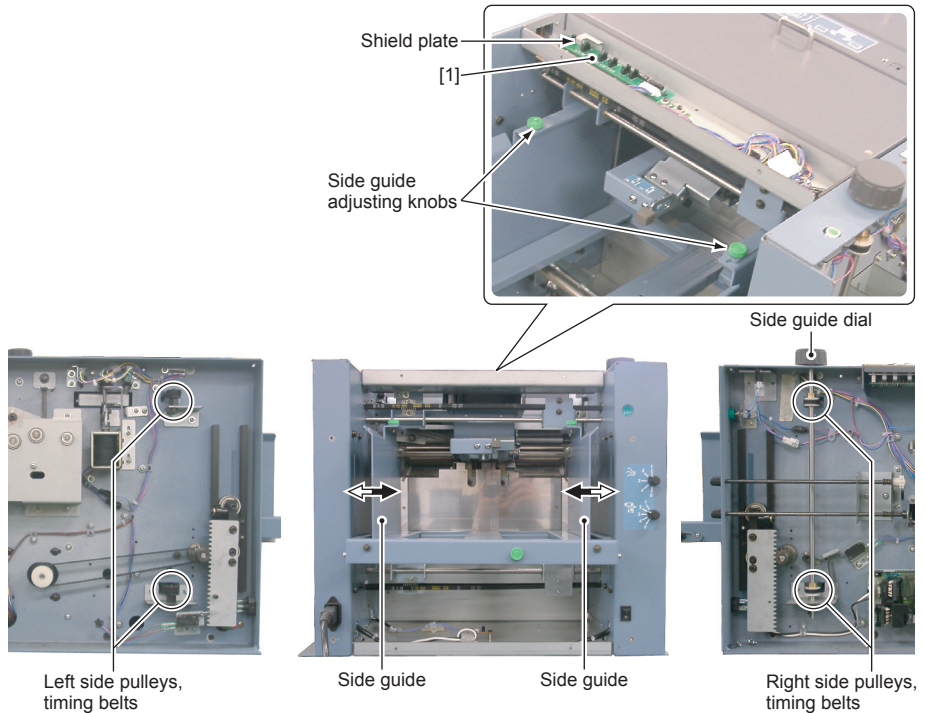

[1] PS P.W.B. unit (PCB4)  
Detects paper width.  
Composed of photosensors.

**b. Movement of side guide**

Rotating the side guide dial moves the side guide via the pulley and timing belt on the dial shaft.

**c. Paper size detection**

The side guide L bracket is mounted with a shield plate which also moves along the paper width when the side guide L moves. When this shield plate blocks the sensor on the PS P.W.B. unit, this unit detects that paper of the width corresponding to the sensor is stacked on the tray.

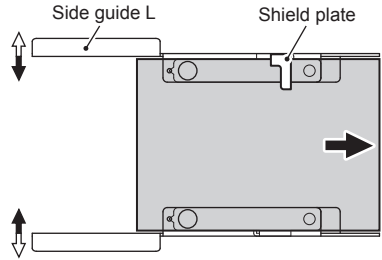

**NOTE**

Paper length is not detected.  
 Paper size is detected if paper is stacked in the short edge feeding direction.

**d. Side guide correction**

Loosening the side guide adjusting knob enables fine adjustment of the fixing position of the side guide and skew correction of paper on the paper feed tray.

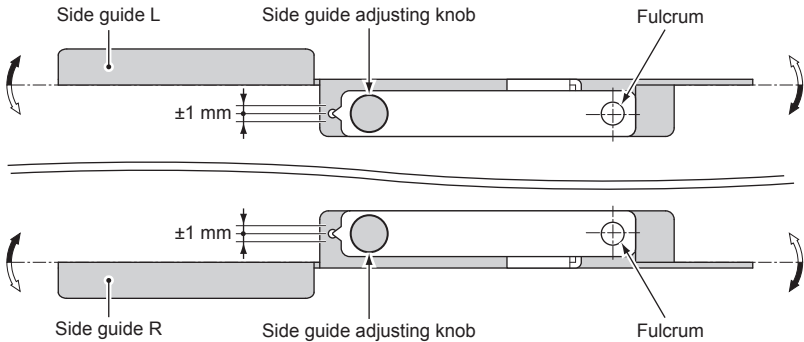

#### 3.2.3 Tray up/down section

##### a. Configuration

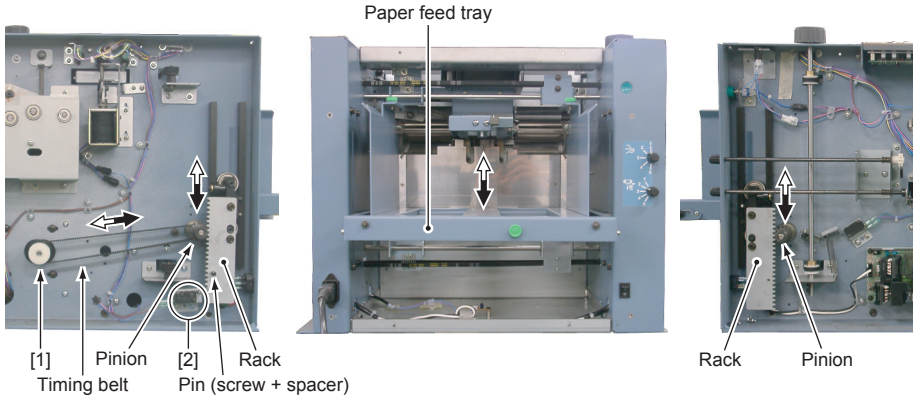

[1] Paper feed tray motor (MOT4)

<DC 24 V, DC motor>

Raises and lowers the paper feed tray.

[2] Paper feed tray home switch (SW4)

<DC 24 V, microswitch>

Detects the home position of the paper feed tray.

##### b. Rise/descent of paper feed tray

The paper feed tray is raised and lowered by the paper feed tray motor (MOT4).

This motor raises and lowers the paper feed tray via the timing belt, pinion, and rack.

The rising position of the paper feed tray is detected by the paper feed tray sensor 1 (PS7) and paper feed tray sensor 2 (PS9).

☞ Refer to “3.1.2 Paper feed operations”.

The home position of the paper feed tray is detected when the pin (screw + spacer) attached on the rack at the frame B side turns OFF the paper feed tray home switch (SW4).

## 3.3 Suction Conveyance Section

### 3.3.1 Outline

The functions of the suction conveyance section can broadly be divided into the suction section, separator section, and conveyance section.

#### 1. Separator section

Blows air on paper stacked on the paper feed tray to separate paper.

#### 2. Suction section

Suctions paper stacked on the paper feed tray to the suction belt and feeds paper inside.

#### 3. Conveyance section

Conveys paper fed into the unit.

### 3.3.2 Separator section

#### a. Configuration

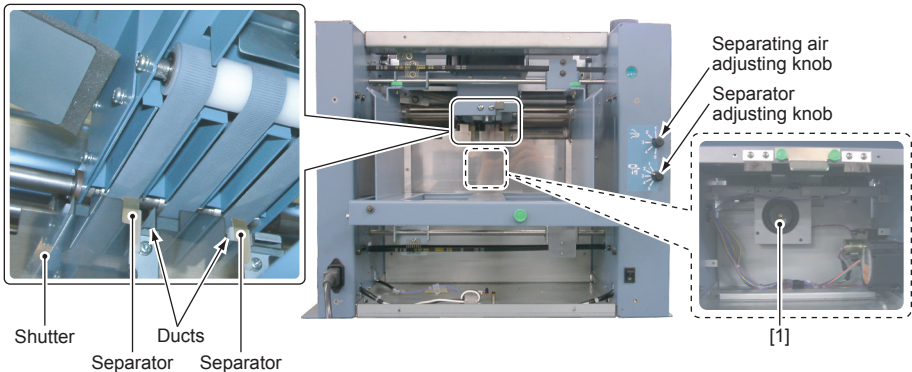

[1] Blower fan (FAN1)

<DC 24 V, fan motor>

Supplies air for paper separation.

#### b. Paper separation by air

When the blower fan (FAN1) rotates, air is blown out of the duct to separate paper on the paper feed tray.

Rotating the separating air adjusting knob slides the shutter and changes the duct opening amount.

##### **When the duct opening amount is large;**

The separating air is strong.

##### **When the duct opening amount is small;**

The separating air is weak.

#### c. Separator

When several sheets of paper are being fed by the suction belt, the separator drops the second sheet of paper onwards.

Rotating the separator adjusting knob moves the separator up and down.

#### **NOTE**

Adjust the separator height according to the paper thickness and type.

#### 3.3.3 Suction section

##### a. Configuration

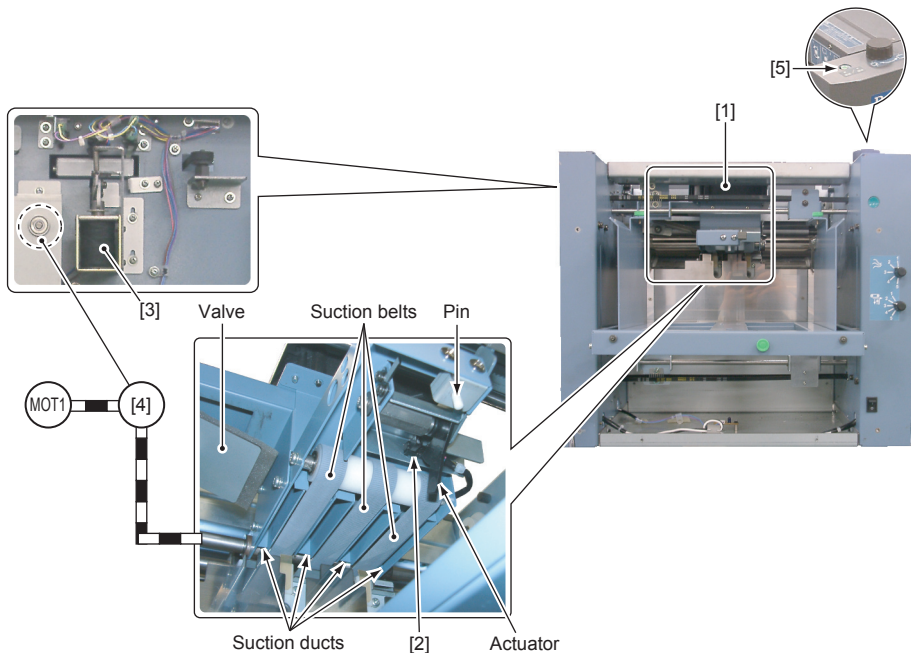

[1] Suction fan (FAN2)

<DC 24 V, fan motor>

Suction source for suctioning paper. Controls the suction of paper on the paper feed tray together with the suction solenoid (SOL1).

[2] Paper feed tray sensor 1 (PS7)

☞ Refer to “3.1 Outline”.

[3] Suction solenoid (SOL1)

<DC 24 V, solenoid>

Opens/closes the suction duct valve.

[4] Paper feed clutch (CLH1)

<DC 24 V, electromagnetic clutch>

Transmits the drive of the main motor to the suction belt via the conveyance roller.

[5] Thin paper feed button (SW9)

<DC 5 V, push switch with built-in LED>

Turns ON/OFF the operations of the suction solenoid (SOL1).

#### **b. Paper suction**

When the valve is closed while the suction fan (FAN2) is rotating, air is suctioned in from the suction duct, and paper is suctioned to the suction belt.

The valve is opened/closed by the solenoid (SOL1).

Normally, the valve is open and controlled to close only when the paper feed clutch (CLH1) is ON.

The pin (white rod) works to stabilize the movements of paper (especially thin paper) suctioned to the suction belt.

#### **Suctioned state (When solenoid valve is closed);**

The air suctioned in from the suction duct becomes strong.

#### **Open state (When solenoid valve is open);**

The air suctioned in from the suction duct becomes weak.

#### **c. Thin paper control**

When fine quality paper less than 81.9 g/m<sup>2</sup> is used, press the thin paper feed button (SW9) to process as thin paper.

When this button is pressed, paper will be fed with the suction solenoid (SOL1) in the OFF state (valve open state).

#### 3.3.4 Conveyance section

##### a. Configuration

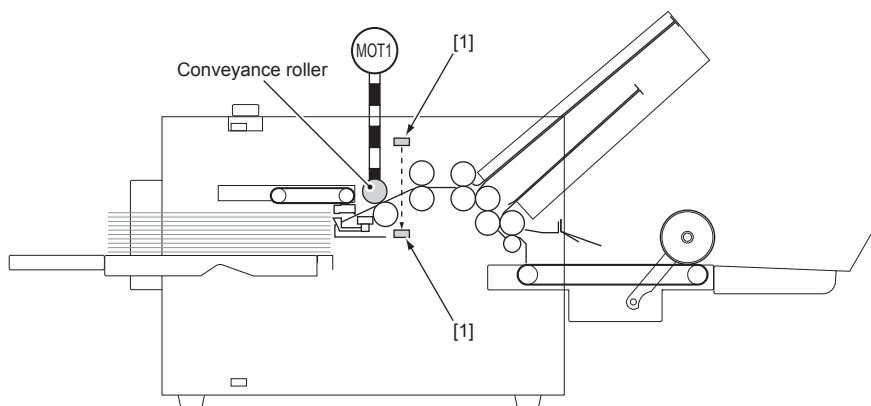

[1] Paper feed inlet sensor (PS10)

☞ Refer to “3.1 Outline”.

##### b. Paper conveyance

The conveyance roller is rotated by the drive of the main motor (MOT1).

Paper fed into the unit by the suction section is conveyed to the registration section by the conveyance roller.

##### c. Paper feed interval control

During continuous paper feed, feed operations of the following paper start after the paper feed inlet sensor (PS10) has detected the paper trail edge.

However, in the case of the following processing conditions, to enhance processing speed, the next paper feed operations are started after a certain period of time has passed from the detection of the paper lead edge by the paper feed inlet sensor (PS10).

- Standard paper
- Processing speed 5 or 5'
- Single fold, double fold, letter fold

The relation between the “paper feed interval setting” of the user menu (function setting mode) and paper feed interval control is as follows.

Paper feed interval setting	Paper feed interval control		Remarks
	Processing speed	Paper feed start time	
FAST	5'	A (Quick)	The paper feed start time A to D differs according to the size of standard paper.
	5	B	
NORMAL	5'	C	
	5		
SLOW	5'	D (Slow)	
	5		



## 3.4 Registration Section

### 3.4.1 Outline

The following shows the structure of the registration section.

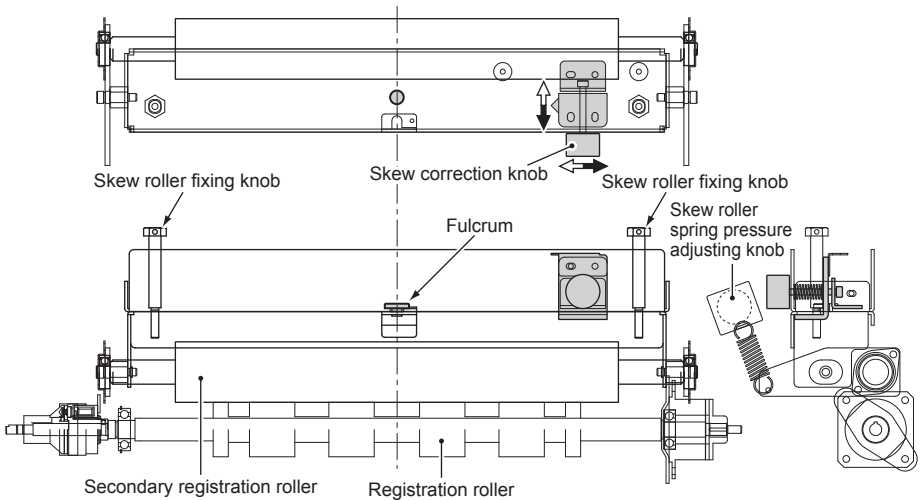

### 3.4.2 Registration control (Skew correction)

#### a. Outline

Skew is corrected by touching the lead edge of paper fed against the registration roller to slack the paper slightly.

The registration roller conveys skew-corrected paper to the folding section.

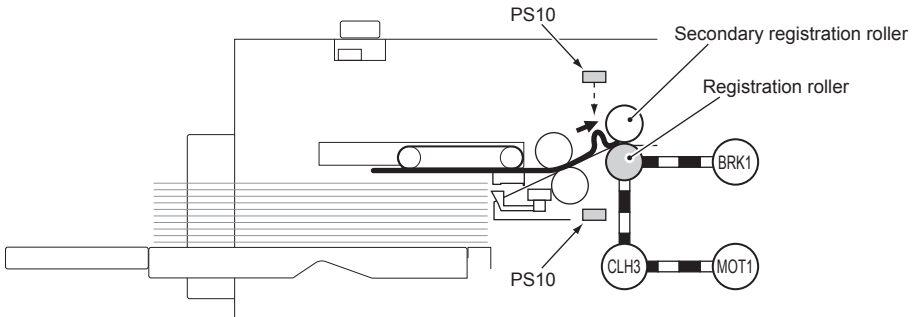

#### NOTE

Adjust the tilt of the secondary registration roller using the skew correction knob as necessary.

☞ Refer to "Chapter 1 INTRODUCTION > 5.2.2 Skew correction by skew correction knob".

### **3 PAPER FEED SECTION**

---

#### **b. Operations**

##### **1st sheet**

- 1) When the paper feed inlet sensor (PS10) detects the paper lead edge, the MC unit starts the pulse count of the main motor (MOT1).
- 2) The paper lead edge touches the registration roller and the paper slacks.
- 3) When the pulse count becomes constant, the registration clutch (CLH3) turns ON to rotate the registration roller.
- 4) The skew of the paper is corrected by the rebounding force generated by the slack and the paper is pulled into the registration roller.
- 5) When the paper lead edge reaches the folding roller section, the registration clutch (CLH3) goes OFF, and the registration roller idles.
- 6) The paper is pulled into the folding section by the folding roller.
- 7) The registration brake (BRK1) turns ON after a certain period of time has passed from the detection of the paper trail edge by the paper feed inlet sensor (PS10), and the registration roller stops rotating.

##### **2nd sheet onwards**

- 8) When the paper feed inlet sensor (PS10) detects the paper lead edge, the registration brake (BRK1) goes OFF.
- 9) Hereafter, steps 2) to 7) are repeated.
- 10) After processing the set number of sheets, the main motor (MOT1) stops and at the same time, the registration brake (BRK1) goes OFF.

## 4 FOLDING SECTION

### 4.1 Outline

#### 4.1.1 Configuration

The functions of the folding section can broadly be divided into the folding plate section and folding roller section.

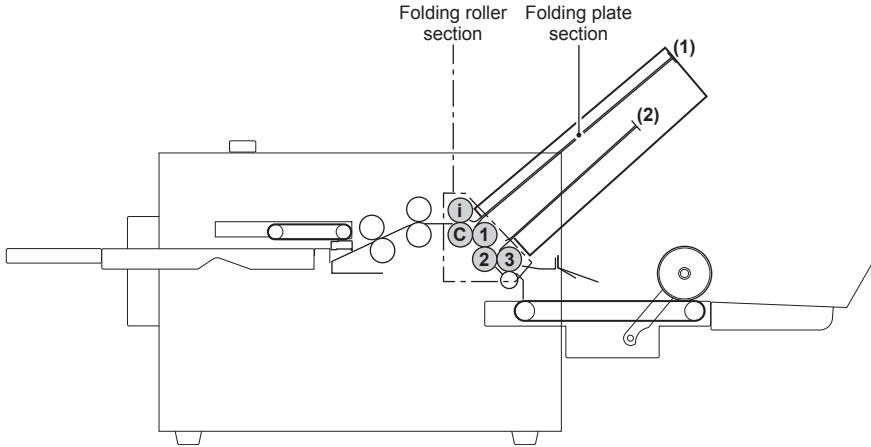

Symbol	Part name	Symbol	Part name
(1)	Folding plate 1	1	Folding roller 1
(2)	Folding plate 2	2	Folding roller 2
i	Idler roller	3	Folding roller 3
C	Center press roller		

#### 4.1.2 Folding operations

##### a. Outline

##### First folding

- 1) Paper conveyed from the registration roller is conveyed by the idler roller and center press roller, and touches the folding stopper of folding plate 1.
- 2) The paper is continuously fed touching the folding stopper of folding plate 1 and slacks.
- 3) The slackened part of the paper is sandwiched between the center press roller and folding roller 1. (First folding)

##### Second folding

- 4) The paper is conveyed by the center press roller and folding roller 1, and touches the folding stopper of folding plate 2. (For single fold, paper is conveyed to the paper ejection section by folding rollers 2 and 3.)
- 5) The paper is continuously fed touching the folding stopper of folding plate 2 and slacks.
- 6) The slackened part of the paper is sandwiched between folding roller 2 and folding roller 3. (Second folding)

##### Paper ejection

- 7) Paper is conveyed to the paper ejection section by folding rollers 2 and 3.

# 4 FOLDING SECTION

## b. Single fold

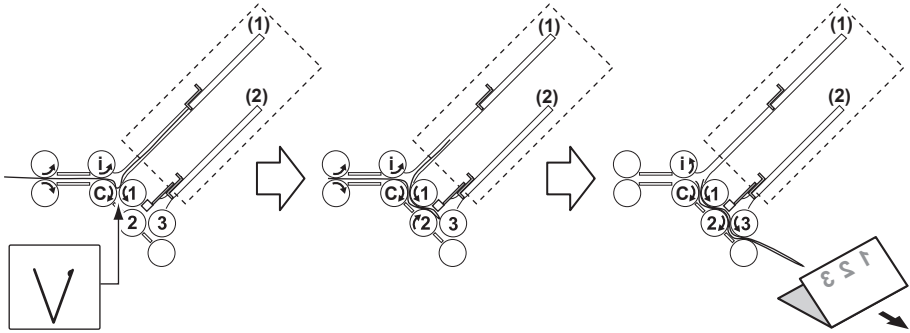

## c. Double fold

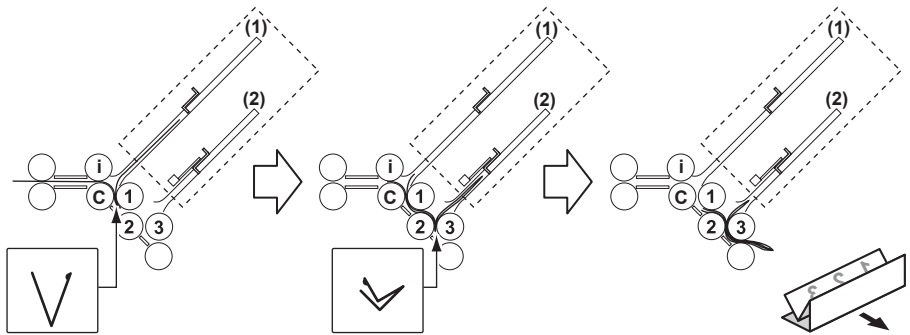

## d. Irregular accordion fold

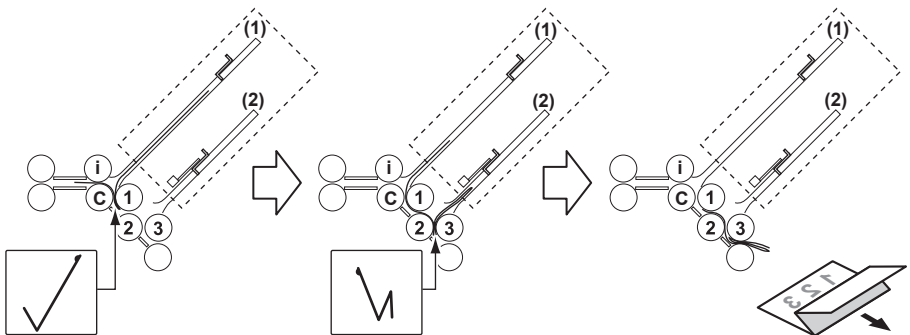

e. Letter fold

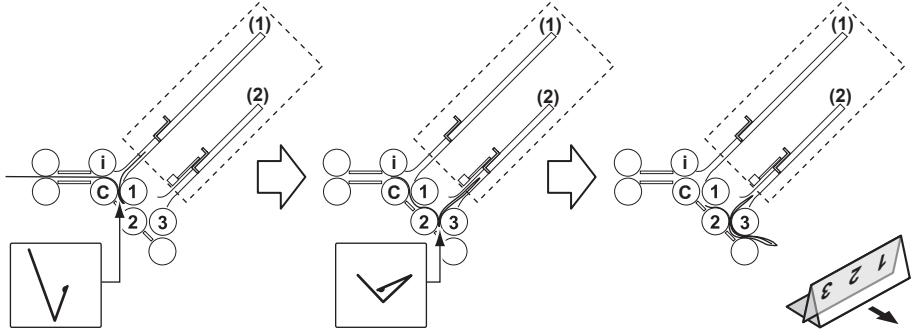

f. Accordion fold

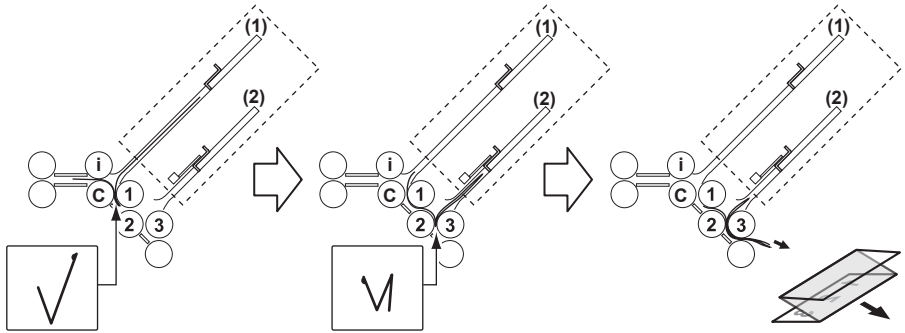

### 4.2 Folding Plate Section

#### 4.2.1 Outline

The functions of the folding plate section can broadly be divided into the folding plate 1 folding stopper section and folding plate 2 folding stopper section.

#### Reference

The basic structure is the same as DF-920/915.

#### 1. Folding plate 1 folding stopper section

Performs the first folding position control.

#### 2. Folding plate 2 folding stopper section

Performs the second folding position control.

#### 4.2.2 Folding stopper sections of folding plates 1 and 2

##### a. Configuration

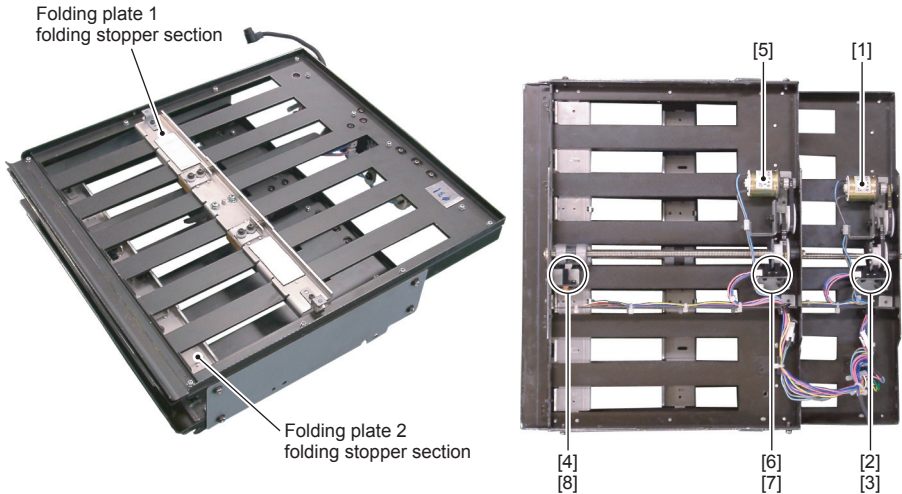

[1] Folding plate 1 stopper motor (MOT2)

[5] Folding plate 2 stopper motor (MOT3)

<DC 24 V, DC motor>

Moves the folding stopper.

[2] Folding plate 1 index sensor A (PS1)

[3] Folding plate 1 index sensor B (PS2)

[6] Folding plate 2 index sensor A (PS4)

[7] Folding plate 2 index sensor B (PS5)

<DC 5 V, photosensor>

Detects the index plate attached to the folding plate stopper motor and the distance moved by the folding stopper.

[4] Folding plate 1 home sensor (PS3)

[8] Folding plate 2 home sensor (PS6)

<DC 5 V, photosensor>

Detects the home position of the folding stopper.

**b. Movement control of folding stopper**

A slit plate (index plate) divided into 12 parts (pulses) is mounted to a screw shaft with a pitch of 1.5 mm. The number of slits (pulses) is counted by two photointerrupters (index sensors) to control the moving distance and direction of the folding stopper.

The minimum distance moved by the stopper is 0.125 mm of one pulse of the above index plate.

**c. Maximum moving distance of folding stopper**

Folding plate 1: 288.5 mm from home position

Folding plate 2: 180.5 mm from home position

**d. Length of folded plane**

	Max.	Min.
Folding plate 1:	325 mm	42 mm
Folding plate 2:	217 mm	47 mm

**e. Adjusting the home position of the folding stopper**

The home position of the folding stopper is the basic position where the shield plate blocks the home sensor added with the correction value set in the following maintenance mode.

- Code No.1 : Correction value of folding plate 1 home position
- Code No.2 : Correction value of folding plate 2 home position
- Code No.3 : Correction value of switching shaft home position

 Refer to “Chapter 6 MAINTENANCE MODE > 3 MENUS AND FUNCTIONS”.

### 4.3 Folding Roller Section

#### 4.3.1 Configuration

**Reference**

The basic structure is the same as DF-920/915.

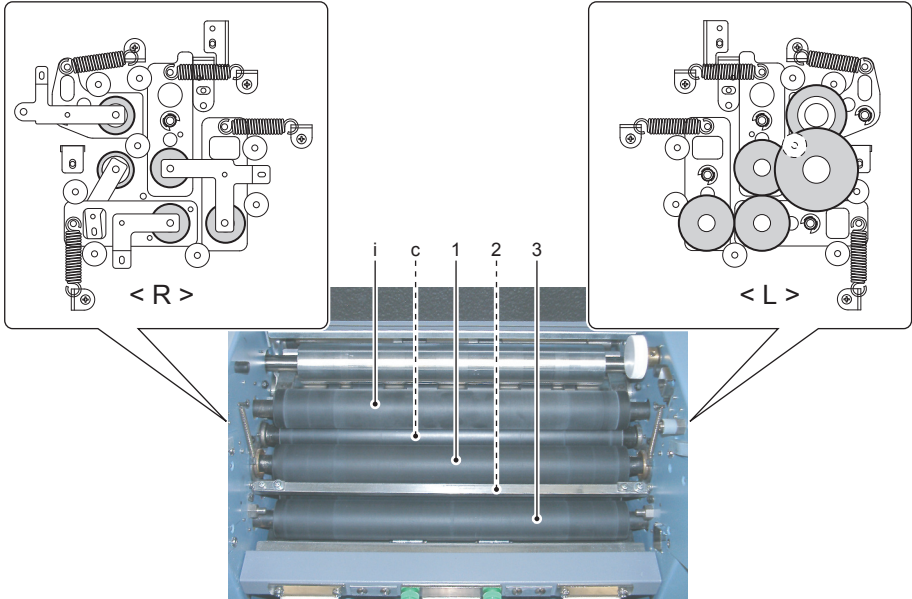

Symbol	Part name	Symbol	Part name
i	Idler roller	1	Folding roller 1
C	Center press roller	2	Folding roller 2
		3	Folding roller 3



## 5 PAPER EJECTION SECTION

### 5.1 Outline

#### 5.1.1 Configuration

The functions of the paper ejection section can broadly be divided into the stacker belt section and stacker roller section.

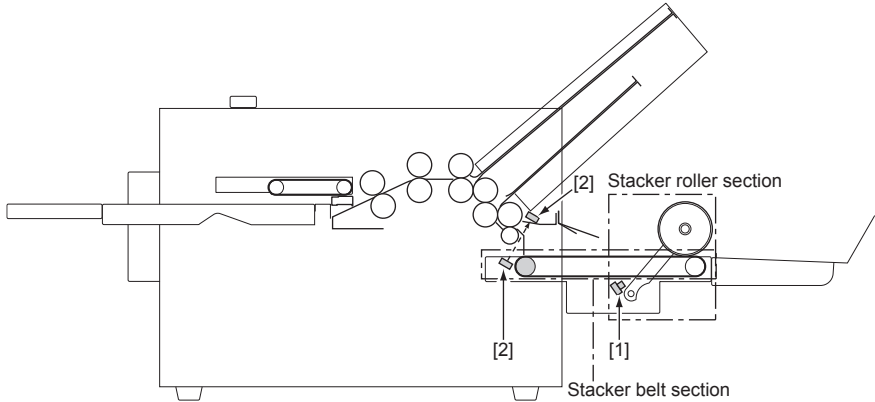

[1] Stacker roller home sensor (PS11)

☞ Refer to “5.3.2 Lever unit drive”.

[2] Paper ejection outlet sensor (PS12)

<DC 5 V, photosensor (light-emitting and receiving separation type)>

Detects paper ejection.

#### 5.1.2 Paper ejection operations

- 1) Folded paper is ejected by folding roller 3 and ejection roller.
- 2) Ejected paper is conveyed to the paper receiving tray by the stacker roller and stacker belt.

## 5.2 Stacker Belt Section

### 5.2.1 Configuration

#### Reference

The basic structure is the same as DF-920/915.

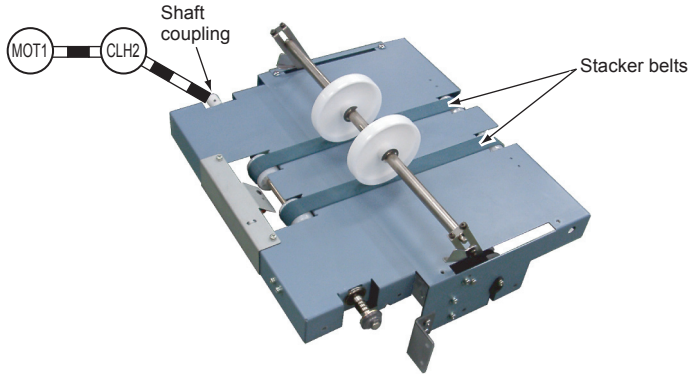

### 5.2.2 Stacker belt drive

This unit intermittently drives the stacker belt to enhance stacking performance and processing speed.

The drive of the stacker belt is transmitted from the main motor via the stacker belt clutch (CLH2) and shaft coupling.

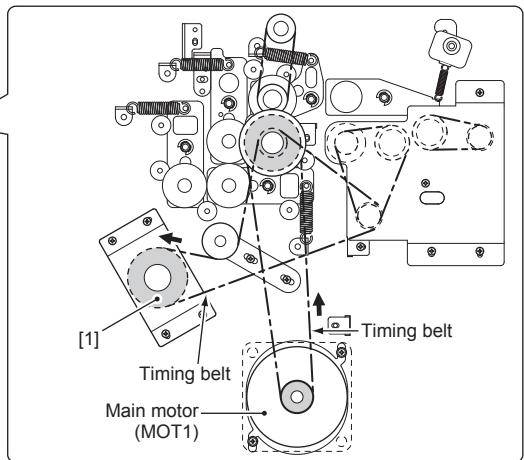
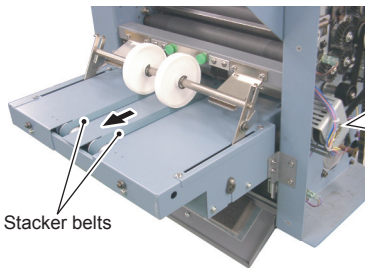

[1] Stacker belt clutch (CLH2)

<DC 24 V, electromagnetic clutch>

Transmits drive from the main motor to the stacker belt.

## 5.3 Stacker Roller Section

### 5.3.1 Configuration

#### Reference

The basic structure is the same as DF-920/915.

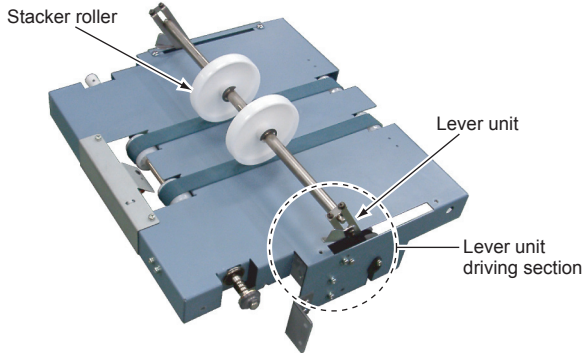

### 5.3.2 Lever unit drive

When the folded size is set on the control panel, the lever unit drives and the stacker roller moves automatically according to the finished size.

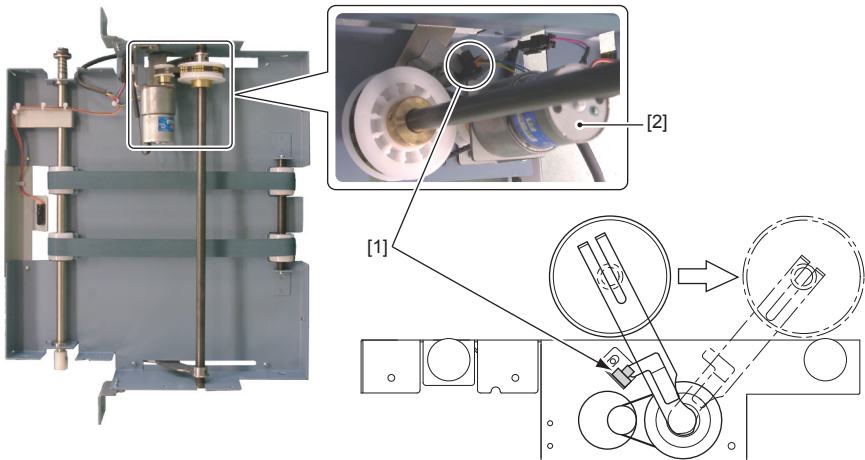

[1] Stacker roller home sensor (PS11)

<DC 5 V, photosensor>

Detects the home position of the stacker roller.

[2] Stacker roller moving motor (MOT5)

<DC 24 V, DC motor>

Motor for moving the stacker roller. Controls the distance moved by the stacker roller together with the stacker roller home sensor (PS11).

# Memo

---

# ***Chapter 3***

# ***DISASSEMBLY/ASSEMBLY***

---

# 1 EXTERNAL COVER/CONTROL SECTION

## 1.1 External Cover Section

### 1.1.1 External cover

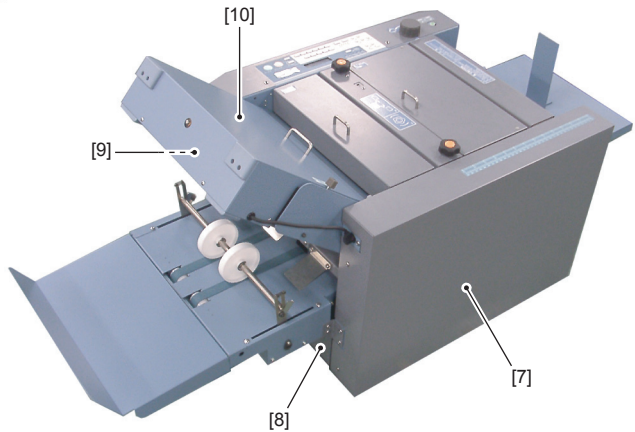
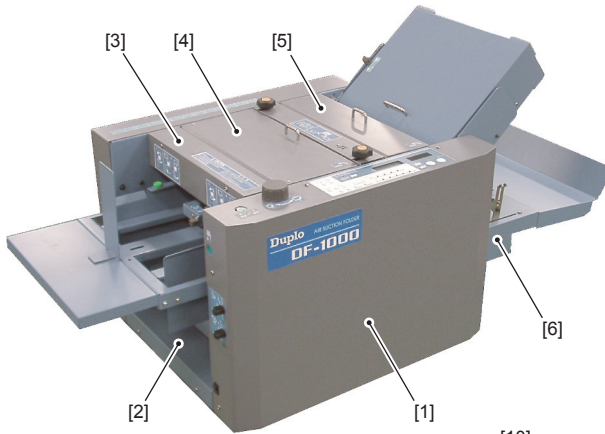

No.	Name	No. of screws	Remarks
[1]	Main cover F	6	
[2]	Paper feed lower cover	4	
[3]	Paper feed reinforcement plate cover	2	
[4]	Top cover L	1	
[5]	Top cover R	1	
[6]	Stacker side cover	4	
[7]	Main cover B	4	
[8]	Side cover	1	
[9]	Folding plate upper cover	6	
[10]	Folding plate lower cover	—	Secure together with folding plate upper cover.

## 1.2 Control Panel Section

### 1.2.1 Removing the control panel

- 1) Remove the main cover F.
- 2) Disconnect the connector of the control panel, and remove the control panel.

- [1] Screw ..... 2  
 [2] Control panel

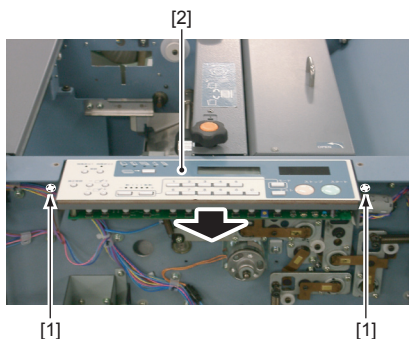

## 1.3 Board

### 1.3.1 Removing the MC unit

#### a. Precautions upon replacement

Settings are saved in the EEPROM (U1) of the MC unit.

When replacing the MC unit, remove the EEPROM (U1) from the MC unit and reinstall it in the new MC unit.

#### NOTE

If replacing the MC unit without reinstalling the EEPROM in the new one, record settings and the total count before the replacement on a backup data form (pasted inside main cover F), and perform the following after replacement.

- 1) Initializing the memory
 

While pressing the start, stop, and clear keys together, turn ON the power. This initializes all data registered in the EEPROM of the MC unit.

 Refer to "Chapter 6 MAINTENANCE MODE > 5 DATA INITIALIZATION".
- 2) Setting data
 

Reset various data in the maintenance mode as necessary, such as home position adjustment of folding plates and switching shaft, etc.

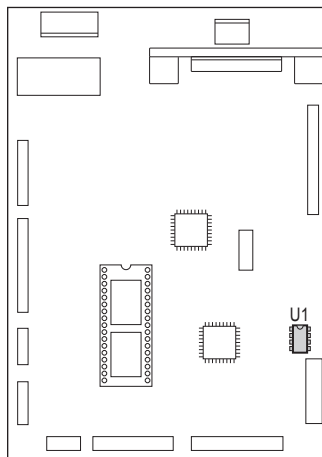

# 1 EXTERNAL COVER/CONTROL SECTION

## b. Procedure

- 1) Remove the main cover F.
- 2) Disconnect all connectors (10) on the MC unit, and remove the MC unit.

- [1] Screw ..... 4
- [2] MC unit

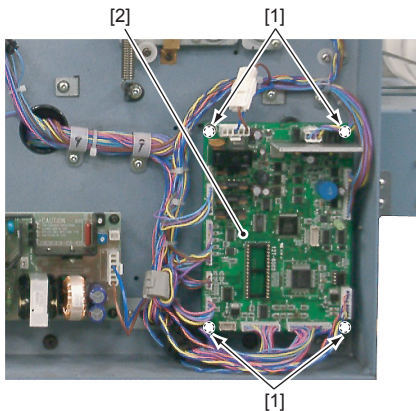

## 1.4 Power Supply/Drive

### 1.4.1 Removing the switching power supply

- 1) Remove the main cover F.
- 2) Disconnect two connectors on the switching power supply, and remove the switching power supply.

- [1] Screw ..... 4
- [2] Switching power supply

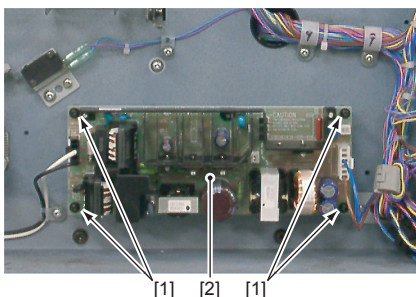

### 1.4.2 Removing the main motor (MOT1)

- 1) Remove the main cover B.
- 2) Remove the stacker unit.  
☞ Refer to “4.1.1 Removing the stacker unit”.
- 3) Remove the partitioning plate (four screws).
- 4) Loosen the fixing screws of the main motor, and remove the timing belt.

- [1] Fixing screw (Loosen) ..... 2
- [2] Timing belt ..... 1

#### NOTE

When installing the timing belt, adjust the belt tension.

☞ Refer to “Chapter 5 STANDARDS/ADJUSTMENTS > 2.2.1 Adjusting the tension of the timing belt”.

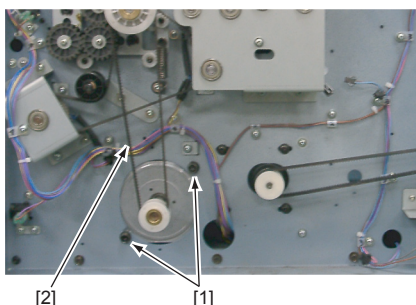



- 5) Remove the main motor.
  - [1] Fixing screw (Remove) ..... 2
  - [3] Connector
  - [4] Main motor

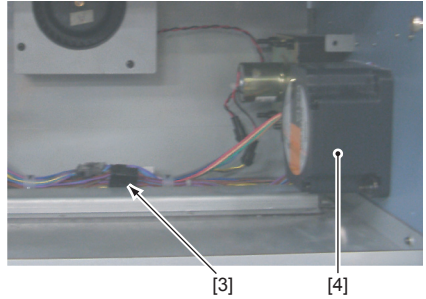

### 1.4.3 Removing the paper feed tray motor

- 1) Remove the main cover B.
- 2) Remove the stacker unit.
  - ☞ Refer to “4.1.1 Removing the stacker unit”.
- 3) Remove the partitioning plate (four screws).
- 4) Loosen the fixing screws of the paper feed tray motor, and remove the timing belt.
  - [1] Fixing screw (Loosen) ..... 4
  - [2] Timing belt ..... 1

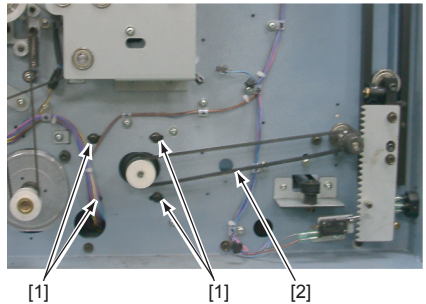

**NOTE**

When installing the timing belt, adjust the belt tension.

☞ Refer to “Chapter 5 STANDARDS/ADJUSTMENTS > 2.2.1 Adjusting the tension of the timing belt”.

- 5) Remove the paper feed tray motor.
  - [1] Fixing screw (Remove) ..... 4
  - [3] Connector
  - [4] Paper feed tray motor

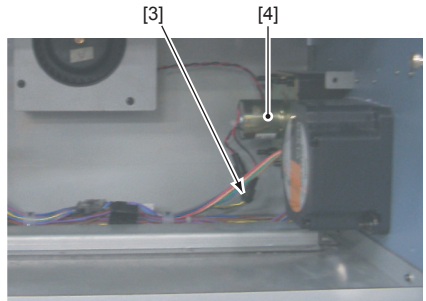

## 2 PAPER FEED SECTION

### 2.1 Paper Feed Tray Section

#### 2.1.1 Removing the PS P.W.B. unit

- 1) Remove the paper feed reinforcement plate cover.
- 2) Disconnect all connectors on the PS P.W.B. unit, and remove the PS P.W.B. unit.

- [1] Screw ..... 2
- [2] PS P.W.B. unit

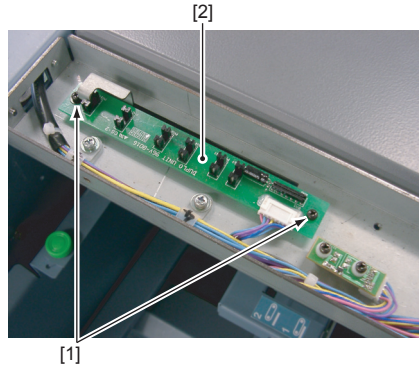

### 2.2 Suction Conveyance Section

#### 2.2.1 Removing the suction conveyance unit

- 1) Remove the main cover B.
- 2) Remove the cable clamp, and disconnect the connectors of the suction fan (FAN2) and paper feed tray sensor 1 (PS7).
- 3) Open the top cover L and remove the screws of the paper feed shaft coupling.
- 4) Move the suction conveyance unit to the non-operating side, and remove the bearing (at frame of operating side).
- 5) Remove the suction conveyance unit.  
Using the holes on the bearing removed in step 4), remove the paper feed shaft while tilting it.

**NOTE**

When installing the suction conveyance unit, perform the following adjustments.

- ☞ Refer to “Chapter 5 STANDARDS/ADJUSTMENTS > 3.2.3 Adjusting the suction conveyance unit position”.

#### 2.2.2 Removing the suction belts

- 1) Remove the secondary roller of the suction conveyance unit.
- 2) Remove the set collar and bearing on the paper feed shaft, and remove the paper feed shaft.
- 3) Remove the flat belts.

## 2.3 Registration Section

### 2.3.1 Removing the registration clutch (CLH3)

- 1) Remove the main cover B.
- 2) Remove the drive bracket and remove the bearing.
- 3) Remove the two E-rings and remove the timing belt.
- 4) Loosen the set screws (FR) of the registration clutch (CLH3).  
Loosen the two set screws securing the rotor to the registration roller.
- 5) Remove the cable clamp and remove the registration clutch (CLH3).

### 2.3.2 Removing the registration brake (BRK1)

- 1) Remove the main cover F.
- 2) Remove the stacker unit.  
 Refer to "4.1.1 Removing the stacker unit".
- 3) Remove the partitioning plate (four screws).
- 4) Loosen the nut (brake side) and remove the registration brake (BRK1).  
When loosening the nut, hold the registration roller with the hand to stop it from rotating.

### 2.3.3 Removing the registration secondary roller

- 1) Remove the main covers F and B.
- 2) Remove the lever at frame B.
- 3) Remove the registration secondary roller.

### 2.3.4 Removing the registration roller

- 1) Remove the registration clutch (CLH3).
- 2) Remove the registration brake (BRK1).
- 3) Remove the E-ring at frame B.
- 4) Remove the bearing holder from inside the frame and pull out the registration roller.

## 3 FOLDING SECTION

### 3.1 Folding Plate Section

#### 3.1.1 Removing the folding stoppers

- 1) Disconnect the folding plate connector and remove the folding plate.
- 2) Remove the folding plate lock lever.
- 3) Remove the folding plate upper cover and folding plate lower cover.
- 4) Disconnect the connectors of folding plate 1 unit and folding plate 2 unit.
- 5) Remove the fixing screws of the connecting plate (at folding plate 1 unit) and remove the folding plate 1 unit.

---

**NOTE**

Do not remove the fixing screws of the connecting plate (at folding plate 2 unit) and remove the connecting plate.

As the connecting plate is adjusted by tool at assembly, it cannot be adjusted on the market.

---

- 6) Remove each folding stopper.

---

**NOTE**

When installing the folding stopper, perform the following adjustments.

 Refer to "Chapter 5 STANDARDS/ADJUSTMENTS > 4.1.1 Adjusting the parallelity of the folding stopper".

 Refer to "Chapter 5 STANDARDS/ADJUSTMENTS > 4.1.7 Adjusting the folding stopper section".

---

#### 3.1.2 Removing the folding plate stopper motors (MOT2, MOT3)

- 1) Disconnect the folding plate connector and remove the folding plate.
- 2) Remove the folding plate lock lever.
- 3) Remove the folding plate upper cover and folding plate lower cover.
- 4) Remove the fixing screws of the connecting plate (at folding plate 1 unit) and remove the folding plate 1 unit.

---

**NOTE**

Do not remove the fixing screws of the connecting plate (at folding plate 2 unit) and remove the connecting plate.

As the connecting plate is adjusted by tool at assembly, it cannot be adjusted on the market.

---

- 5) Remove the motor bracket.
- 6) Remove the timing belt.
- 7) Remove the folding plate stopper motor.

#### 3.1.3 Removing the folding plate index sensors (PS1, PS2, PS4, PS5)

- 1) Disconnect the folding plate connector and remove the folding plate.
- 2) Remove the folding plate lock lever.
- 3) Remove the folding plate upper cover and folding plate lower cover.
- 4) Remove the fixing screws of the connecting plate (at folding plate 1 unit) and remove the folding plate 1 unit.

---

**NOTE**

Do not remove the fixing screws of the connecting plate (at folding plate 2 unit) and remove the connecting plate.

As the connecting plate is adjusted by tool at assembly, it cannot be adjusted on the market.

---

- 5) Remove the sensor bracket.
- 6) Remove the connector.
- 7) Remove the folding plate index sensor.

### 3.1.4 Removing the folding plate home sensors (PS3, PS6)

- 1) Disconnect the folding plate connector and remove the folding plate.
- 2) Remove the folding plate lock lever.
- 3) Remove the folding plate upper cover and folding plate lower cover.
- 4) Remove the fixing screws of the connecting plate (at folding plate 1 unit) and remove the folding plate 1 unit.

---

**NOTE**

Do not remove the fixing screws of the connecting plate (at folding plate 2 unit) and remove the connecting plate.

As the connecting plate is adjusted by tool at assembly, it cannot be adjusted on the market.

---

- 5) Remove the sensor bracket.
- 6) Remove the connector.
- 7) Remove the folding plate home sensor.

## 3.2 Folding Roller Section

### 3.2.1 Removing the folding rollers

- 1) Remove the folding plate.
- 2) Remove the main covers F and B.
- 3) Remove the stacker unit.  
 Refer to "4.1.1 Removing the stacker unit".
- 4) Remove the partitioning plate (four screws).
- 5) Remove the paper ejection conveyance plate unit.
- 6) Loosen the fixing screws of the main motor, and remove the timing belt.
- 7) Remove the timing pulley of the main motor.
- 8) Loosen the idler unit and remove the timing belt driving the paper feed section and paper ejection section.
- 9) Remove the spring hook hooking the spring T for the folding roller (four each at frames F and B).
- 10) Remove the four conductive plates at frame F.
- 11) Remove the stoppers (eight at frame F and seven at frame B).

---

**NOTE**

When removing the stopper, do not remove the stopper of folding roller 1.

If removed, adjust the gap with the center press roller.

 Refer to "Chapter 5 STANDARDS/ADJUSTMENTS > 4.2.2 Adjusting the gap of folding roller 1".

---

- 12) Remove the timing pulley of the jam correction knob, and remove the timing belt.
- 13) Remove the timing pulley and helical gear at frame B.

---

**NOTE**

When installing the helical gear, install from the center press roller. Remember also to insert the key.

---

### 3 FOLDING SECTION

---

- 14) Remove the key and collar.
- 15) Remove the stopper at frame B (remaining one).

---

**NOTE**

When removing the stopper, do not remove the stopper of folding roller 1.  
If removed, adjust the gap with the center press roller.

 Refer to "Chapter 5 STANDARDS/ADJUSTMENTS > 4.2.2 Adjusting the gap of folding roller 1".

---

- 16) Remove the plates (levers) at both frames F and B.
- 17) Remove the idler roller.
- 18) Remove folding roller 2.
- 19) Remove folding roller 3.
- 20) Remove the hook of spring T from the M3 screw.
- 21) Remove spring T from the switching angle, and remove the switching shaft from the switching angle.
- 22) Remove the bearing of folding roller 1.
- 23) Remove the portion fixing the paper ejection stay and main body together (frame B side).
- 24) Remove folding roller 1.  
Remove while widening the clearance between the frames slightly.
- 25) Remove the bearing holder and remove the center press roller.

## 4 PAPER EJECTION SECTION

### 4.1 Stacker Unit

#### 4.1.1 Removing the stacker unit

- 1) Remove the stacker side cover and paper ejection guide.
- 2) Open the side cover and disconnect the connector.
- 3) Remove attaching angles F and B, and remove the stacker unit.

#### 4.1.2 Removing the stacker roller home sensor (PS11)

- 1) Remove the stacker unit.
- 2) Remove the cover at the paper receiving tray.
- 3) Remove the stacker roller home sensor together with the sensor bracket.

#### 4.1.3 Removing the stacker roller moving motor (MOT5)

- 1) Remove the stacker unit.
- 2) Remove the cover at the paper receiving tray.
- 3) Disconnect the connector, and remove the motor bracket and timing pulley.
- 4) Remove the stacker roller moving motor.

#### 4.1.4 Removing the stacker belts

- 1) Remove the stacker roller home sensor.
- 2) Remove the stacker roller moving motor.
- 3) Remove the lever unit, roller, and joint, etc.
- 4) Remove the stacker belts.

---

**NOTE**

When installing the stacker belt, install according to the instructions on the rotating direction printed inside the belt.

---

# Memo



---

***Chapter 4***  
***MAINTENANCE/INSPECTION***

---

# 1 LIST OF MAINTENANCE TOOLS

## 1.1 General Tools

Tool name	Main purpose
Phillips screwdriver	General
Phillips screwdriver (Long)	
Phillips screwdriver (Stubby)	
Flat screwdriver (Small)	For removing E-rings, etc.
Long nose plier	For install E-rings, removing/installing springs, etc.
Plier	
Spanner M3 (5.5 mm across)	General
Spanner M4 (7.0 mm across)	
Box wrench M3	General
Box wrench M4	
Box wrench M5	
Hexagonal wrench (1.5 mm across)	Set collar of adjusting knobs, etc.
Hexagonal wrench (2.0 mm across)	Set collar of adjusting knobs, etc.
Thread locking (Equivalent to Three Bond 1401B)	For fixing screws
Thread locking (Equivalent to Loctite 242 (Medium strength))	For fixing screws
Thickness gauge	Gap adjustments
Level	For adjusting the paper feed tray position ☞ Refer to “Chapter 5 STANDARDS/ADJUSTMENTS > 3.1.1 Adjusting the paper feed tray position”.

## 1.2 Special Tools

There are no special tools for this unit.

## 2 PRODUCT LIFESPAN/PARTS LIFESPAN

### 2.1 Product Lifespan

Five years or 5 million sheets.

### 2.2 Parts Lifespan

This section describes parts recommended to be stocked at each service center (recommended parts) to maintain the product quality and reduce the down time.

#### 2.2.1 Recommended spare parts A (Consumables)

The following shows parts which need to be replaced more than once within the product lifespan due to consumption and wear in normal use (excluding malfunctions).

Part name	Part No.	Approximate lifespan (million sheets)				Part used/Remarks
		1	2	3	5	
Separator (Base unit)	11A-15281		○			Paper feed section

#### 2.2.2 Recommended spare parts B (Function parts)

These consist of mechanical parts with comparatively high risk of incidental malfunctions and large electrical parts.

For details, refer to the parts catalog.

#### 2.2.3 Recommended spare parts C (Drive parts)

These consist of mechanical parts with comparatively low risk of incidental malfunctions and electrical parts.

For details, refer to the parts catalog.

#### 2.2.4 Recommended spare parts D (Semi-durable parts)

The following shows parts which may need to be replaced within the product lifespan though they rarely are consumed or wear out in normal use (excluding malfunctions).

Part name	Part No.	Approximate lifespan (million sheets)				Part used/Remarks
		1	2	3	5	
Bearing	013-10024				○	Paper feed section, drive section
Bearing	013-10031				○	Paper ejection section
Bearing	013-10036				○	Folding section
Bearing	013-10039				○	Paper feed section
Bearing	013-10051				○	Drive section
Link	11A-10200				○	Paper feed section
Flat belt	11A-11393		○			
Spring C	12H-30470				○	Folding section
Pulley unit	12H-40390				○	Paper ejection section
Valve head unit	12T-24480				○	Paper feed section
Spring T	12T-24690				○	
Spring T	12T-26280				○	
Flat belt	12T-42190				○	Paper ejection section

## 3 PERIODIC MAINTENANCE

### 3.1 Basic Maintenance

To maintain the quality of this product, perform inspections at the following cycle.

- One month after installation
- Every six months or 100,000 uses

### 3.2 Cleaning

Cleaning part	Approximate cleaning time	Defect due to dirt
Upper paper sensor (PS8)	Every six months or 100,000 uses	Paper jam misdetection
Lower paper sensor (PS8)*1		
Paper feed inlet sensor (PS10)*1		
Paper ejection outlet upper sensor (PS12)*1		
Paper ejection outlet lower sensor (PS12)*1		
Suction belt*1		
Folding roller*1		
Stacker belt*1		

\*1 : Also designated as user maintenance part.

### 3.3 Oiling

Oiling part		Approximate oiling time	Oil/grease used
Overall	Whole circumference of gear	Every six months or 100,000 uses	Equivalent to Orelube G1650 grease
	Area where shaft and bearing are connected		Equivalent to Orelube G90-140 oil
Paper feed section	Sliding part of the separator unit bracket		Equivalent to Kyodoyushi unilube No. 2 grease
	Side guide up/down slide shaft		
Folding section	Area where folding roller (center press roller) and bearing are connected		Equivalent to Orelube G90-140 oil
	Area where press reference pillar and press bar are connected		
	Plate spring of folding roller end		Equivalent to Dow Corning MOLY KOTE 41 grease

---

***Chapter 5***  
***STANDARDS/ADJUSTMENTS***

---

# 1 BASIC ADJUSTMENT PROCEDURES

- 1) Perform the following checks and adjustments.
  - ☞ Refer to “4.1.1 Adjusting the parallelity of the folding stopper”.
  - ☞ Refer to “4.1.2 Adjusting the home position of the switching shaft”.
- 2) Note down the current user menu (function setting mode) and then change the user menu settings to shipment settings.
  - ☞ Refer to “Chapter 1 INTRODUCTION > 4.2 User Menu (Function Setting Mode)”.
- 3) Set paper passage conditions as follows.

Item	USA model	UK model
Paper size	8.5" × 11" (LTR)	A4
Paper type	Fine quality paper (81.4 g/m <sup>2</sup> )	
Paper grain direction	Vertical direction	
Processing speed	5 (Maximum speed)	
Side guide	Adjust to paper width	
Side guide adjusting knob	Standard position	
Skew correction knob	Standard position	
Thin paper feed button	ON	

- 4) Set the folding mode to letter fold and press the [test] key.
- 5) Measure the center of the ejected paper (second sheet), and adjust so that the following reference values are satisfied.

Reference value of folded plane length	USA model	UK model
Folded plane length [A]	93 ± 0.3 mm	98.5 ± 0.3 mm
Folded plane length [B]	94 ± 0.3 mm	99.5 ± 0.3 mm

☞ Refer to “4.1.3 Adjusting the home position of the folding stopper”.

- 6) Set the folding mode to single fold and press the [test] key.
- 7) Measure the center of the ejected paper (second sheet), and adjust so that the following reference values are satisfied.

Reference value of folded plane length	USA model	UK model
Folded plane length [C]	139.5 ± 0.5 mm	148.5 ± 0.5 mm

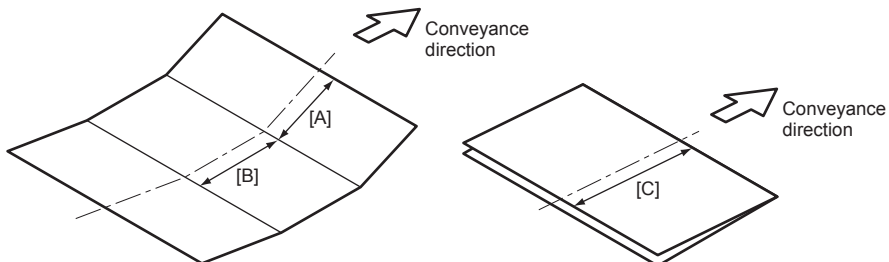

## 2 EXTERNAL COVER/CONTROL SECTION

### 2.1 External Cover Section

#### 2.1.1 Adjusting the interlock switch position

##### a. Top cover R switch (SW1)/Side cover switch (SW2)/Top cover L switch (SW5)

<Adjustment value>

When each cover is closed, the clearance [A] should be  $1.0 \pm 0.2$  mm.

- [1] Fixing screw (Loosen)..... 2  
 [2] Sensor bracket

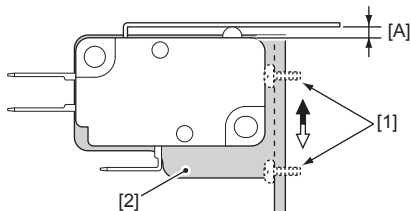

##### b. Folding plate switch (SW3)

<Adjustment value>

When the folding plate is set, the clearance [A] should be  $1.0 \pm 0.5$  mm.

- [1] Fixing screw (Loosen)..... 2  
 [2] Sensor bracket

##### c. Safety lever switch (SW7)

<Adjustment value>

When the paper feed tray is at the lower limit position, the clearance [B] should be  $0.7 \pm 0.2$  mm.

- [1] Fixing screw (Loosen)..... 2  
 [2] Sensor bracket

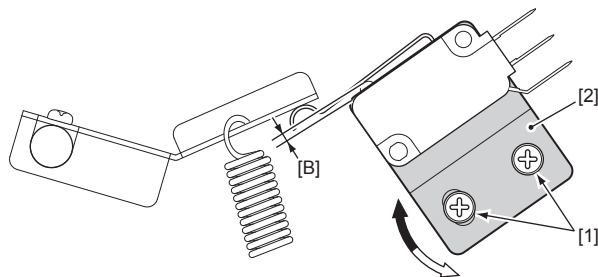

## 2.2 Drive Section

### 2.2.1 Adjusting the tension of the timing belt

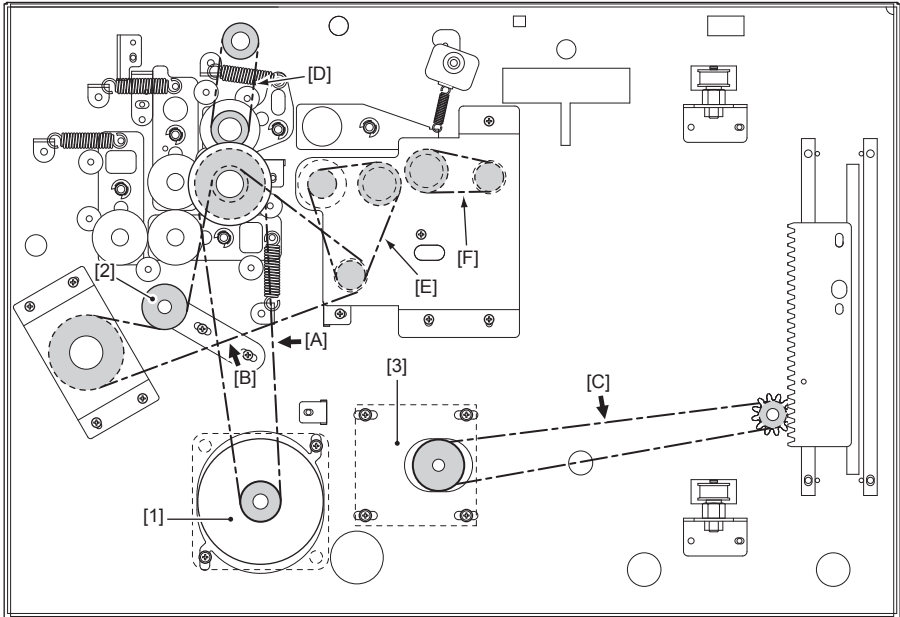

#### a. Drive belt of main motor section

<Adjustment value>

When a load of 3 N is applied vertically to the belt at measuring point [A], the slack should be 2 to 4 mm.

- [1] Main motor  
Adjusting screw ..... 2

#### b. Drive belt of registration roller, folding roller, paper ejection section

<Adjustment value>

When a load of 3 N is applied vertically to the belt at measuring point [B], the slack should be 4 to 6 mm.

- [2] Idler roller  
Adjusting screw ..... 2

#### c. Drive belt of tray up/down section

<Adjustment value>

When a load of 3 N is applied vertically to the belt at measuring point [C], the slack should be 3 to 5 mm.

- [3] Paper feed tray motor  
Adjusting screw ..... 4

#### d. Other drive belts

<Adjustment value>

Do not tauten the drive belts [D], [E], and [F] excessively.



## 2.2.2 Attaching position of motor pulley

### a. Main motor (MOT1)

Attach the motor pulley as shown in the figure.

- [1] Motor pulley
- [2] Frame B

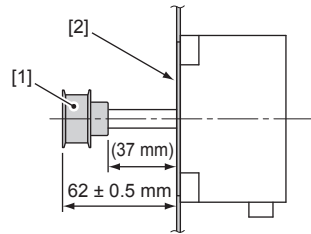

### b. Paper feed tray motor (MOT4)

Attach the motor pulley as shown in the figure.

- [1] Motor pulley

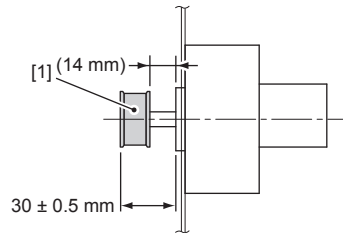

## 3 PAPER FEED SECTION

### 3.1 Paper Feed Tray Section

#### 3.1.1 Adjusting the paper feed tray position

- 1) Adjust the attaching position of the left and right racks, and set the paper feed tray horizontally.
  - [1] Rack .....Left and right one each  
(Adjusting screw .....Left and right two each)
- 2) Install the shutter and paper feed tray so that they are 90° to each other.

#### Reference

Steps 1) and 2) can be adjusted easily by using a level.

- 3) Adjust the attaching position of arm L so that the actuator of the paper feed tray home switch (SW4) and rack do not interfere.
  - [2] Arm L .....Left and right one each  
(Adjusting screw .....Left and right two each)
- 4) Adjust the height from the top surface of the paper feed tray to the stacking upper limit mark [A] on the side guides.

At this time, check that the clearance between the stopper plate and arm is 1.5 to 3.5 mm.

<Adjustment value>  
100 to 102 mm

  - [3] Stopper plate
- 5) Adjust the attaching position so that the paper feed tray home switch (SW4) turns ON at step 4).
  - [4] Fixing screw (Loosen) ..... 2
  - [5] Sensor bracket

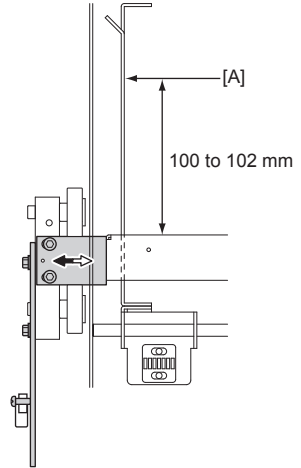
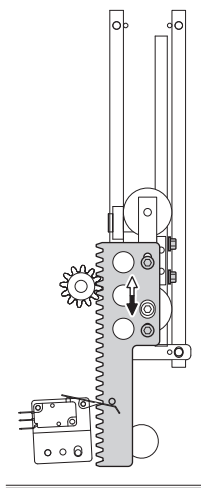
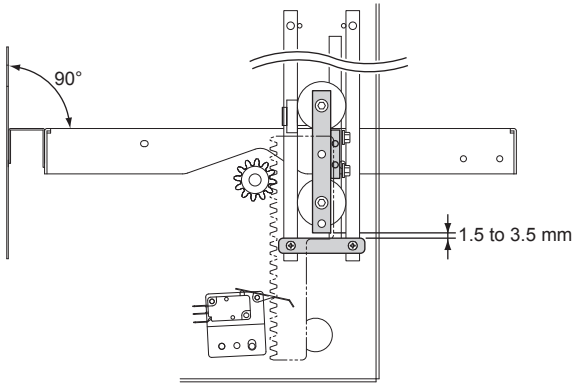

### 3 PAPER FEED SECTION

#### 3.1.2 Adjusting the side guide

- 1) Adjust the position of the plate so that the following conditions are met and secure.  
The left and right side guides should be symmetrical to the center of the two frames.  
The left and right side guides should be parallel to each other and at the same time vertical to the paper feed tray.
- 2) To adjust the tension of the belt for moving, position and secure the timing pulley so that when a load of 1 N (102 gf) is applied near the belt center [A] with a 5 N (510 gf) tension gauge, the belt slackens by 3 to 5 mm.

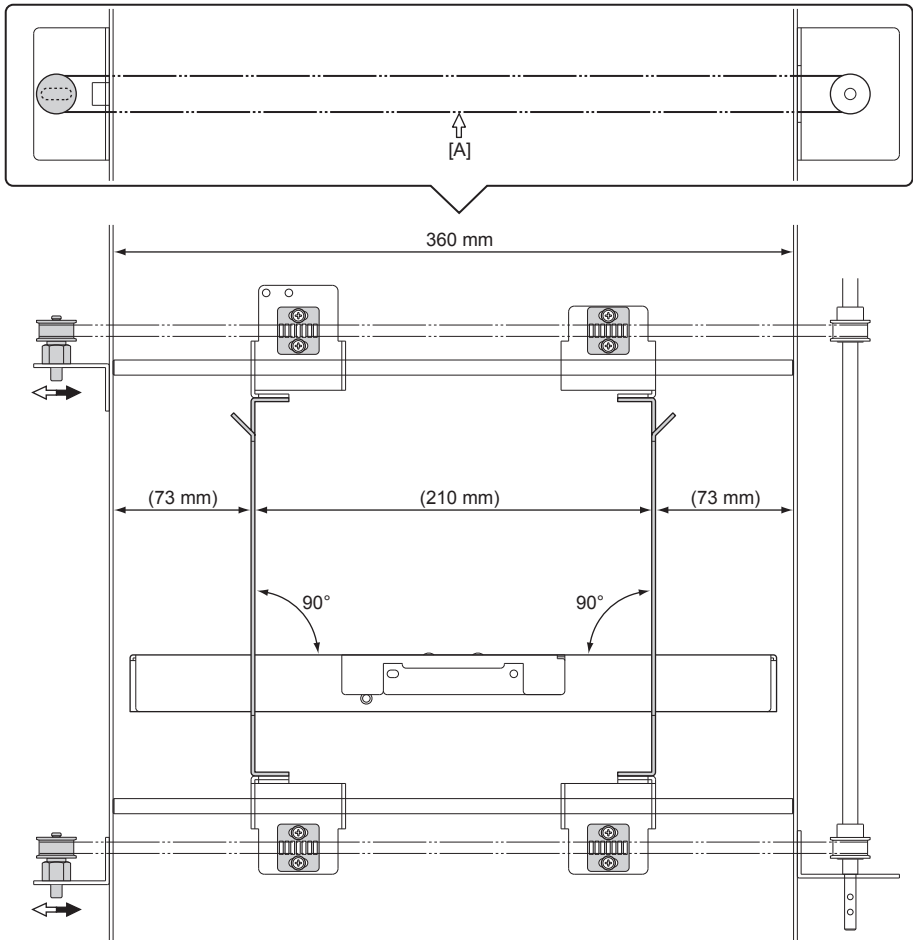

## 3.2 Suction Conveyance Section

### 3.2.1 Adjusting the separating air adjusting knob position

- 1) Loosen the set screw of the separating air adjusting knob.
  - [1] Separating air adjusting knob  
(Set screw)
- 2) Slide the shutter in the arrow direction until it stops.
  - [2] Shutter
- 3) Adjust the separating air adjusting knob to "1", and tighten the set screw.

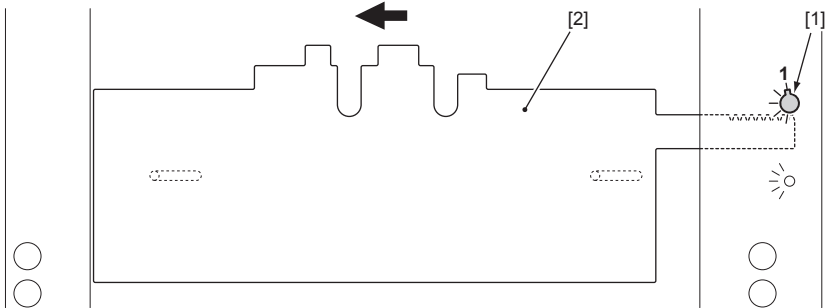

### 3.2.2 Adjusting the separator adjusting knob position

- 1) Loosen the set screw of the separator adjusting knob.
  - [1] Separator adjusting knob  
(Set screw)
- 2) Slide the bracket in the arrow direction until it stops.
  - [2] Bracket
- 3) Adjust the separator adjusting knob to "1", and tighten the set screw.

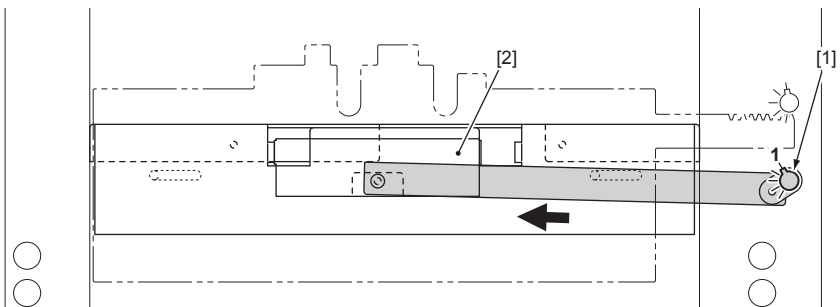

#### 3.2.3 Adjusting the suction conveyance unit position

- 1) Touch the angle [3] against the duct [4] so that the top surface [1] of the paper feed tray and suction belt surface [2] become parallel, and then secure the angle.
- 2) When the suction conveyance unit is lifted, secure so that there is a clearance of about 1 mm between the paper feed tray upper limit switch (SW6) and switch lever.

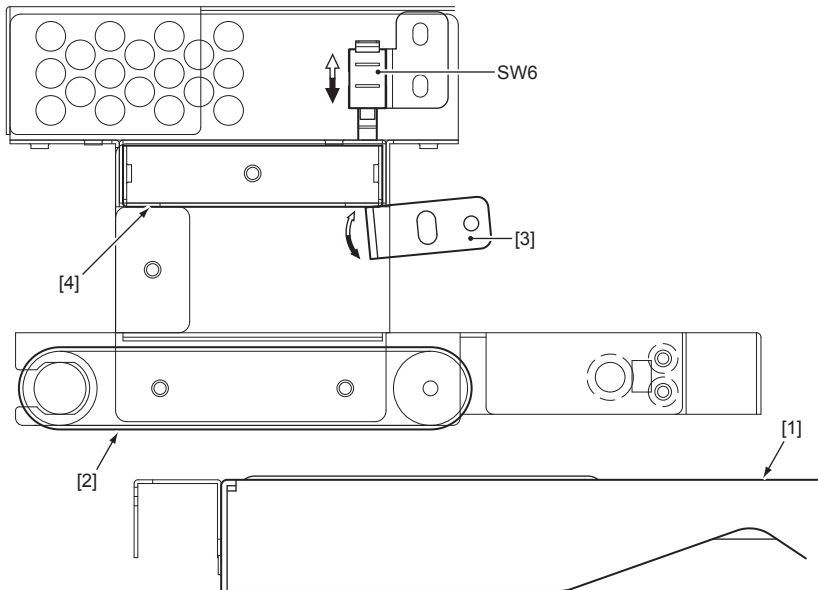

#### 3.2.4 Adjusting paper feed tray sensor 1 (PS7) position

- 1) Loosen the fixing screws of the plate [1].
  - 2) Move the level sensor adjusting lever [2], and adjust the distance between the top surface of the paper feed tray [3] and paper feed bracket [4] as shown in the figure. Raise the paper feed tray in the maintenance mode.
- ☞ Refer to “Chapter 6 MAINTENANCE MODE > 3 MENUS AND FUNCTIONS”.
- 3) Adjust the attaching position of the plate [1] so that the level sensor adjusting lever [2] does not exceed the distance in step 2).

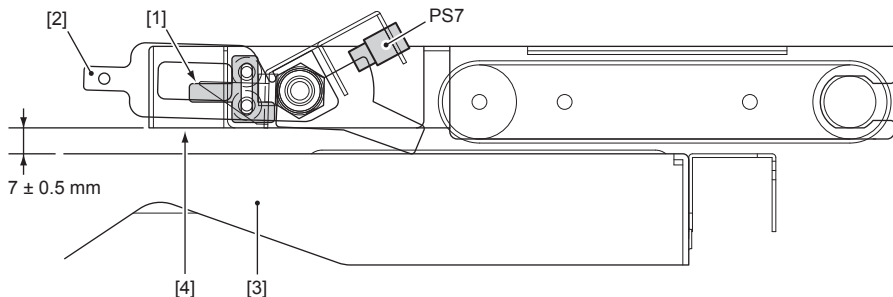

### 3.2.5 Adjusting the suction solenoid (SOL1) position

Adjust the attaching position of solenoid base [1] so that when the suction solenoid (SOL1) is ON, the following state is set.

<Adjustment value>

- Clearance [A] between the solenoid and plunger is 0 to 0.5 mm.
- The valve head [2] is completely blocking the suction box [3] square hole.

- [1] Solenoid base  
(Fixing screw ..... 2)
- [2] Valve head
- [3] Suction box

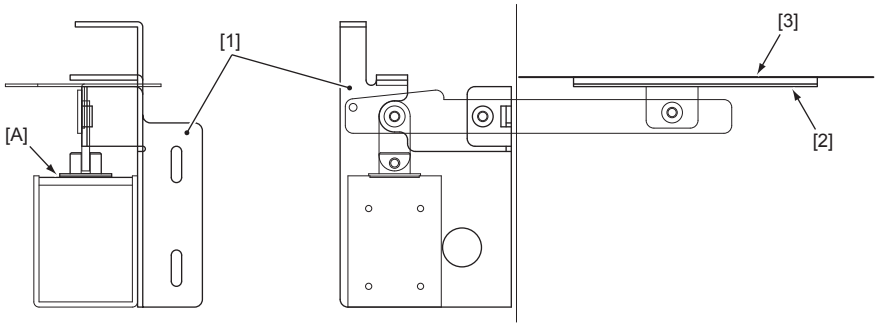

### 3.2.6 Adjusting paper feed tray sensor 2 (PS9) position

<Adjustment value>

Adjust so that when the lever protrusion amount [A] from the shutter is  $1 \pm 0.2$  mm, it is detected by the sensor.

- [1] Shutter
- [2] Lever
- [3] Sensor bracket  
(Adjusting screw ..... 2)

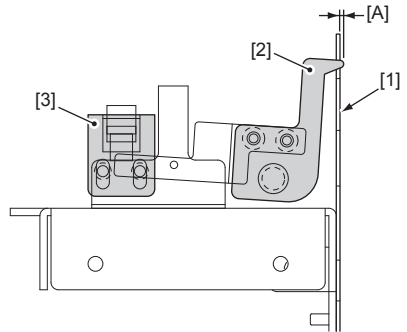

## 4 FOLDING SECTION

### 4.1 Folding Plate Section

#### 4.1.1 Adjusting the parallelity of the folding stopper

Adjust the parallelity of the lead edge of paper and folding stoppers of folding plates 1 and 2 to reduce folding misalignment along the sides of the paper.

- 1) Remove the folding plate from the main body, and remove the folding plate upper cover and folding plate lower cover.  
Install the folding plate to the main body with the covers removed.
- 2) Open the top covers L and R.  
Place paper, etc. between the top cover L switch (SW5) and top cover R switch (SW1) detector and set each switch to ON.

**NOTE**

After completing the adjustment, check that each switch is able to detect the open/close of the top cover normally.

- 3) Turn ON the power and set the paper passage conditions as follows.  
Items not included in the following table will not affect this adjustment.

Item	USA model	UK model
Paper size	8.5" × 11" (LTR)	A4
Paper type	Fine quality paper (81.4 g/m <sup>2</sup> )	
Paper grain direction	Vertical direction	
Separator adjusting knob	5	
Side guide	Adjust to paper width	
Side guide adjusting knob	Standard position	
Skew correction knob	Standard position	

- 4) Align paper neatly and stack on the paper feed tray, and adjust the side guides to the paper width.

**NOTE**

If the side guides are not adjusted to the paper width, folding misalignment along the sides of the paper will occur.

- 5) Select "28 . ALIGNMENT" of the maintenance mode, and press the [start] key.  
 Refer to "Chapter 6 MAINTENANCE MODE > 3.1 Menu List".  
 The paper feed tray rises and the folding plate 1 folding stopper and folding plate 2 folding stopper move to their home positions.
- 6) Insert one sheet of paper on the paper feed tray into the unit by hand.  
Insert until the paper lead edge touches the conveyance roller.
- 7) Rotate the conveyance roller by hand to convey the paper.  
Convey until the paper lead edge touches the registration secondary roller.
- 8) Rotate the registration secondary roller by hand to convey the paper.  
Convey until the paper lead edge touches the idler roller.



- 9) Rotate the jam correction knob to convey the paper.  
 Convey to the position just before the paper lead edge touches the slide stopper [1] of the folding plate 1 folding stopper.

**NOTE**

If paper skews during conveyance, check the nip amount of the idler roller.

☞ Refer to “4.2.3 Checking the folding roller nip”.

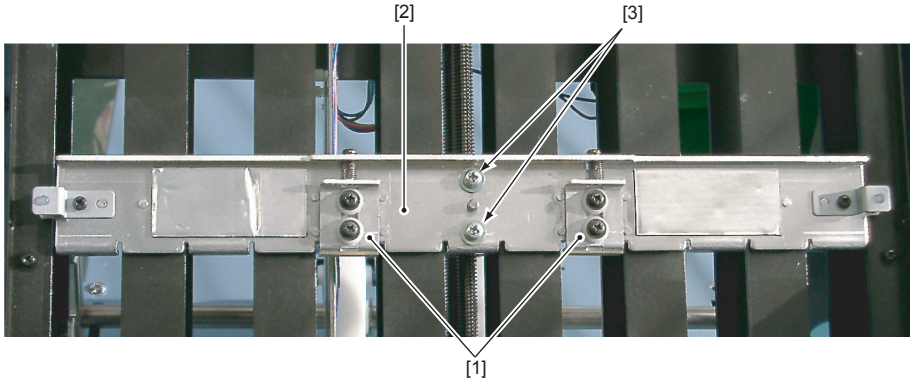

- 10) Adjust the attaching position of the folding plate 1 folding stopper [2] so that it is parallel to the paper lead edge.

- [2] Folding plate 1 folding stopper
- [3] Fixing screw ..... 2

- 11) Rotate the jam correction knob to convey the paper.  
 Convey to the position just before the paper lead edge touches the slide stopper of the folding plate 2 folding stopper.
- 12) Check the parallelism of the folding plate 2 folding stopper and paper lead edge.
- 13) Turn OFF the power and remove the folding plate 1 unit.  
 ☞ Refer to “Chapter 3 DISASSEMBLY/ASSEMBLY > 3.1.1 Removing the folding stoppers”.
- 14) Adjust the attaching position of the folding plate 2 folding stopper.  
 The adjustment method is the same as the folding plate 1 folding stopper.
- 15) Install the folding plate 1 unit and install the folding plate to the main body.
- 16) Perform from step 3) and check that the parallel adjustment of each folding stopper has been completed appropriately.

## 4 FOLDING SECTION

### 4.1.2 Adjusting the home position of the switching shaft

In the single fold mode, folding is not carried out by folding plate 2.

The switching shaft restricts paper conveyance so that paper does not enter the folding plate 2 unit in the single fold mode.

#### Reference

If this adjustment is not carried out appropriately, problems may occur in the single fold mode. These problems include paper jam at the folding roller and flattening of the lead edge of folded paper.

In the single folding of thin paper, one folding wrinkle line occurs near the 15 mm position from the folded line.

- 1) Check or adjust the attaching position of the switching adjusting plate.  
☞ Refer to “4.1.8 Adjusting the attaching position of the switching adjusting plate”.
- 2) Enter the maintenance mode.
- 3) Check that the “3.SW BAR ADJUST” correction value of the maintenance mode is the same as “backup data form value”.  
☞ Refer to “Chapter 6 MAINTENANCE MODE > 3.1 Menu List”.
- 4) Press the [clear] key while pressing the [stop] key.  
The folding stopper executes initial operations and the folding plate 2 folding stopper moves to the home position of the switching shaft.

- 5) Press the [speed] key and correct the home position of the switching shaft.

With the folding plate 2 folding stopper at the home position of the switching shaft, perform the following correction.

<Adjustment value>

When the switching shaft [1] is gently pressed by finger, the switching shaft should move slightly (clearance between switching shaft tip and folding roller 2 should be 0.2 to 0.4 mm).

#### Speed key [+]:

Pressing the key once distances the switching shaft from folding roller 2 by 0.125 mm.

#### Speed key [-]:

Pressing the key once moves the switching shaft nearer to folding roller 2 by 0.125 mm.

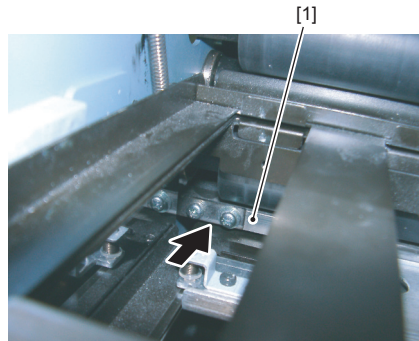

#### NOTE

If the switching shaft is touching folding roller 2 (the switching shaft does not move even when pressed gently by finger), folding roller 2 may get damaged.

- 6) Press the [clear] key while pressing the [stop] key.  
The folding stopper executes initial operations and the folding plate 2 folding stopper moves to the home position of the switching shaft.

### 4.1.3 Adjusting the home position of the folding stopper

- 1) Enter the maintenance mode.
- 2) Check that the following correction value is the same as "backup data form value".  
☞ Refer to "Chapter 6 MAINTENANCE MODE > 3.1 Menu List".

**Folding plate 1 folding stopper:**

Check the correction value of "1.STOP1 DEFAULT".

**Folding plate 2 folding stopper:**

Check the correction value of "2.STOP2 DEFAULT".

- 3) Press the [clear] key while pressing the [stop] key to execute initial operations of the folding stopper.
- 4) Press the [test] key to execute test folding.
- 5) Measure the folded plane length of the ejected paper (second sheet).
- 6) Press the [speed] key and correct the folded plane length.  
**Speed key [+]:**  
Pressing the key once increases the folded plane length by 0.125 mm.  
**Speed key [-]:**  
Pressing the key once decreases the folded plane length by 0.125 mm.
- 7) Repeat steps 3) to 6) until the respective folded plane length becomes the reference value.

## 4 FOLDING SECTION

### 4.1.4 Checking the conveyance path gap of folding plate

If the conveyance path gap of the folding plate does not meet the specified value, a part may be deformed. Continuing use in this state can result in paper jams and folding problems. Be sure to change the concerned part.

<Specified value>

The conveyance path gap within the 120 mm range from the center of the folding plate should be the following value.

[A] Folding plate 1 : 1.6 mm ( $+0.3$   
 $-0.1$  mm)

[B] Folding plate 2 : 1.6 mm ( $+0.3$   
 $-0.1$  mm)

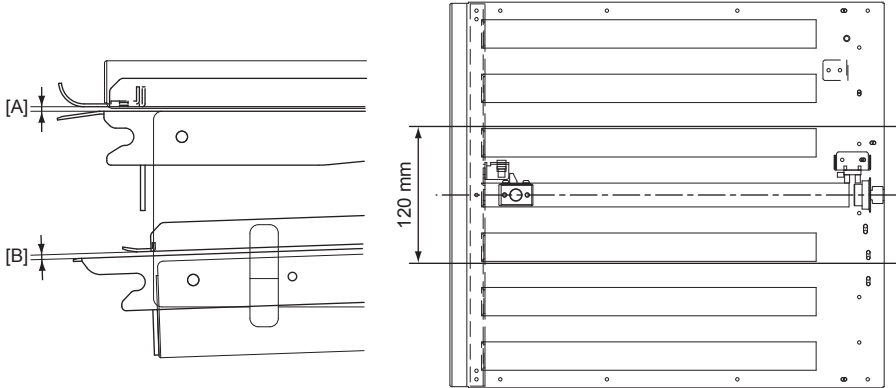

### 4.1.5 Adjusting the gap of the screw shaft unit

When attaching the screw shaft unit [1] to the folding plate, insert a shim in the space [A] between the chassis [2] (motor side) and bearing [3], and adjust the thrust play to the following value.

<Adjustment value>

More than 0.1 mm but less than 0.15 mm.

(Thickness gauge of 0.1 can be inserted but not 0.15.)

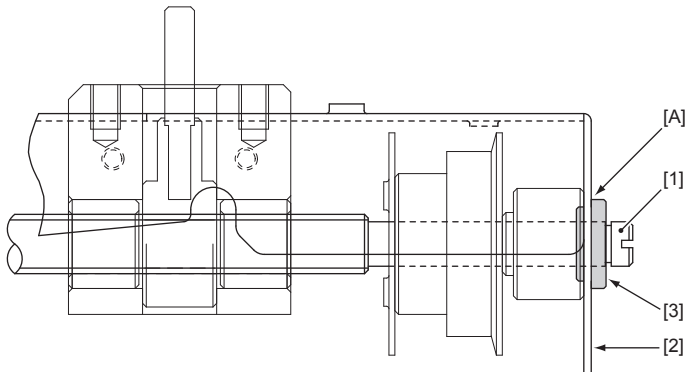

### 4.1.6 Adjusting the motor deceleration pulley section

#### a. Gap adjustment

Insert a shim in the space [A] between the idler pulley [1] and E-ring [2], and adjust the thrust play to the following value.

<Adjustment value>

0.1 to 0.3 mm

#### b. Adjusting the tension of deceleration timing belts 1 and 2

<Adjustment value>

When a load of 3 N is applied to the timing belt at measuring points [B] and [C], the respective slack should be 2 to 3 mm.

[3] Deceleration timing belt 1

[4] Deceleration timing belt 2

[5] Motor deceleration pulley

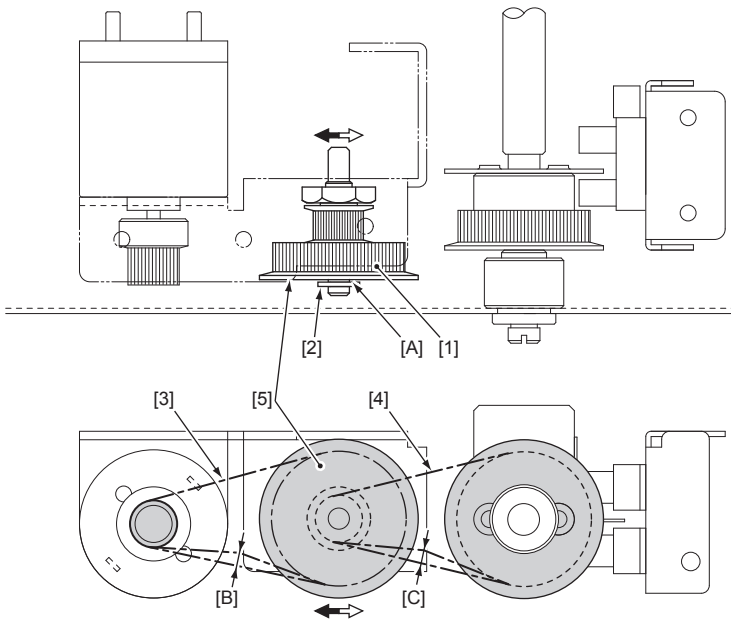

## 4 FOLDING SECTION

### 4.1.7 Adjusting the folding stopper section

#### a. Fixing the collar

<Specified value>

Tightening torque of screw is 0.69 Nm.

- [1] Collar ..... 2
- (Screw ..... 2)

#### NOTE

Apply a very small amount of thread locking to the collar fixing screw from the back of the folding stopper.

(Equivalent to Three Bond 1401B)

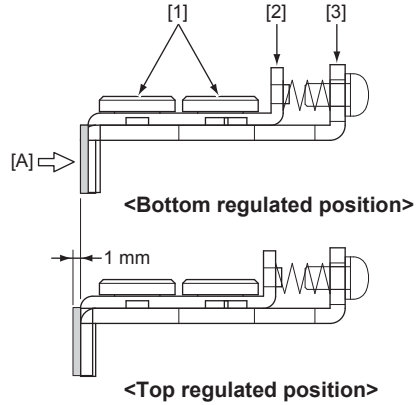

#### b. Checking the operations of the slide stopper

When the measuring point [A] is pressed with a load of 0.25 N, the slide stopper should move smoothly to the bottom regulated position. When the load is removed, the slide stopper should return to the top regulated position immediately.

- [2] Slide stopper
- [3] Folding stopper

### 4.1.8 Adjusting the attaching position of the switching adjusting plate

Secure the switching adjusting plate of the folding plate 2 folding stopper pushed towards the arrow direction in the figure, paying attention to the parallelity of the left and right sides.

- [1] Switching adjusting plate
- (Screw ..... 2)

#### NOTE

Apply a very small amount of thread locking to the fixing screw of the switching adjusting plate.

(Equivalent to Loctite 242: Medium strength)

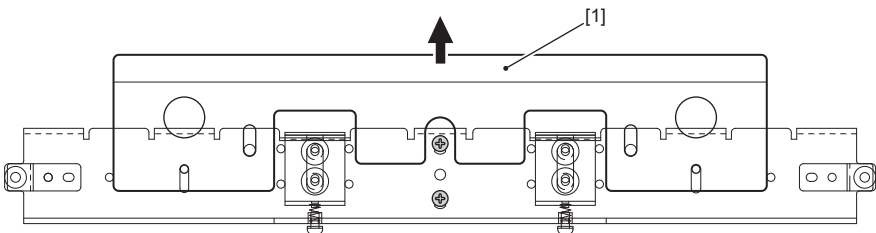

## 4.2 Folding Roller Section

### 4.2.1 Adjusting the attaching position of the press spring T

<Adjustment value>

Secure the spring hook at the position shown in the figure, and attach the press spring T.

- [1] Spring hook .....Four each in front and rear
- [2] Press spring T .....Four each in front and rear
- [3] Idler roller .....Eight each in front and rear

#### Reference

If extreme folding misalignment along the sides of the paper occur, check the balance between the front and rear pressure, and adjust by changing the spring hooking direction.

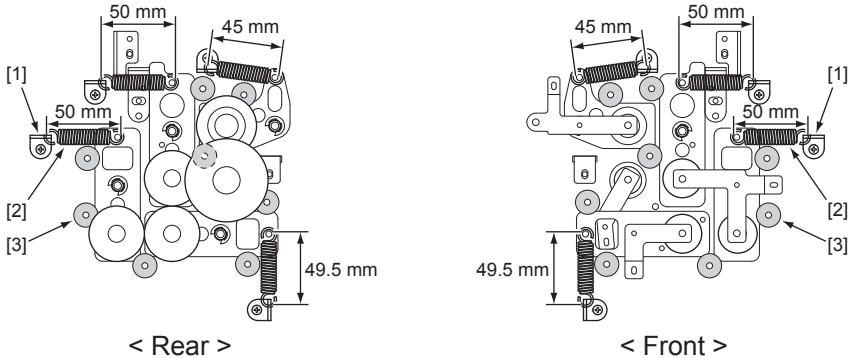

### 4.2.2 Adjusting the gap of folding roller 1

Adjust the gap in all directions centering around folding roller 1 and center press roller so that when a sheet of fine quality paper (81.4 g/m<sup>2</sup>) is inserted and removed gently, two sheets are properly gripped one over the other. (Reference value: Gap between 0.1 to 0.2 mm)

- [1] Adjusting screw
- [2] Folding roller 1
- [3] Center press roller

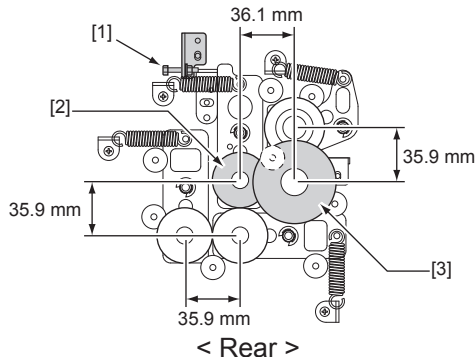

## 4 FOLDING SECTION

### 4.2.3 Checking the folding roller nip

- 1) Apply press force to all folding rollers.
- 2) Rotate the folding rollers for one round.
- 3) Check that the following value is satisfied between the folding rollers (excluding folding roller 1).

<Adjustment value>

- Nip amount [A] (left, center, right) should be uniform at three locations.
- Backlash [B] on the whole circumference of the drive gear should be 0.1 to 0.2 mm.

- [i] Idler roller
- [c] Center press roller
- [1] Folding roller 1
- [2] Folding roller 2
- [3] Folding roller 3

#### NOTE

If the nip amount is not uniform, it may cause folding misalignment along the sides of the paper, and wrinkling of the folded line. In this case, adjustment attaching position of press spring T of the concerned roller and adjust the nip amount uniform.

☞ Refer to “4.2.1 Adjusting the attaching position of the press spring T”.

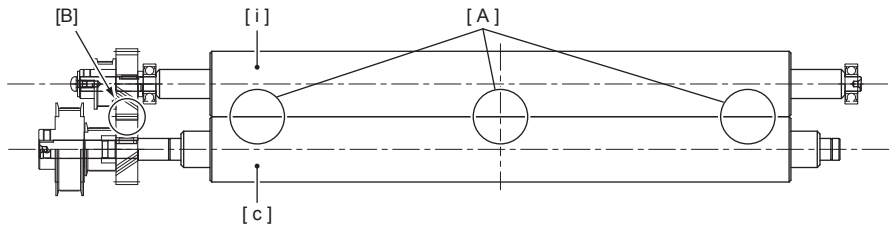
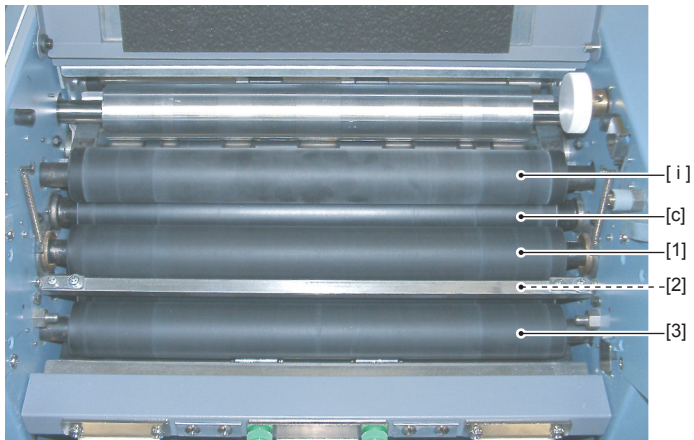



#### 4.2.4 Adjusting the attaching position of the conveyance plate

Press the conveyance plate in the arrow direction shown in the figure and secure.

<Specified value>

Gap between the conveyance plate and folding roller 1 is 0.2 mm.

- 1) Letter fold of A3 or 11" × 17" (LGR) fine quality paper (157 g/m<sup>2</sup>).
- 2) Sandwich the paper made in step 1) between the conveyance plate and folding roller, and secure the conveyance plate.

[1] Conveyance plate  
(Screw ..... Two each in front and rear)

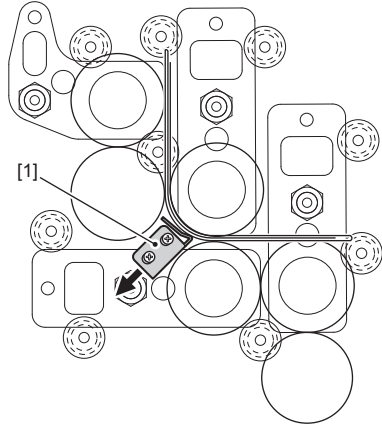

#### 4.2.5 Adjusting the connecting plate

##### NOTE

Do not remove the fixing screws of the connecting plate (at folding plate 2 unit) and remove the connecting plate.

As the connecting plate is adjusted by tool at assembly, it cannot be adjusted on the market.

If the folding plate has been replaced, the new folding plate may be difficult to set on the main body of the unit. In this case, adjust as follows.

- 1) Remove the folding plate and loosen fixing screws [B1] and [B2].

[B1] Fixing screw .....One each in front and rear

[B2] Fixing screw .....One each in front and rear

##### NOTE

While the [B1] and [B2] fixing screws are loosened, never loosen fixing screws [A1] and [A2].

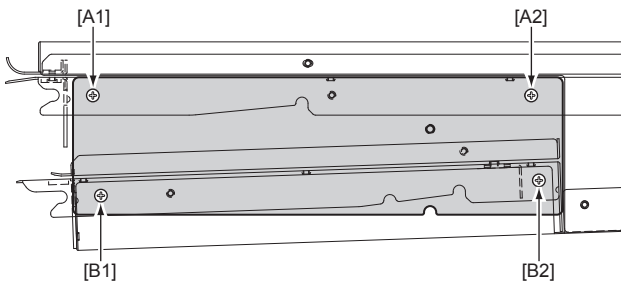

- 2) In the state of step 1), attach the folding plate to the main body of the unit.
- 3) Tighten the fixing screw [B2].  
Secure with the folding plate attached to the main body.
- 4) Remove the folding plate and tighten fixing screw [B1].

## 5 PAPER EJECTION SECTION

### 5.1 Stacker Belt Section

#### 5.1.1 Adjusting the tention of the stacker belt

<Adjustment value>

Tighten the belt so that the skew of the belt and repeated deviation of the belt to the left and right sides are within 2 mm.

- [1] Fixing screw (Loosen) ..... 2

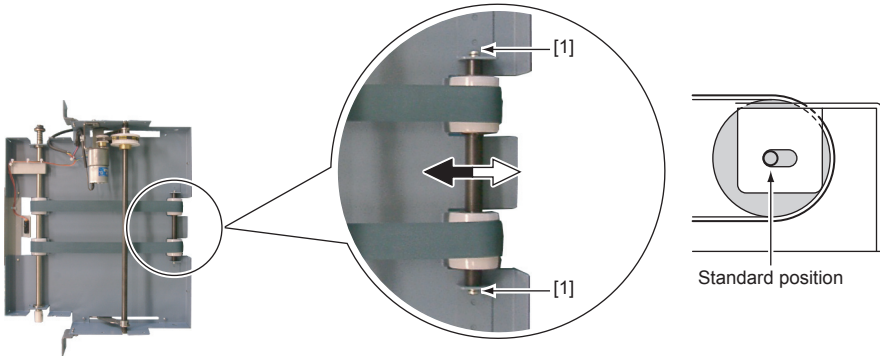

### 5.2 Stacker Roller Section

#### 5.2.1 Adjusting the tention of the timing belt

<Adjustment value>

Gap [A] between shafts is  $39.7 \pm 0.5$  mm.

- [1] Adjusting screw ..... 2
- [2] Motor bracket

#### 5.2.2 Adjusting the stacker roller home sensor (PS11) position

<Adjustment value>

Secure at top of long hole.

- [3] Adjusting screw ..... 2
- [4] Sensor angle

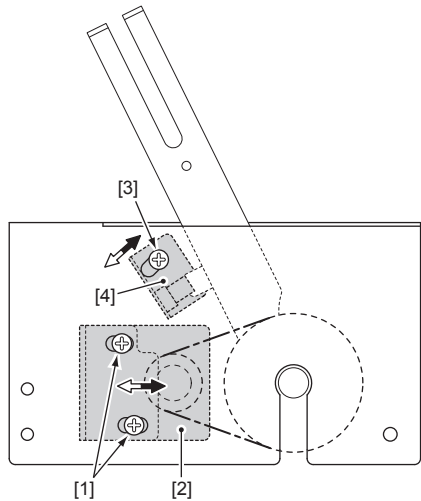

---

# ***Chapter 6***

## ***MAINTENANCE MODE***

---

# 1 OUTLINE

This unit has the following functions to ensure smooth servicing work.

- Maintenance menu
- Data initialization

The maintenance menu of this unit can broadly be divided into the following four types. Data initialization is used for erasing data in the EEPROM (U1) when problems occur.

### a. Adjustment

Menu for adjusting each part.  
(Code No. 1 to 3, 11, 12, 28)

### b. Settings

Menu for performing function settings such as destination, display unit, display language settings, changing standard settings of the user menu, checking the total counter, checking the program version, etc.  
(Code No. 4 to 10, 14 to 16)

### c. Version upgrade

Menu for upgrading the program version.  
(Code No. 18)

### d. Test checks

Menu for checking operations such as LEDs, 7-segment window, switches, sensors, motors, clutches, etc.  
(Code No. 21 to 27, 31 to 36)

## 2 MAINTENANCE MODE OPERATIONS

### 2.1 Entering the Maintenance Mode

There are two ways of entering the maintenance mode.

#### a. Method 1

- 1) Turn off the power switch.
- 2) While pressing the [start] and [stop] keys together, turn ON the power switch.  
Upon entering the maintenance mode, "MAINTENANCE MENU" will appear on the LCD.

#### b. Method 2

- 1) Enter "920" using the numerical keys while the initial screen (or error message) is displayed.
- 2) While pressing the [stop] key, press the [folding mode] key.  
Upon entering the maintenance mode, "MAINTENANCE MENU" will appear on the LCD.

### 2.2 Exiting the Maintenance Mode

#### a. Method 1

- 1) Turn off the power switch.

#### b. Method 2

- 1) Press the [clear] key two times continuously.

## 3 MENUS AND FUNCTIONS

### 3.1 Menu List

The first two digits of the menu name indicate the code number when entering a menu from the maintenance mode.

The “\*” in the “Setting (2nd line display)” column of the table below indicates the value when initializing the EEPROM.

Input of code number	: Numerical keys
Confirmation of code number	: [Folding mode] key
Selection of setting	: [Speed] key (+/-)
Switching to the next screen	: [Custom folding registration 1] key
Switching to the previous screen	: [Custom folding registration 2] key

#### Reference

If the code number is unknown, press the [custom folding registration] key (1 or 2) to display it in the order of the code number.

Maintenance menu (1st line display)	Setting (2nd line display)	Contents/Remarks
1.STOP1 DEFAULT	-20 to +20 (0*)	Mode for adjusting the home position of folding plate 1. ☞ Refer to “Chapter 5 STANDARDS/ADJUSTMENTS > 4.1.3 Adjusting the home position of the folding stopper”.
2.STOP2 DEFAULT	-20 to +20 (0*)	Mode for adjusting the home position of folding plate 2. ☞ Refer to “Chapter 5 STANDARDS/ADJUSTMENTS > 4.1.3 Adjusting the home position of the folding stopper”.
3.SW BAR ADJUST	-20 to +5 (0*)	Mode for adjusting the home position of the switching shaft. ☞ Refer to “Chapter 5 STANDARDS/ADJUSTMENTS > 4.1.2 Adjusting the home position of the switching shaft”.
4.AREAS	JAPAN* USA UK	Mode for setting the destination. At shipment, this is set according to the destination of the unit.  <b>NOTE</b> If this setting has been changed, be sure to change the following setting as well if required. ● “5. SET MM/INCH” ● “6. LANGUAGES”
5.SET MM/INCH	MILLIMETER* INCH	Mode for setting the unit of the size displayed on the LCD. At shipment, this is set according to the destination of the unit. Japanese model : MILLIMETER USA model : INCH UK model : MILLIMETER

Maintenance menu (1st line display)	Setting (2nd line display)	Contents/Remarks
6.LANGUAGES	JAPANESE ENGLISH*	Mode for setting the language of the messages displayed on the LCD. At shipment, this is set according to the destination of the unit. Japanese model : JAPANESE USA model : ENGLISH UK model : ENGLISH
7.TEST FOLD QTY	1 to 3 SHEETS (2 SHEETS*)	Mode for setting the number of sheets to be test folded.
8.BACK LIGHT OFF	15 SEC 30 SEC* 60 SEC KEEP LIGHT ON	Mode for setting the time for the LCD backlight to go OFF automatically when not using the unit.
9.BUZZ ON/OFF	ON* OFF	Mode for setting ON/OFF the buzzer which sounds during key operations, when a process ends, or when errors occur (excluding motor problems).
10.POWER ON BUZZ	OFF* 5 MIN 15 MIN 30 MIN	Mode for setting the time to sounding a buzzer to alert that the power is still ON when the unit is not used.
11.SAG	9 to 17P (13P*)	Mode for adjusting the slack of the paper at the registration roller. When the pulse count of the main motor becomes the designated setting value after the lead edge of the paper passes the paper feed inlet sensor (PS10), the registration clutch (CLH3) turns ON. The greater the setting value, the larger the paper slack will be.
12.TRAY DOWN	DOWN STAY*	Mode for setting whether to lower the paper feed tray when this unit detects no paper during standby.
14.TOTAL COUNTER	0000000*	Displays the total number of sheets fed into the machine (max. 9999999).
15.MC ROM VER	12T-8####	Displays the program version of the MC unit.
16.PANEL ROM VER	12#8####	Displays the program version of the control panel.
18.PROG VER UP		Mode for upgrading the program version. ☞ Refer to "4 UPGRADING THE PROGRAM VERSION".

### 3 MENUS AND FUNCTIONS

Maintenance menu (1st line display)	Setting (2nd line display)	Contents/Remarks
21.MOTOR TEST	MAIN BIN EJECT	<p>Mode for checking the operations of the following motors.</p> <p><b>NOTE</b> _____ The motor will not operate if any one interlock switch is not closed. _____</p> <p><b>Main motor (MOT1)</b></p> <ul style="list-style-type: none"> <li>○ [Start] key Main motor starts rotating.</li> <li>○ [Stop] key Main motor stops.</li> <li>○ Speed key [+]/[-] Main motor rotating speed changes.</li> </ul> <p><b>Paper feed tray motor (MOT4)</b></p> <ul style="list-style-type: none"> <li>○ Folding plate 1 folding stopper adjusting key [+] Paper feed tray rises.</li> <li>○ Folding plate 1 folding stopper adjusting key [-] Paper feed tray descends.</li> </ul> <p><b>Stacker roller moving motor (MOT5)</b></p> <ul style="list-style-type: none"> <li>○ Folding plate 2 folding stopper adjusting key [+] Stacker roller moves outside (away from paper ejection section).</li> </ul> <p><b>NOTE</b> _____ If the stacker roller is fed too outside, the motor locks. _____</p> <ul style="list-style-type: none"> <li>○ Folding plate 2 folding stopper adjusting key [-] Stacker roller moves inside (home position side).</li> </ul>



Maintenance menu (1st line display)	Setting (2nd line display)	Contents/Remarks
22.F.PLATE MOTOR	1:####/2:####	<p>Mode for checking the operations of the stopper motors of folding plates 1 and 2. The motor rotates while the key is pressed, and stops when the key is released.</p> <p><b>NOTE</b></p> <ul style="list-style-type: none"> <li>● The motor will not operate if any one interlock switch is not closed.</li> <li>● As the motor rotates regardless of the limit detection by the home sensor and index sensor, make sure that the folding stopper does not clash into the limit section of the folding plate.</li> </ul> <hr/> <p><b>Folding plate 1 stopper motor (MOT2)</b></p> <ul style="list-style-type: none"> <li>○ Folding plate 1 folding stopper adjusting key [+] Folding stopper moves in opposite direction of the home position.</li> <li>○ Folding plate 1 folding stopper adjusting key [-] Folding stopper moves in the home position direction.</li> </ul> <p><b>Folding plate 2 stopper motor (MOT3)</b></p> <ul style="list-style-type: none"> <li>○ Folding plate 2 folding stopper adjusting key [+] Folding stopper moves in opposite direction of the home position.</li> <li>○ Folding plate 2 folding stopper adjusting key [-] Folding stopper moves in the home position direction.</li> </ul>
23.CLUTCH TEST	IN OUT REGIST	<p>Mode for checking the operations of the following clutches. The clutch operates while the key is pressed, and stops when the key is released.</p> <p><b>NOTE</b></p> <ul style="list-style-type: none"> <li>● The clutch will not operate if any one interlock switch is not closed.</li> <li>● Do not leave the unit with the clutch operating. Otherwise, the clutch will overheat, resulting in malfunction.</li> </ul> <hr/> <p><b>Paper feed clutch (CLH1)</b> Operates with the [start] key.</p> <p><b>Stacker belt clutch (CLH2)</b> Operates with the [stop] key.</p> <p><b>Registration clutch (CLH3)</b> Operates with the [test] key.</p>

### 3 MENUS AND FUNCTIONS

Maintenance menu (1st line display)	Setting (2nd line display)	Contents/Remarks
24.FAN/SOL TEST		<p>Mode for checking the operations of the following fans and solenoids. The fan or solenoid operates while the key is pressed, and stops when the key is released.</p> <p><b>NOTE</b></p> <p>The fan or solenoid will not operate if any one interlock switch is not closed.</p> <p><b>Blower fan (FAN1)</b> Operates with the [start] key.</p> <p><b>Suction fan (FAN2)</b> Operates with the [stop] key.</p> <p><b>Suction solenoid (SOL1)</b> Operates with the [test] key.</p>
25.RG.BRAKE TEST		<p>Mode for checking the operations of the registration brake. The registration brake operates while the key is pressed, and stops when the key is released.</p> <p><b>Registration brake (BRK1)</b> Operates with the [start] key.</p>
27.SIMULATION	RUN W/O PAPER*	<p>Mode for operating each mechanism without using paper.</p> <ul style="list-style-type: none"> <li>○ Simulation starts with the [start] key.</li> <li>○ Simulation stops with the [stop] key.</li> </ul>
28.ALIGNMENT		<p>Mode for making the folding stoppers of folding plates 1 and 2 parallel.</p> <p>☞ Refer to “Chapter 5 STANDARDS/ADJUSTMENTS &gt; 4.1.1 Adjusting the parallelity of the folding stopper”.</p> <p><b>NOTE</b></p> <p>The folding stopper will not operate if any one interlock switch is not closed.</p>

Maintenance menu (1st line display)	Setting (2nd line display)	Contents/Remarks
31.CHK SENSOR SW	ABCDEFGHIJKLMN*P*	<p>Mode for checking the status of each sensor and switch. When a sensor or switch is turned ON/OFF, the corresponding display changes and the buzzer sounds.</p> <p><b>Display of ON state;</b> Displayed in alphabets at the bottom of the LCD: A : Paper feed inlet sensor (PS10) B : Paper ejection outlet sensor (PS12) C : Paper sensor (PS8) D : Stacker roller home sensor (PS11) E : Folding plate 1 home sensor (PS3) F : Folding plate 2 home sensor (PS6) G : Paper feed tray sensor 2 (PS9) H : Paper feed tray home switch (SW4) I : Top cover R switch (SW1) J : Top cover L switch (SW5) K : Side cover switch (SW2) L : Folding plate switch (SW3) M : Paper feed tray upper limit switch (SW6) N : Paper feed tray sensor 1 (PS7) O : Tray down button (SW8) P : Safety lever switch (SW7)</p> <p><b>Display of OFF state;</b> Displayed as “-” at the bottom of the LCD.</p>
32.CHK SIZE SNSR	--■---	<p>Mode for checking the operations of the PS P.W.B. unit (paper size sensor). The display changes when the side guide moves and the buzzer sounds. The sensor state is displayed as follows at the bottom of the LCD.</p> <p><b>■ displayed;</b> Sensor which is ON.</p> <p><b>[-] displayed;</b> Sensor which is OFF.</p> <p><b>Available paper sizes for UK model (from left);</b> B6, A5, B5, A4, B4, A3</p> <p><b>Available paper sizes for USA model (from left);</b> INV, STMT, LTR, LGR, LGL</p>

### 3 MENUS AND FUNCTIONS

Maintenance menu (1st line display)	Setting (2nd line display)	Contents/Remarks
33.MAIN MTR INDX	0000*	<p>Mode for checking the index sensor inside the main motor.</p> <p>When the main motor shaft is rotated (by rotating the jam correction knob or center press roller), the number of pulses is counted up and displayed at the bottom of the LCD.</p> <p>When the main motor shaft is rotated once, the number of pulses added is "15".</p> <p><b>NOTE</b></p> <ul style="list-style-type: none"> <li>● The number of pulses displayed is reset to "0" when the power is turned OFF.</li> <li>● The number of pulses is counted up even if the main motor shaft is rotated in the normal or reverse directions.</li> </ul>
34.THIN KEY CHK	ON OFF	Mode for displaying the status of thin paper feed button (SW9).
36.PANEL CHECK		<p>Mode for checking the LEDs and 7-segment of the control panel.</p> <ul style="list-style-type: none"> <li>○ [Start] key The whole 7-segment lights up.</li> <li>○ [Stop] key All the LEDs light up.</li> </ul>

## 3.2 Other Functions

### 3.2.1 Setting the paper feed tray sensor 2 (PS9) to OFF

#### a. Outline

When the paper feed tray sensor 2 (PS9) is malfunctioning, as an emergency measure, the detection function can be set to OFF (disabled) in the use of this unit.

If required, explain the following procedure to users.

#### Reference

When the paper feed tray sensor 2 (PS9) is disabled, the paper feed tray sensor 1 (PS7) will perform substitute control.

For this reason, the up/down operations of the paper feed tray will become slower than normally, and the overall processing speed will drop.

#### b. Operations

- 1) Turn ON the power switch while pressing the [stop] and [mode] keys.

#### NOTE

This setting is cleared when the power switch is turned OFF.

## 4 UPGRADING THE PROGRAM VERSION

### 4.1 Outline

The version of the program of the MC unit can be upgraded.

To upgrade the version, prepare an EPROM written with the program of the new version.

#### 4.1.1 Preparing the rewriting tool (EPROM)

Write the program in the EPROM and create the rewriting tool.

Program name	EPROM type No.
12T-8xxxx.mot	Equivalent to STMicroelectronics M27C1001-12F1

### 4.2 Upgrading the Version

#### 4.2.1 Upgrading the program version

- 1) Turn OFF the power switch.
- 2) Attach the rewriting tool (EPROM) to the IC socket (U11) on the MC unit.
- 3) Enter the maintenance mode.  
While pressing the [start] key and [stop] key, turn ON the power.
- 4) Select "18. PROG VER UP".  
Enter "18" using the numerical keys, and press the [folding mode] key.
- 5) Press the [start] key and start rewriting.  
The time required for rewriting is about 20 seconds.  
When rewriting ends normally, the new version program starts automatically.

#### NOTE

- During rewriting, never turn OFF the power.
  - During rewriting, all key operations will be disabled. Nothing will be displayed on the LCD.
  - If the buzzer sounds "pi.pi.pi" when the [start] key is pressed, it indicates the ID error of the program. The following reasons are possible.
    - The EPROM is not inserted in the socket correctly
    - The program is not written in the EPROM correctly.
    - A program with a different ID is written in the EPROM.
- 
- 6) Enter the maintenance mode, select "15. MC ROM VER", and check that the new version is displayed on the LCD.
  - 7) Turn OFF the power, and remove the EPROM.

## 5 DATA INITIALIZATION

### 5.1 Erasing Standard Folding Correction/Custom Folding Data

Standard folding correction registration and custom folding registration data only can be collectively erased by the following procedure.

- 1) Turn OFF the power switch.
- 2) While pressing the [test] key, turn ON the power switch.

### 5.2 Initializing the EEPROM

If the setting data in the EEPROM (U1) is lost due to some reason, the display will not function normally.

In this case, initialize the EEPROM (U1) by the following procedure.

#### a. Procedure for initializing with current total count remaining

- 1) Turn OFF the power switch.
- 2) While pressing the [start] key, [stop] key, and [test] key together, turn ON the power switch. The initialization of the EEPROM (U1) starts, and when it ends, the buzzer sounds three times. This indicates initialization of all data except the total count registered in the EEPROM (U1).
- 3) While checking the "BACKUP DATA FORM" pasted inside cover F, register each setting data.

---

#### NOTE

The following procedure erases total count important for the maintenance of the unit. Therefore it should never be performed unless failures which cannot be resolved by the above procedure have occurred.

Procedure for initializing total count at the same time

- 1) Turn OFF the power switch.
  - 2) While pressing the [start] key, [stop] key, and [clear] key together, turn ON the power switch. All data in the EEPROM (U1) including the total count is initialized.
-

---

# *Chapter 7*

# **TROUBLESHOOTING**

---

# 1 OUTLINE

The problems of this unit can broadly be divided into the following three types.

### 1. Abnormal processing results

The unit operates but the desired processing results cannot be obtained.

Example;

- Mis-feed
- Double-feed
- Folding misalignment

If these phenomena occur, refer to the following and perform the appropriate measure.

☞ Refer to "2 TROUBLESHOOTING BY PHENOMENON".

### 2. Operational problems (Error message is displayed on the control panel)

The following four types of messages are displayed on the control panel.

Message type;

- Paper jam message
- Error message
- Trouble message
- Other messages (No paper, cover open, etc.)

If these messages are displayed, refer to the following and perform the appropriate measure.

☞ Refer to "3 TROUBLESHOOTING BY MESSAGE DISPLAYED".

### 3. Operational problems (No error message is displayed on the control panel)

Example;

- Power does not turn ON
- Nothing is displayed on control panel
- Key operations are disabled

If these phenomena occur, refer to the following and perform the appropriate measure.

☞ Refer to "4 TROUBLESHOOTING FOR OPERATION FAILURES".



## 2 TROUBLESHOOTING BY PHENOMENON

### 2.1 Paper Feed Problems

#### 2.1.1 Mis-feed

- 1) Is the separating air too weak?  
**Yes:** Increase the separating air using the separating air adjusting knob.

---
- 2) Is the separator height too high?  
**Yes:** Lower the separator using the separator adjusting knob.

---
- 3) Is the level sensor height too low?  
**Yes:** Raise the level sensor using the level sensor adjusting lever.

---
- 4) Is the suction belt dirty or are there foreign particles on it?  
**Yes:** Clean the suction belt.  
If it cannot be cleaned properly, or it is damaged, replace the suction belt.

---
- 5) Are abnormal sounds produced from the suction conveyor?  
**Yes:** Check the rotating portion of the suction conveyor and if abnormal, replace it.

---

#### 2.1.2 Continuous-feed

- 1) Is the separating air too strong?  
**Yes:** Weaken the separating air using the separating air adjusting knob.

---
- 2) Is the separator height too low?  
**Yes:** Raise the separator using the separator adjusting knob.

---
- 3) Is the level sensor height too high?  
**Yes:** Lower the level sensor using the level sensor adjusting lever.

---

### 2.2 Folding Problems

#### 2.2.1 Folding misalignment along vertical length of paper

- 1) Was the processing speed changed halfway through?  
**Yes:** Set back the previous speed.  
If the speed has been changed, the folding stopper position must be corrected.

---
  - 2) Was the paper type (paper quality, thickness) changed halfway through?  
**Yes:** Use the original paper before change.  
If paper has been changed, the folding stopper position must be corrected.

---
- No:** Adjust each part according to the basic adjustment procedure.  
 Refer to "Chapter 5 STANDARDS/ADJUSTMENTS > 1 BASIC ADJUSTMENT PROCEDURES".

---

### 2.2.2 Folding misalignment along sides of paper

- 1) Is there clearance between the side guides and paper?  
**Yes:** Align paper neatly and stack, then push the side guides lightly against the paper.

---

- 2) Is the side guide adjusting knob loose?  
**Yes:** Tighten the knob firmly.

---

- 3) Is the paper trimmed precisely?  
**No:** If the trimming misalignment of the paper lead edge is large, it cannot be corrected using the side guide adjusting knob and skew correction knob alone.  
Have the user use paper with little trimming misalignment.

---

- 4) Are the left and right skew roller spring pressure adjusting knobs set at the same position?  
**No:** Set at the same position.

---

- 5) Is the folding roller dirty?  
**Yes:** Clean with a cloth moistened with alcohol.

---

- 6) Is the registration brake (BRK1) normal?  
☞ Refer to "Chapter 6 MAINTENANCE MODE > 3.1 Menu List".  
If the registration brake (BRK1) does not operate, folding misalignment may have occurred along the sides of the paper.  
Remove the main cover F and check the operations of the registration brake (BRK1).  
**No:** Check the connection of connectors and if bundled wires have disconnected or short-circuited, and if they are found to be normal, replace the brake.

---

- Yes:** Replace the MC unit.

---

### 2.2.3 When paper is not folded at the normal position

- 1) Is folding plate set properly?  
**No:** Set the folding plate properly.

---

- 2) Has static electricity occurred in the paper?  
**Yes:** Fan the paper well, and decrease the processing speed.

---

- 3) Is non-standard paper with the same width but different length from standard paper used?  
For USA model, when stacking 8.5" × 11" (LTR) size paper on the paper feed tray, if the rear guide, etc. is pressing against the legal paper detection sensor (PS13), the paper will be incorrectly detected as 8.5" × 14" (LGL) size paper.  
**Yes:** Follow the procedure for non-standard paper.

---

- 4) Are the left and right skew roller spring pressure adjusting knobs set at the same position?  
**No:** Set at the same position.

---

- Yes:** Adjust each part according to the basic adjustment procedure.  
☞ Refer to "Chapter 5 STANDARDS/ADJUSTMENTS > 1 BASIC ADJUSTMENT PROCEDURES".

---

## 3 TROUBLESHOOTING BY MESSAGE DISPLAYED

### 3.1 Paper Jam Messages

#### 3.1.1 When “JAM FEED SECT” is displayed

- 1) Are there foreign particles such as paper dusts and paper chips sticking to the light-receiving/light-emitting sensors of the paper feed inlet sensor (PS10)?

**Yes:** Clean the sensors to remove the paper dusts and paper chips.

---

- 2) Is the paper feed inlet sensor (PS10) normal?

☞ Refer to “Chapter 6 MAINTENANCE MODE > 3.1 Menu List”.

**No:** Check the optical axis, connection of connectors and if bundled wires have disconnected or short-circuited, and if they are found to be normal, replace the sensor.

---

- 3) Is the registration clutch (CLH3) normal?

☞ Refer to “Chapter 6 MAINTENANCE MODE > 3.1 Menu List”.

**No:** Check the connection of connectors and if bundled wires have disconnected or short-circuited, and if they are found to be normal, replace the clutch.

---

**Yes:** Replace the MC unit.

---

#### 3.1.2 When “JAM INSIDE” is displayed

- 1) Is the paper ejection outlet sensor (PS12) normal?

☞ Refer to “Chapter 6 MAINTENANCE MODE > 3.1 Menu List”.

**No:** Check the optical axis, connection of connectors and if bundled wires have disconnected or short-circuited, and if they are found to be normal, replace the sensor.

---

- 2) Is the registration clutch (CLH3) normal?

☞ Refer to “Chapter 6 MAINTENANCE MODE > 3.1 Menu List”.

**No:** Check the connection of connectors and if bundled wires have disconnected or short-circuited, and if they are found to be normal, replace the clutch.

---

**Yes:** Replace the MC unit.

---

#### 3.1.3 When “JAM EXIT” is displayed

- 1) Are there foreign particles such as paper dusts and paper chips sticking to the light-receiving/light-emitting sensors of the paper ejection outlet sensor (PS12)?

**Yes:** Clean the sensors to remove the paper dusts and paper chips.

---

- 2) Is the paper ejection outlet sensor (PS12) normal?

☞ Refer to “Chapter 6 MAINTENANCE MODE > 3.1 Menu List”.

**No:** Check the optical axis, connection of connectors and if bundled wires have disconnected or short-circuited, and if they are found to be normal, replace the sensor.

---

**Yes:** Replace the MC unit.

---

## 3.2 Error Messages

### 3.2.1 When “F.PLATE SET ERR” is displayed

1) Is the folding plate switch (SW3) normal?

☞ Refer to “Chapter 6 MAINTENANCE MODE > 3.1 Menu List”.

**No:** Check the connection of connectors and if bundled wires have disconnected or short-circuited, and if they are found to be normal, replace the switch.

---

**Yes:** Replace the MC unit.

---

### 3.2.2 When “FEED ERROR” is displayed

1) Check “2.1.1 Mis-feed” first.

2) Is the paper feed inlet sensor (PS10) normal?

☞ Refer to “Chapter 6 MAINTENANCE MODE > 3.1 Menu List”.

**No:** Check the optical axis, connection of connectors and if bundled wires have disconnected or short-circuited, and if they are found to be normal, replace the sensor.

---

3) Is the paper feed clutch (CLH1) normal?

☞ Refer to “Chapter 6 MAINTENANCE MODE > 3.1 Menu List”.

**No:** Check the connection of connectors and if bundled wires have disconnected or short-circuited, and if they are found to be normal, replace the clutch.

---

4) Is the blower fan (FAN1) or suction fan (FAN2) normal?

☞ Refer to “Chapter 6 MAINTENANCE MODE > 3.1 Menu List”.

**No:** Check the connection of connectors and if bundled wires have disconnected or short-circuited, and if they are found to be normal, replace the fan.

---

5) Is the suction solenoid (SOL1) normal?

☞ Refer to “Chapter 6 MAINTENANCE MODE > 3.1 Menu List”.

**No:** Check the connection of connectors and if bundled wires have disconnected or short-circuited, and if they are found to be normal, replace the solenoid.

---

**Yes:** Replace the MC unit.

---

## 3.3 Trouble Messages

### 3.3.1 When “MOTOR ERROR 1” is displayed

1) Is the main motor (MOT1) normal?

☞ Refer to “Chapter 6 MAINTENANCE MODE > 3.1 Menu List”.

**No:** Check the connection of connectors and if bundled wires have disconnected or short-circuited, and if they are found to be normal, replace the motor.

---

**Yes:** Replace the MC unit.

---

### 3.3.2 When “MOTOR ERROR 4” is displayed

1) Has the folding plate 1 folding stopper locked?

**Yes:** Rotate the screw shaft unit with a flat screwdriver, etc. to release the lock.

If the folding stopper has locked, the index sensor may very likely be malfunctioned, so replace folding plate 1 index sensors A (PS1) and B (PS2).

---

2) Is the folding plate 1 home sensor (PS3) normal?

☞ Refer to “Chapter 6 MAINTENANCE MODE > 3.1 Menu List”.

**No:** Check the connection of connectors and if bundled wires have disconnected or short-circuited, and if they are found to be normal, replace the sensor.

---

3) Is the folding plate 1 stopper motor (MOT2) normal?

☞ Refer to “Chapter 6 MAINTENANCE MODE > 3.1 Menu List”.

**No:** Check the connection of connectors and if bundled wires have disconnected or short-circuited, and if they are found to be normal, replace the motor.

---

4) Is the problem resolved by replacing the folding plate 1 index sensor A (PS1) or B (PS2)?

**Yes:** End.

---

**No:** Check the connection of connectors and if bundled wires have disconnected or short-circuited, and if they are found to be normal, replace the MC unit.

---

### 3.3.3 When “MOTOR ERROR 5” is displayed

1) Has the folding plate 2 folding stopper locked?

**Yes:** Rotate the screw shaft unit with a flat screwdriver, etc. to release the lock.

If the folding stopper has locked, the index sensor may very likely be malfunctioned, so replace folding plate 2 index sensors A (PS4) and B (PS5).

---

2) Is the folding plate 2 home sensor (PS6) normal?

☞ Refer to “Chapter 6 MAINTENANCE MODE > 3.1 Menu List”.

**No:** Check the connection of connectors and if bundled wires have disconnected or short-circuited, and if they are found to be normal, replace the sensor.

---

3) Is the folding plate 2 stopper motor (MOT3) normal?

☞ Refer to “Chapter 6 MAINTENANCE MODE > 3.1 Menu List”.

**No:** Check the connection of connectors and if bundled wires have disconnected or short-circuited, and if they are found to be normal, replace the motor.

---

4) Is the problem resolved by replacing the folding plate 2 index sensor A (PS4) or B (PS5)?

**Yes:** End.

---

**No:** Check the connection of connectors and if bundled wires have disconnected or short-circuited, and if they are found to be normal, replace the MC unit.

---

#### 3.3.4 When “MOTOR ERROR 3” is displayed

- 1) Are there foreign particles such as paper dusts and paper chips sticking to the light-receiving/light-emitting sensors of the stacker roller home sensor (PS11)?

**Yes:** Clean the sensors to remove the paper dusts and paper chips.

---

- 2) Is the stacker roller home sensor (PS11) normal?

☞ Refer to “Chapter 6 MAINTENANCE MODE > 3.1 Menu List”.

**No:** Check the connection of connectors and if bundled wires have disconnected or short-circuited, and if they are found to be normal, replace the sensor.

---

- 3) Is the stacker roller moving motor (MOT5) normal?

☞ Refer to “Chapter 6 MAINTENANCE MODE > 3.1 Menu List”.

**No:** Check the connection of connectors and if bundled wires have disconnected or short-circuited, and if they are found to be normal, replace the motor.

---

**Yes:** Replace the MC unit.

---

#### 3.3.5 When “MOTOR ERROR 2” is displayed

- 1) Is this message displayed when the paper feed tray rises?

**Yes:** Check from step 2a) onwards.

---

**No:** Check from step 2b) onwards.

---

- 2a) Is the paper feed tray sensor 1 (PS7) or 2 (PS9) normal?

☞ Refer to “Chapter 6 MAINTENANCE MODE > 3.1 Menu List”.

**No:** Check the connection of connectors and if bundled wires have disconnected or short-circuited, and if they are found to be normal, replace the sensor.

---

- 2b) Is the paper feed tray home switch (SW4) normal?

☞ Refer to “Chapter 6 MAINTENANCE MODE > 3.1 Menu List”.

**No:** Check the connection of connectors and if bundled wires have disconnected or short-circuited, and if they are found to be normal, replace the switch.

---

- 3) Is the paper feed tray motor (MOT4) normal?

☞ Refer to “Chapter 6 MAINTENANCE MODE > 3.1 Menu List”.

**No:** Check the connection of connectors and if bundled wires have disconnected or short-circuited, and if they are found to be normal, replace the motor.

---

**Yes:** Replace the MC unit.

---

#### 3.3.6 When “TRAY UP ERROR” is displayed

- 1) Are there foreign particles between the paper feed tray and suction belt?

**Yes:** Remove the foreign particles.

---

- 2) Is the stacked paper lead edge touching the shutter?

**No:** Stack the paper again.

---

- 3) Is the attaching position of the paper feed tray sensor 2 (PS9) appropriate?

 Refer to “Chapter 5 STANDARDS/ADJUSTMENTS > 3.2.6 Adjusting paper feed tray sensor 2 (PS9) position”.

**No:** Adjust.

---

- 4) Is the paper feed tray upper limit switch (SW6) normal?

 Refer to “Chapter 6 MAINTENANCE MODE > 3.1 Menu List”.

**No:** Check the connection of connectors and if bundled wires have disconnected or short-circuited, and if they are found to be normal, replace the switch.

---

**Yes:** Replace the MC unit.

---

#### 3.3.7 When “TRAY DOWN ERROR” is displayed

- 1) Are there foreign particles between the paper feed tray and safety lever?

**Yes:** Remove the foreign particles.

---

- 2) Is the attaching position of the safety lever switch (SW7) appropriate?

 Refer to “Chapter 5 STANDARDS/ADJUSTMENTS > 2.1.1 Adjusting the interlock switch position”.

**No:** Adjust.

---

- 3) Is the safety lever switch (SW7) normal?

 Refer to “Chapter 6 MAINTENANCE MODE > 3.1 Menu List”.

**No:** Check the connection of connectors and if bundled wires have disconnected or short-circuited, and if they are found to be normal, replace the switch.

---

**Yes:** Replace the MC unit.

---

## 3.4 Other Messages

### 3.4.1 When “NO PAPER” is displayed

1) Is the paper sensor (PS8) normal?

☞ Refer to “Chapter 6 MAINTENANCE MODE > 3.1 Menu List”.

**No:** Check the connection of connectors and if bundled wires have disconnected or short-circuited, and if they are found to be normal, replace the sensor.

---

**Yes:** Replace the MC unit.

---

### 3.4.2 When “TOP COVER-L OPEN” is displayed

1) Is the attaching position of the top cover L switch (SW5) appropriate?

☞ Refer to “Chapter 5 STANDARDS/ADJUSTMENTS > 2.1.1 Adjusting the interlock switch position”.

**No:** Adjust.

---

2) Is the top cover L switch (SW5) normal?

☞ Refer to “Chapter 6 MAINTENANCE MODE > 3.1 Menu List”.

**No:** Check the connection of connectors and if bundled wires have disconnected or short-circuited, and if they are found to be normal, replace the switch.

---

**Yes:** Replace the MC unit.

---

### 3.4.3 When “TOP COVER-R OPEN” is displayed

1) Is the attaching position of the top cover R switch (SW1) appropriate?

☞ Refer to “Chapter 5 STANDARDS/ADJUSTMENTS > 2.1.1 Adjusting the interlock switch position”.

**No:** Adjust.

---

2) Is the top cover R switch (SW1) normal?

☞ Refer to “Chapter 6 MAINTENANCE MODE > 3.1 Menu List”.

**No:** Check the connection of connectors and if bundled wires have disconnected or short-circuited, and if they are found to be normal, replace the switch.

---

**Yes:** Replace the MC unit.

---

### 3.4.4 When “SIDE COVER OPEN” is displayed

1) Is the attaching position of the side cover switch (SW2) appropriate?

☞ Refer to “Chapter 5 STANDARDS/ADJUSTMENTS > 2.1.1 Adjusting the interlock switch position”.

**No:** Adjust.

---

2) Is the side cover switch (SW2) normal?

☞ Refer to “Chapter 6 MAINTENANCE MODE > 3.1 Menu List”.

**No:** Check the connection of connectors and if bundled wires have disconnected or short-circuited, and if they are found to be normal, replace the switch.

---

**Yes:** Replace the MC unit.

---



## 4 TROUBLESHOOTING FOR OPERATION FAILURES

### 4.1 Power Does Not Turn ON

- 1) Is the power plug inserted into the power outlet properly?  
**No:** Insert.

---
- 2) Are the following connectors connected normally?
  - MC unit : J2
  - Switching power supply: CN1, CN51**No:** Re-connect the connectors.

---
- 3) Are the bundled wires between the connectors of step 2) disconnected or short-circuited?  
**Yes:** Replace the bundled wires.  
Check for problems in the electric parts of the part connected to and replace if faulty.

---
- 4) Is rated power supplied to the outlet?  
**No:** Explain to the user that the unit is not faulty.

---
- 5) When the power switch is turned ON, is power conducted to it?  
**No:** Replace the power switch.

---
- 6) When the power switch is turned ON, is AC power supplied to the switching power supply?  
**No:** Replace the bundled wires from the power switch to the switching power supply.  
Check for problems in the electric parts of the part connected to and replace if faulty.

---

**Yes:** Replace the switching power supply.

---

### 4.2 Nothing is Displayed on Control Panel

- 1) Check "4.1 Power Does Not Turn ON" first.
- 2) Are the following connectors connected normally?
  - MC unit : J6
  - Control panel: CN1**No:** Re-connect the connectors.

---
- 3) Are the bundled wires between the connectors of step 2) disconnected or short-circuited?  
**Yes:** Replace the bundled wires.  
Check for problems in the electric parts of the part connected to and replace if faulty.

---
- 4) Is the problem resolved by replacing the control panel?  
**Yes:** End.

---

**No:** Replace the MC unit.

---

### 4.3 Key Operations are Disabled on Control Panel

- 1) Is there any key which remains pressed?

**Yes:** Unpress it and check for key input problems.

---

- 2) Are the following connectors connected normally?

- MC unit : J6
- Control panel : CN1

**No:** Re-connect the connectors.

---

- 3) Are the bundled wires between the connectors of step 2) disconnected or short-circuited?

**Yes:** Replace the bundled wires.

Check for problems in the electric parts of the part connected to and replace if faulty.

---

- 4) Is the problem resolved by replacing the control panel?

**Yes:** End.

---

**No:** Replace the MC unit.

---

### 4.4 Misdetection of Standard Paper Sizes Occurs

- 1) Is the PS P.W.B. unit (PCB4) normal?

☞ Refer to "Chapter 6 MAINTENANCE MODE > 3.1 Menu List".

If the PS P.W.B. unit (PCB4) does not operate, the paper size may be detected as "B6" or "INV" after power ON.

For USA model, when stacking 8.5" × 11" (LTR) size paper on the paper feed tray, if the rear guide, etc. is pressing against the legal paper detection sensor (PS13), the paper will be incorrectly detected as 8.5" × 14" (LGL) size paper.

Take note that this unit does not detect PS P.W.B. unit (PCB4) problems.

**No:** Check the connection of connectors and if bundled wires have disconnected or short-circuited, and if they are found to be normal, replace the PS P.W.B. unit.

---

**Yes:** Replace the MC unit.

---

---

# *Appendix*

---

# 1 LIST OF DISPLAYED MESSAGES

## 1.1 No Paper

Message	Detection details
NO PAPER	The paper sensor (PS8) detected no paper on the paper feed tray.

## 1.2 Key Input Error

Message	Detection details
TOO SHORT	Enter value outside specifications for “Setting Non-standard Paper Length”, “Registering Custom Folding”, or “Correction Registration”.
TOO LONG	
OUT OF CORRECT	

## 1.3 Cover Open

Message	Detection details
TOP COVER-L OPEN	The top cover L switch (SW5) detected that the top cover L is open.
TOP COVER-R OPEN	The top cover R switch (SW1) detected that the top cover R is open.
SIDE COVER OPEN	The side cover switch (SW2) detected that the side cover is open.

## 1.4 Paper Jam/Error

Message	Detection details
F.PLATE SET ERR	The folding plate switch (SW3) cannot detect the folding plate.
FEED ERROR	<b>Mis-feed</b> The paper feed inlet sensor (PS10) does not detect the paper lead edge even after some time from the ON of the paper feed clutch (CLH1).
JAM FEED SECT	<b>Continuous-feed</b> The paper feed inlet sensor (PS10) does not detect the paper trail edge even after “paper size set + certain time” after the sensor detected the paper lead edge. <b>Paper feed section paper jam</b> The paper feed inlet sensor (PS10) does not detect the paper trail edge even after some time from the detection of continuous-feed.
JAM INSIDE	The paper ejection outlet sensor (PS12) does not detect the paper lead edge within a certain period of time (*1) after detection of the paper lead edge by the paper feed inlet sensor (PS10).
JAM EXIT	The paper ejection outlet sensor (PS12) does not detect the paper trail edge even after “finished size + certain time” after the sensor detected the paper lead edge.

\*1 : Calculated from conveyance distance inside the unit.

The conveyance distance inside the unit changes according to the positions of the folding stoppers.

## 1.5 Trouble

Message	Detection details
<b>MOTOR ERROR 1</b>	The index sensor in the main motor cannot detect the main motor (MOT1) rotation.
<b>MOTOR ERROR 4</b>	The folding plate 1 index sensor A (PS1), folding plate 1 index sensor B (PS2) cannot detect the rotation of the folding plate 1 stopper motor (MOT2).
<b>MOTOR ERROR 5</b>	The folding plate 2 index sensor A (PS4), folding plate 2 index sensor B (PS5) cannot detect the rotation of the folding plate 2 stopper motor (MOT3).
<b>MOTOR ERROR 3</b>	During detection of the stacker roller home position, the stacker roller home sensor (PS11) does not turn ON within the specified time.
	While the stacker roller is moving, the stacker roller home sensor (PS11) does not turn OFF within the specified time.
<b>MOTOR ERROR 2</b>	While the paper feed tray is rising, the paper feed tray sensor 1 (PS7) and paper feed tray sensor 2 (PS9) do not turn ON within the specified time.
	While the paper feed tray is descending, the paper feed tray home switch (SW4) does not turn ON within the specified time.
<b>TRAY UP ERROR</b>	The paper feed tray upper limit switch (SW6) turns ON.
<b>TRAY DOWN ERROR</b>	The safety lever switch (SW7) turns ON.

## 2 LAYOUT OF ELECTRICAL PARTS

### 2.1 Front of Unit

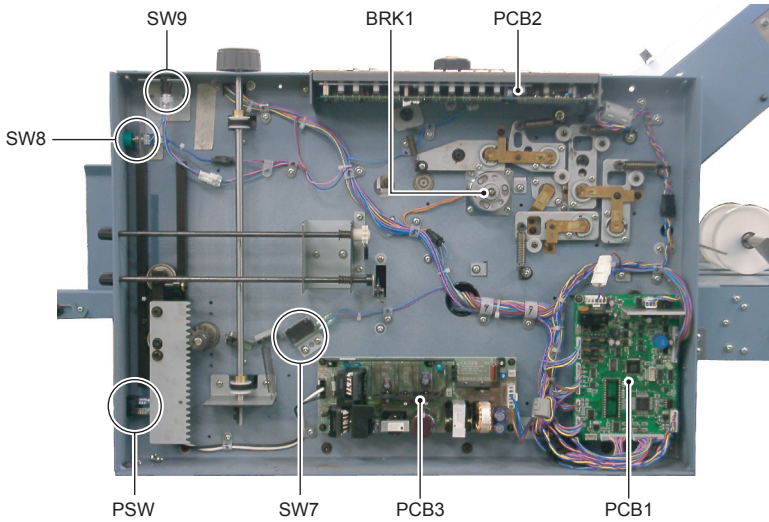

Symbol	Name	Remarks
BRK1	Registration brake	
PCB1	MC unit	
PCB2	Control panel	
PCB3	Switching power supply	
PSW	Power switch	
SW7	Safety lever switch	Safety function parts
SW8	Tray down button	
SW9	Thin paper feed button (Suction solenoid switch)	

## 2.2 Back of Unit

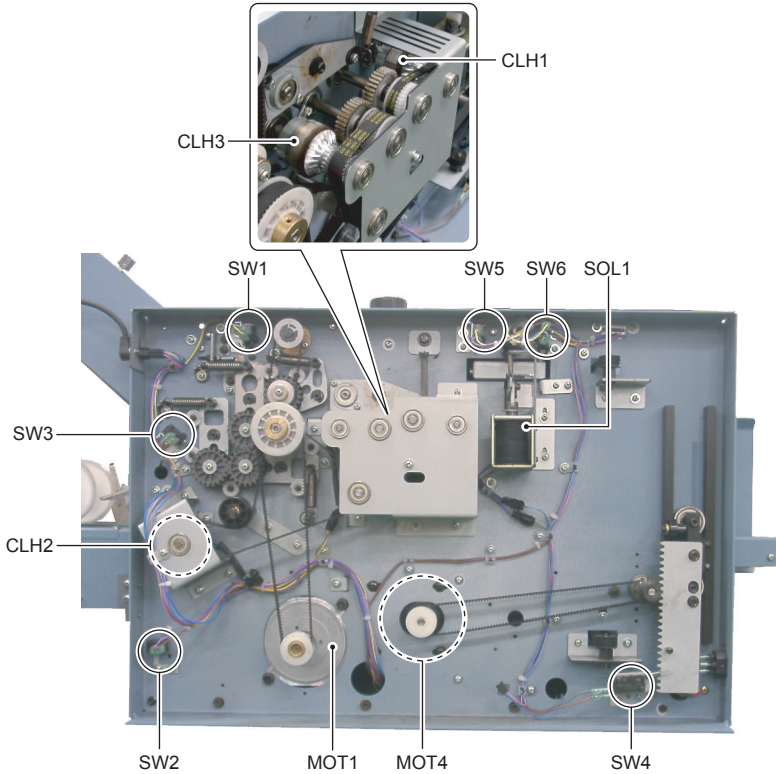

Symbol	Name	Remarks
MOT1	Main motor	
MOT4	Paper feed tray motor	
CLH1	Paper feed clutch	
CLH2	Stacker belt clutch	
CLH3	Registration clutch	
SOL1	Suction solenoid	
SW1	Top cover R switch	Safety function parts
SW2	Side cover switch	Safety function parts
SW3	Folding plate switch	Safety function parts
SW4	Paper feed tray home switch	
SW5	Top cover L switch	Safety function parts
SW6	Paper feed tray upper limit switch	Safety function parts

2.3 Inside Unit

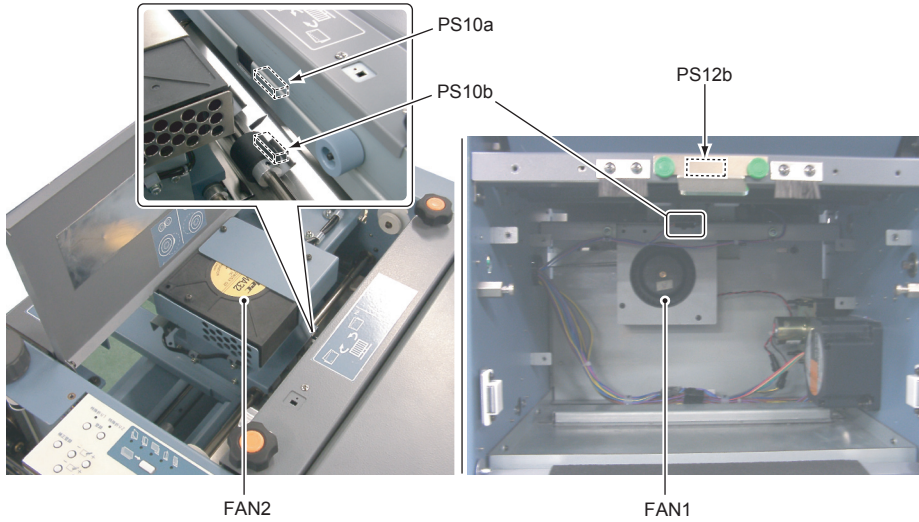

Symbol	Name	Remarks
FAN1	Blower fan	
FAN2	Suction fan	
PS10a	Paper feed inlet sensor	Light-emitting side
PS10b	Paper feed inlet sensor	Light-receiving side
PS12b	Paper ejection outlet sensor	Light-receiving side



## 2.4 Paper Feed Section

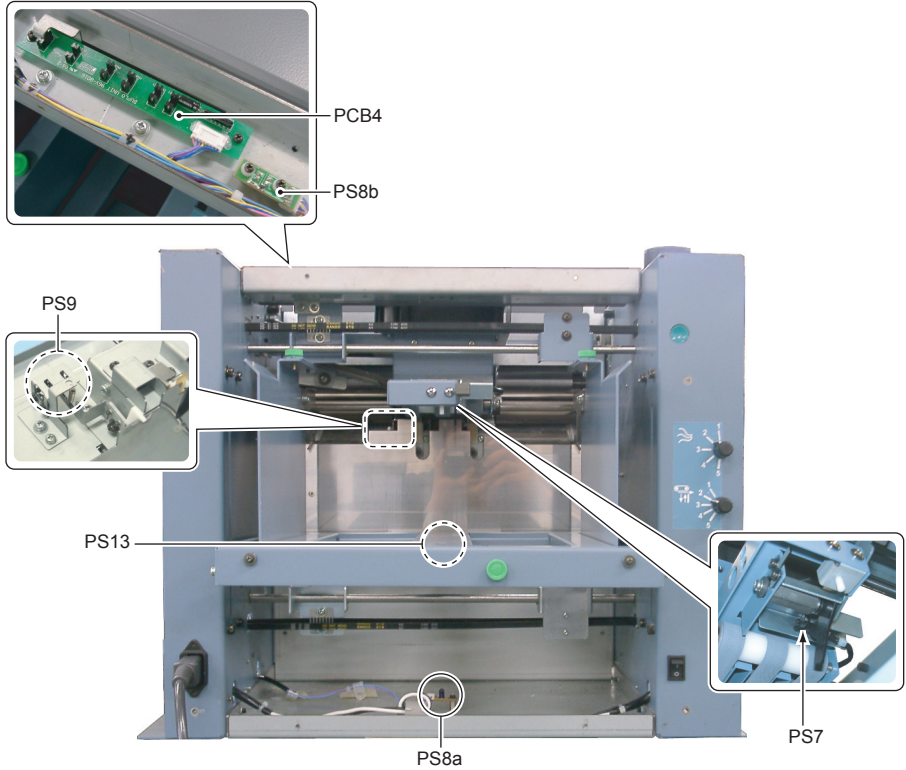

Symbol	Name	Remarks
PCB4	PS P.W.B. unit	Parts differ between UK model and USA model
PS7	Paper feed tray sensor 1	
PS8a	Paper sensor	Light-emitting side
PS8b	Paper sensor	Light-receiving side
PS9	Paper feed tray sensor 2	
PS13	Legal paper detection sensor	USA model only

### 2.5 Folding Plate Section

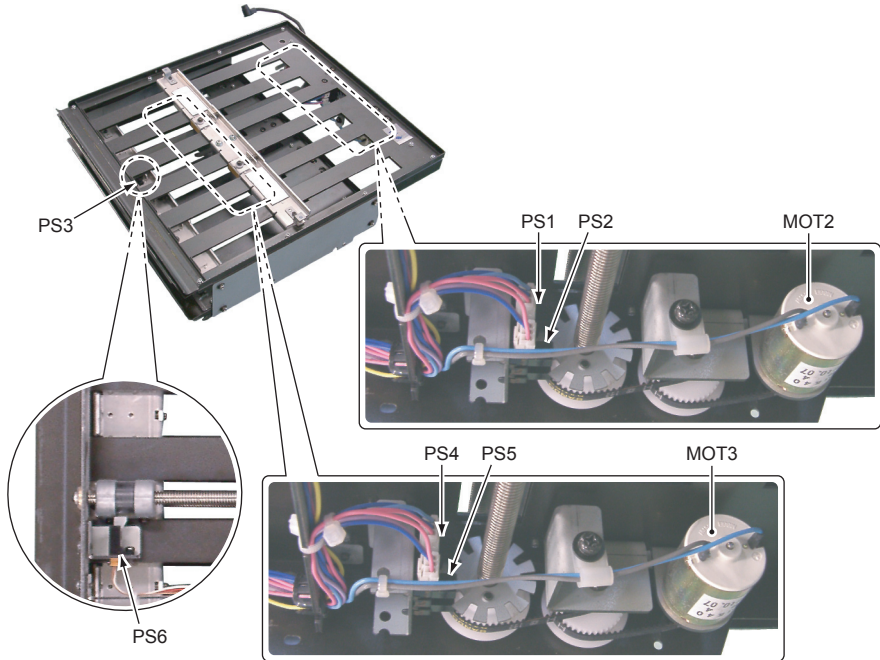

Symbol	Name	Remarks
MOT2	Folding plate 1 stopper motor	
MOT3	Folding plate 2 stopper motor	
PS1	Folding plate 1 index sensor A	
PS2	Folding plate 1 index sensor B	
PS3	Folding plate 1 home sensor	
PS4	Folding plate 2 index sensor A	
PS5	Folding plate 2 index sensor B	
PS6	Folding plate 2 home sensor	

## 2.6 Paper Ejection Section

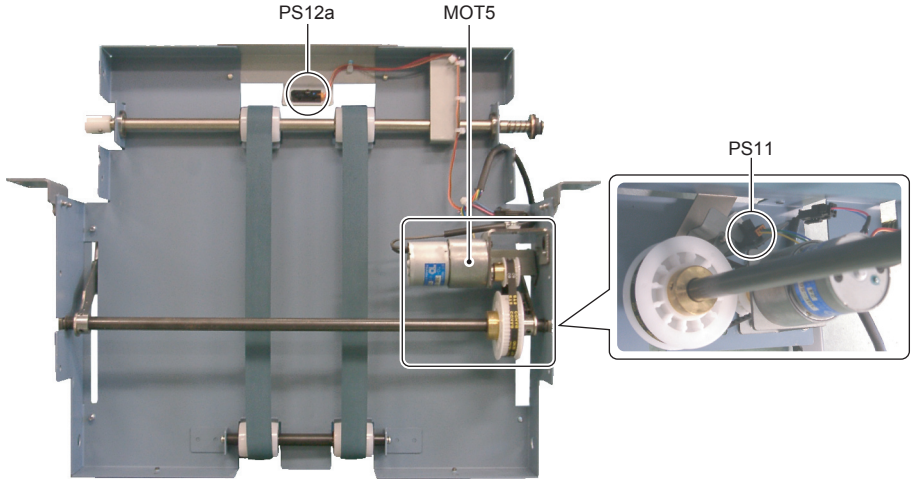

Symbol	Name	Remarks
MOT5	Stacker roller moving motor	
PS11	Stacker roller home sensor	
PS12a	Paper ejection outlet sensor	Light-emitting side



### 3.2 Control Panel

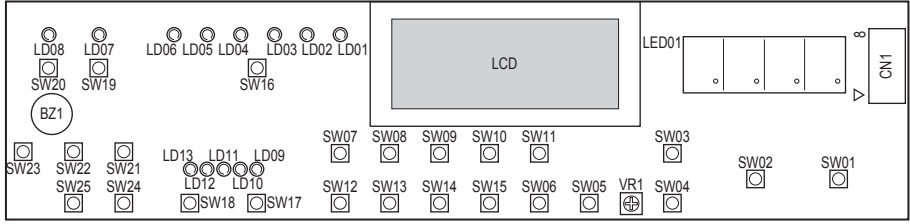

### 3.3 Switching Power Supply

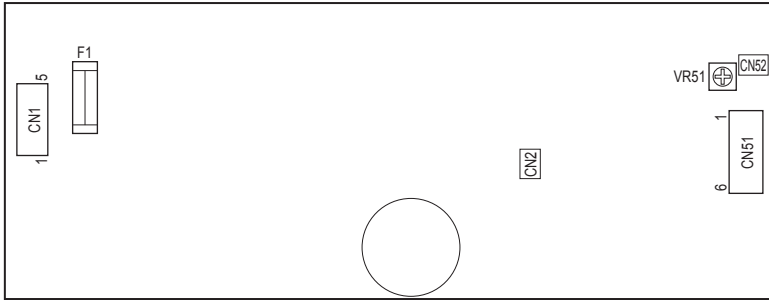

### 3.4 PS P.W.B. Unit

#### a. UK model

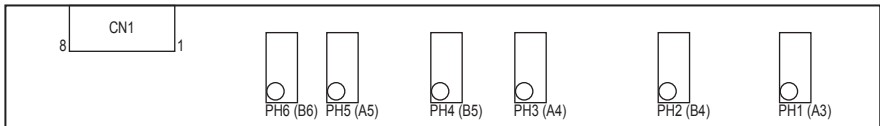

#### b. USA model

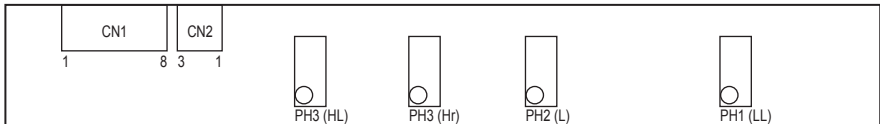

# Memo







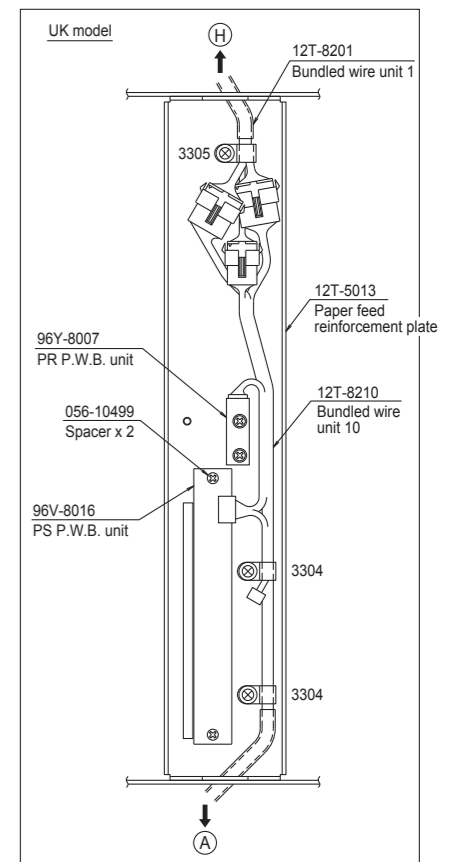
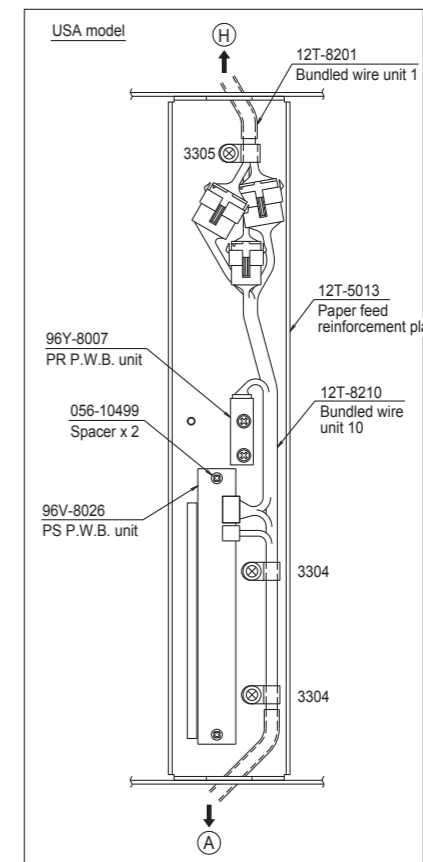
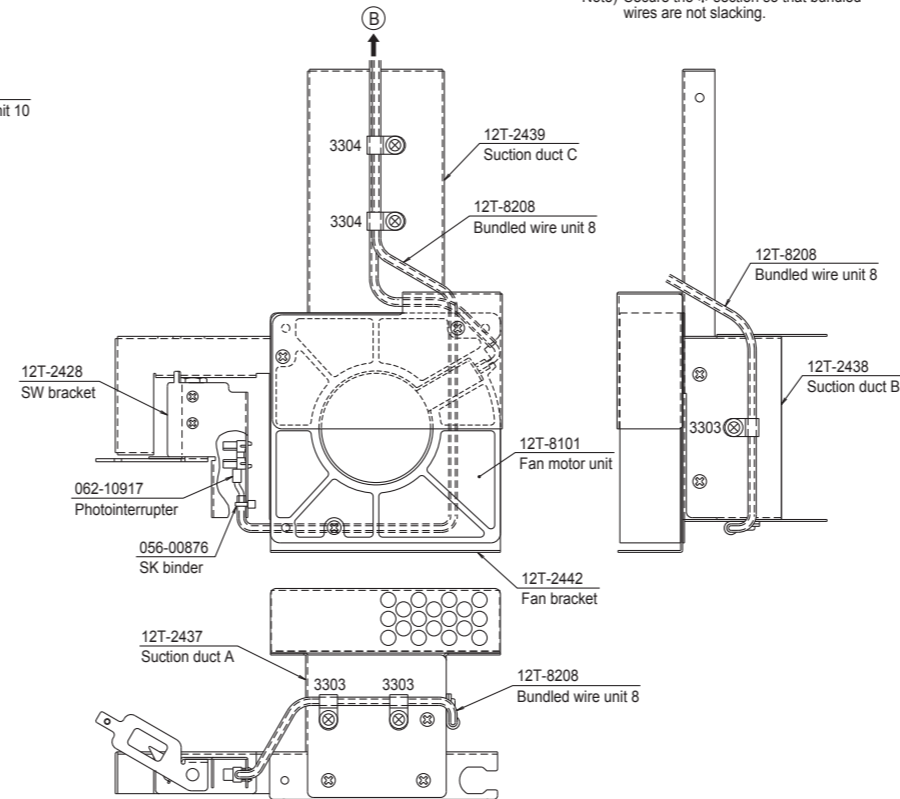
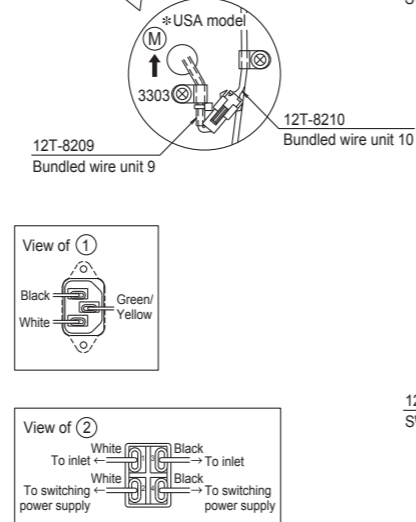
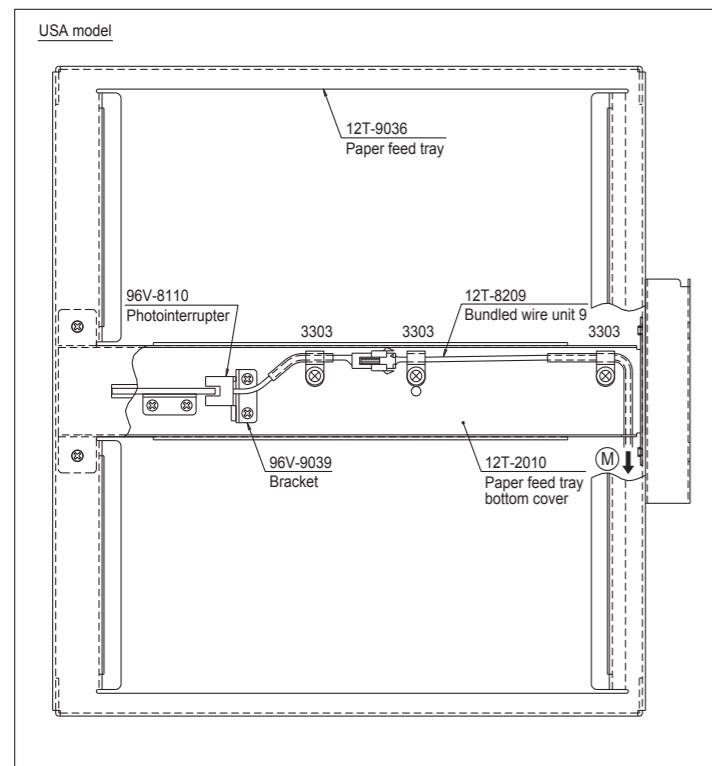
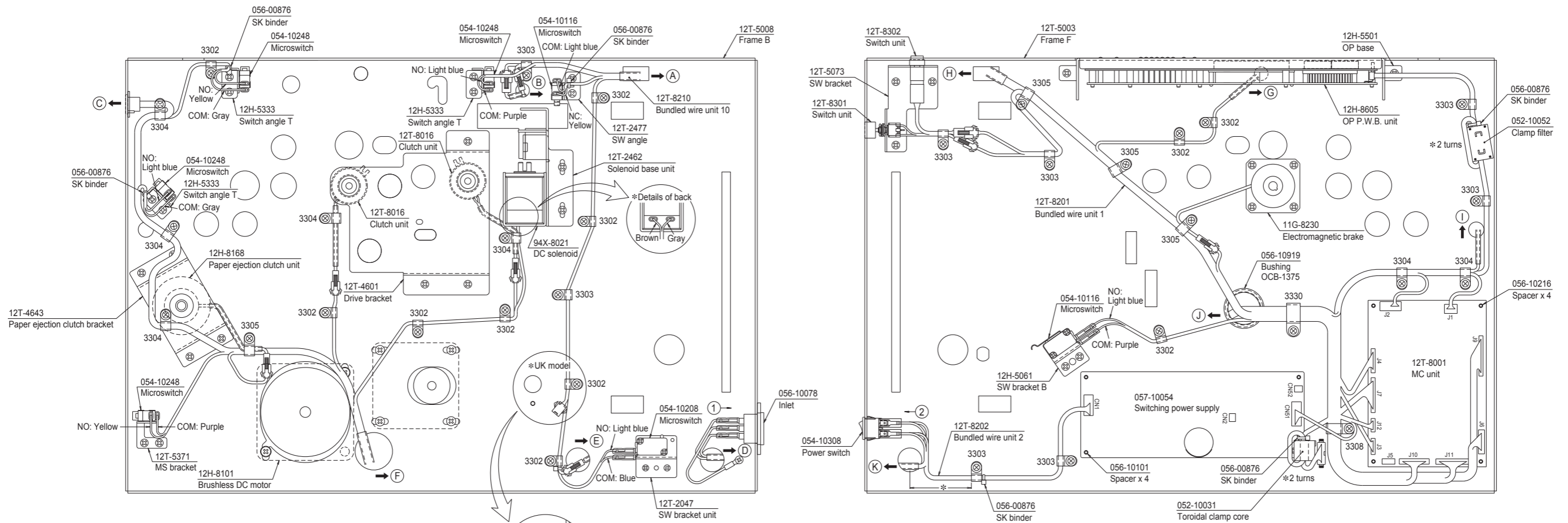

Note) Secure the \* section so that bundled wires are not slacking.

Cable clamp	
056-09001	3302
056-09002	3303
056-09003	3304
056-09004	3305
056-09006	3307
056-09007	3308
056-09009	3330

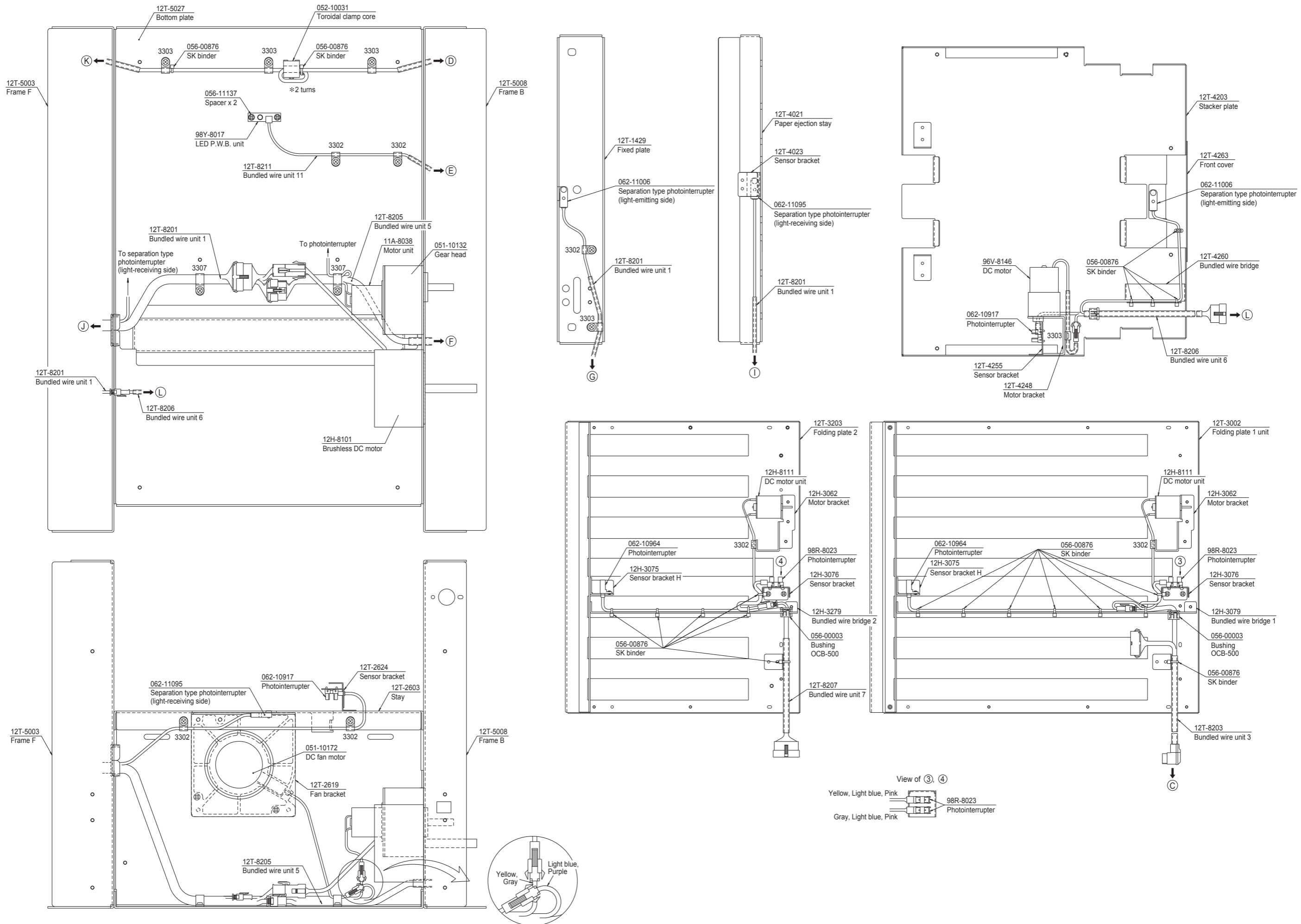

**DUPLO CORPORATION**

Duplo building, 1-6, Oyama 4 chome, Sagamihara,  
Kanagawa 229-1180, Japan

Revision 0  
(Feb. 2006)

# Duplo

12T-M12M0

DUPLO DF-1000 12T-M12M0-0602-0