

RHIN-



-TUFF

**INSTRUCTION
BOOK
FOR THE
OD 4000,
OD 3500
AND
BINDING
MODULES**

OD 4000



OD 3500

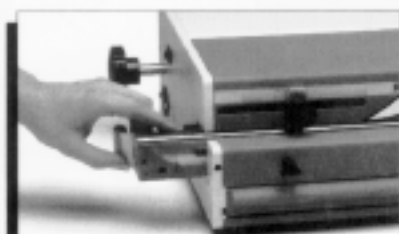
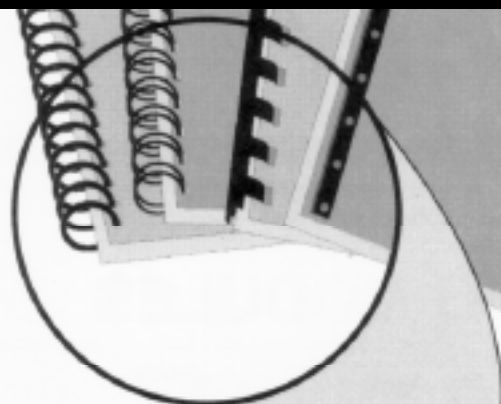
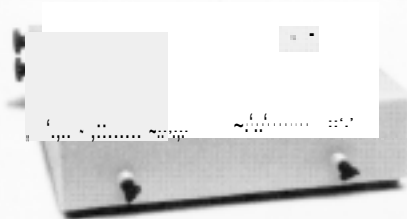

**EASILY REMOVABLE DIES
FOR YOUR BINDING NEEDS**



OD 4000 W/BINDING MODULES



OD 4000 PUNCH

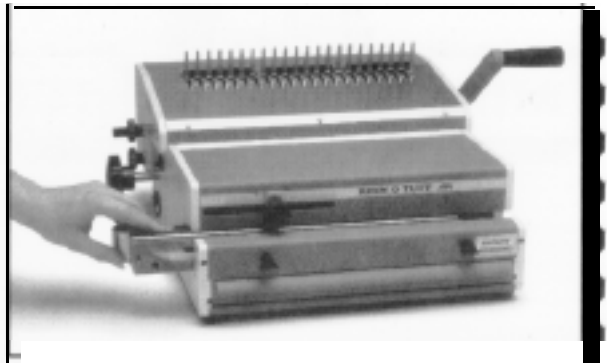

OD 4000 PUNCH WITH COMB OPENER

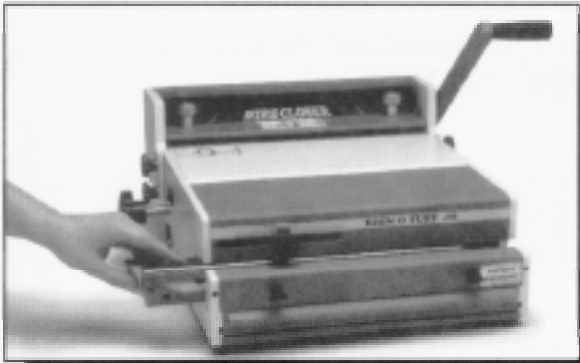

OD 4000 PUNCH WITH WIRE CLOSER



*OD 4000 PUNCH WITH WIRE CLOSER
AND COIL INSERTER*

OD 3500 W/BINDING MODULES

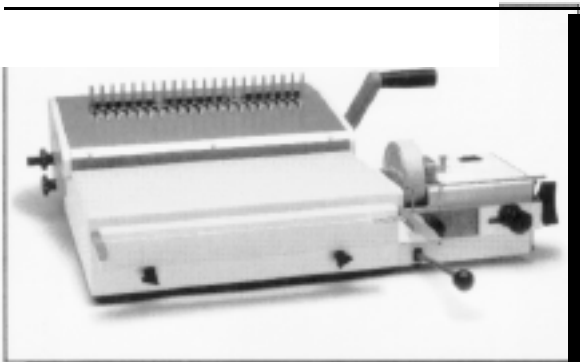

*OD 3500 COMBO BINDING STATION WITH
COMB OPENER AND COIL INSERTER*

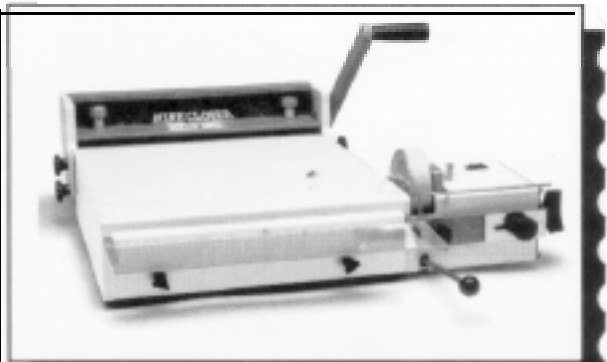

*OD 3500 COMBO BINDING STATION WITH
WIRE CLOSER AND COIL INSERTER*

OD 4000 PUNCH and OD 3500 COMBO BINDING STATION Setup & Operator Manual

**Issue 2 April, 99
Performance Design Inc.**

The Office Duty (OD 4000) electric punch, shown on opposite page, has been designed to punch most any job that may pass through your office. No matter what type of binding you need to carry out, the OD 4000 can punch the job. It will punch up to 17 sheets of 20lb (80gsm) copy paper at one time while maintaining perfect alignment. The maximum punching length is 11" or A4 European format. Any sheet smaller can be punched for the minimum size.

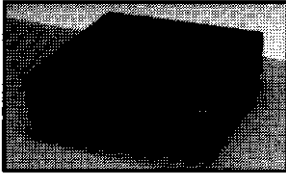

Combo Binding Station

The Combo Binding Station is a base unit that supports three different binding modules. Each module attaches in a matter of minutes. The attachment procedure will be located in the module instructional section of this manual.

There are three optional attachments (modules) for the OD 4000 Punch and OD 3500 Combo Binding Station.

These are:

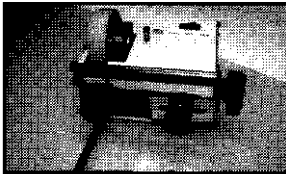

Coil Inserter

The plastic spiral inserter will bind books up to **1-1/8"** (28.6mm) thick using coil diameter up to **1-1/4"** (30mm). The unit attaches to the right side of the Combo Binding Station or OD 4000 Punch using two wing nuts for easy installation.

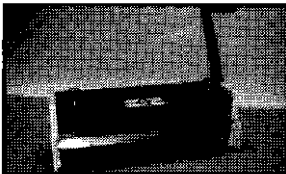

Wire C/oser

The wire closer is capable of binding books up to **1-1/8"** (28.6mm) thick. It uses wire sizes from **3/16"** to **1-1/4"**. It has an adjustable closing bar for the different size wires. Each end can be adjusted independently to obtain a perfect close. The unit attaches to the rear of the Combo Binding Station or OD 4000 Punch using four knobs.

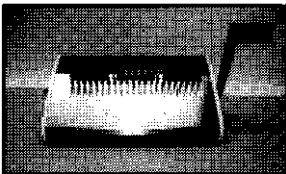

Comb Opener

The comb opener will bind books up to **2"** (51 mm) thick. The opener has an adjustable ring opener control for exact book placement. The unit attaches to the rear of the Combo Binding Station or OD 4000 Punch using four knobs.

All of the above modules can be ordered when ordering the OD 4000 Punch or the OD 3500 Combo Binding Station. Individual units can also be ordered at a latter date. Each unit can be installed in a matter of minutes. The coil inserter can be attached and kept on the machine permanently. If the Wire closer module is installed on the machine and the comb opener module is required; the wire closer will have to be removed so that the comb opener can be installed. The opposite is also true. It only takes a few minutes to detach any one of the modules to install any other one.

Table of Contents

OD 4000 PUNCH

Topic:	Page Number:
1) Important safety notices	3
2) Placing your machine in the proper location	4
3) Providing power to the machine	4
4) Die installation	4
+ Removing punch pins	4
+ Die maintenance	5
5) Setting the paper guide	5
6) Punching paper	6
7) Removing paper waste	6
8) Paper jam (Reverse knob)	6

Optional Modules & Accessories

9) Attaching Coil Inserter module	11
Setup Instructions	
a) Determine the correct size coil	12
b) Determine the correct size mandrel	12
c) Installing the mandrel on the machine	12
d) Adjusting the Mandrel bracket	12
e) Adjusting the paper stop	13
f) Adjusting the front table / lexan guide	13
g) Forward / off / reverse switch	14
h) Inserting a coil	14
i) Drive wheel stop screw	15
j) Cutting a coil	15
10) Attaching Wire Closer module	18
Setup Instructions	
a) Determine the correct wire size	19
b) Inserting the wire into the book	19
c) Setting the closing bar height	20
d) Closing the book	21
11) Attaching Comb Opener module	I 22
Setup Instructions	
a) Determine the correct comb size	23
b) Placing the comb onto the rake	23
c) Setting the comb opener stop	23
d) Placing the book onto the comb	24
e) Margin settings	24

Setup Illustrations

Diagram 1	Punch	4
Diagram 2	Punch	5
Diagram 3	Punch	7
Diagram 4	Coil inserter	11
Diagram 5a	Coil inserter	13
Diagram 5b	Coil inserter	13
Diagram 5c	Coil inserter	14
Diagram 5d	Coil inserter	15
Diagram 5e	Coil inserter	16
Diagram 6	Wire closer	18
Diagram 7a	Wire closer	20
Diagram 7b	Wire closer	20
Diagram 7c	Wire closer	21
Diagram 7d	Wire closer	21
Diagram 6	Comb Opener	22
Diagram 9	Versa Switch	25
Troubleshooting OD 4000		8
Troubleshooting Coil Inserter Module		16
Electrical schematic OD 4000		8
Electrical schematic Coil Inserter Module		17
Die list		9&10

1) important Safety Notice!

! Make sure you read this section very carefully! Learn to recognize this Safety Alert Symbol.

The OD 4000 has been designed to provide a very high level of protection to an operator. Follow the guidelines below while installing, operating and maintaining your machine.

- + Plug the machine into an outlet that provides a 15-amp service that is protected at the customers circuit box.
- + Always replace fuses with the correct amperage and type fuse.
- + If machine cycles on its own, call dealer immediately for service.
- + Never bypass top cover switch.
- + Turn power switch off before removing a die.

2) Placing your machine in the proper location:

Place the machine on a hard level surface placing the foot pedal on the floor in front of the machine. Set aside some room for the books that have to be punched and also some room for the books that had already been punched.

3) Providing power to the machine:

Plug one end of the power cord into the back of the machine. The other end goes into the wall outlet. Install the foot pedal plug into the receptacle, which is located on the left side of the machine. The optional Versa switch can be plugged into the same receptacle if this option is to be used.

4) Die installation: Diagram 1

Make sure the machine is turned off before installing die. Install the die (1) by sliding it into the opening of the machine located on the left-hand side of the machine, Make sure the punch pin retainer (2) slides into the slot of the pusher bar. Using the two fluted knobs (3) provided with the machine, install each handle into the hole located in the front of the die and turn them clockwise to tighten. Make sure there is no paper dust in the machine die slot before installing the die.

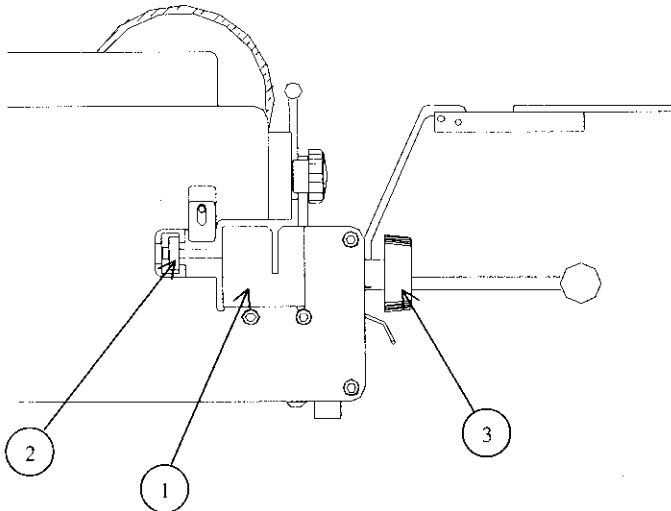

Diagram 1

+ To remove a punch pin from the die:

Make sure the machine is turned Off before removing the die. To remove a punch pin from the die, remove both fluted knobs and slide the die to the left just

enough so the punch pin can be removed. Pull the pin straight up through the die retainer. Reinstall the die using die installation procedure.

+ Die maintenance:

Die maintenance can be performed with the die installed in the machine. To perform the die maintenance, loosen the **safety screw (4)** on the top front cover and raise it up so it stays open. Using the oil provided with the machine, squeeze the plastic bottle over the oil slot that runs the entire length of the die. To much oil can run onto the paper being punched. After oiling, **always** punch scrap paper to remove excess oil.

5) Setting the paper guides: Diagram 2

The **paper guide (1)** is located on the top hinged cover. By loosening the knob (2) counterclockwise, the guide can be adjusted to the left or the right so the holes can be centered within the paper being punched. For 11" sheets, the right-hand portion of the guide can be set at the 11" mark (3) (thick vertical line).

This patented feature will allow all the 11" sheet sizes to be perfectly centered in the sheet no matter which punch pattern is being used. **When using different length sheets, the paper guide will have to be moved to a different position,**

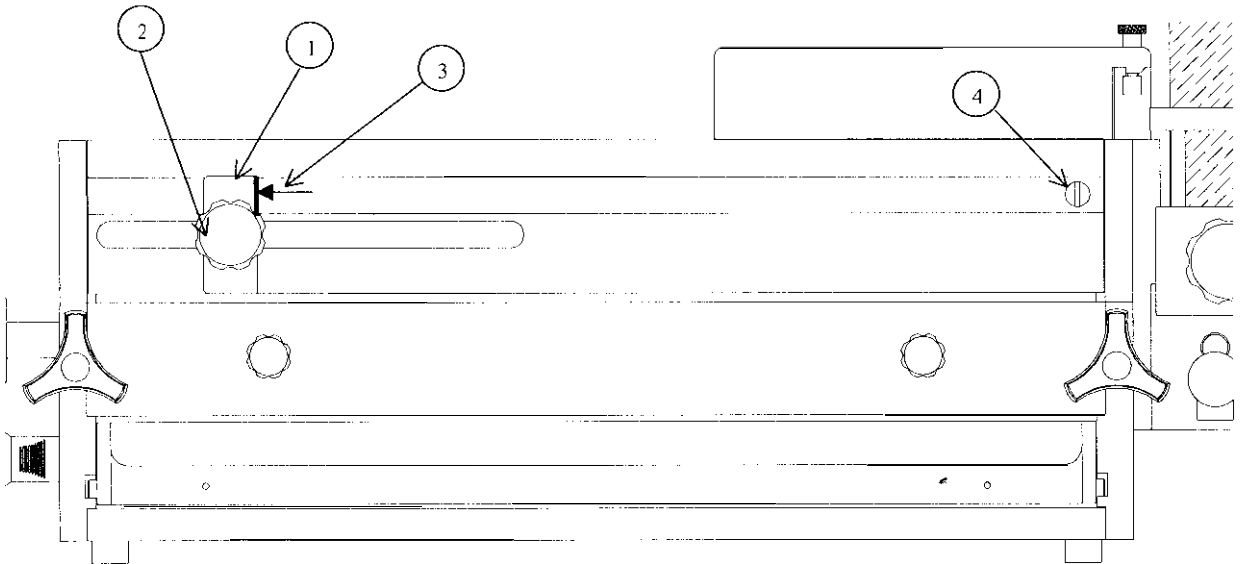

Diagram 2

Comb dies are the only kind to have an adjustable backstop. These are *special order dies and are not standard*. To change the position of the hole placement (margin) to the back edge of the sheet, first install the die into the OD 4000. Pull on the black handle, which is part of the die. There are four placement positions. Choose the position best suited for your job. Push the handle **towards the right** for the larger combs and pull it out to the left for smaller combs. The exact position will be left up to the operator's preference.

1) Punching Paper:

Position the paper that needs to be punched either to the left, right or on top of the machine. This is up to the individual operator. Remove 10 to 15 sheets (20lb bond copy paper) from the pile and slide it down vertically into the opening of the die. When the paper is fully down, slide it to the left so it comes in contact with the paper guide. Make sure all the edges of the sheets are flush by tapping the top and the right hand side of the sheets before pressing the foot pedal. After punching the sheets, place the paper on the punched pile making sure the sheets remain **in exact order**.

2) Removing paper waste: Diagram 3

The paper waste is removed by pulling towards you the **paper waste drawer (3)**. It is located directly below the die. This should be checked frequently while punching not to allow it to fill up and spill into the machine.

3) Paper Jam: (Reverse knob) Diagram 3

Unplug and turn the power off to the machine before proceeding. The reverse knob is only utilized if a paper jam occurs in the die or if the die is installed incorrectly. When a paper jam occurs, the fuse protecting the motor may have to be replaced. This is normal and allows maximum protection for the punch motor.

- + Push in and turn the reverse knob (1) counter clockwise about 8-10 times so the punch pins (2) start to move out of the paper in which it had jammed. This should be enough to allow the paper to become free of the die. (This knob is normally tight and requires a firm grip to turn it the small amount necessary to *remove the* paper from the die.)
- + Plug the machine back into the wall outlet and turn the main power switch on
- + Press the foot pedal to see if the machine operates. If yes, reinstall the die and continue punching the job. If the machine does not function, see replacing the fuses in the troubleshooting section of this manual.

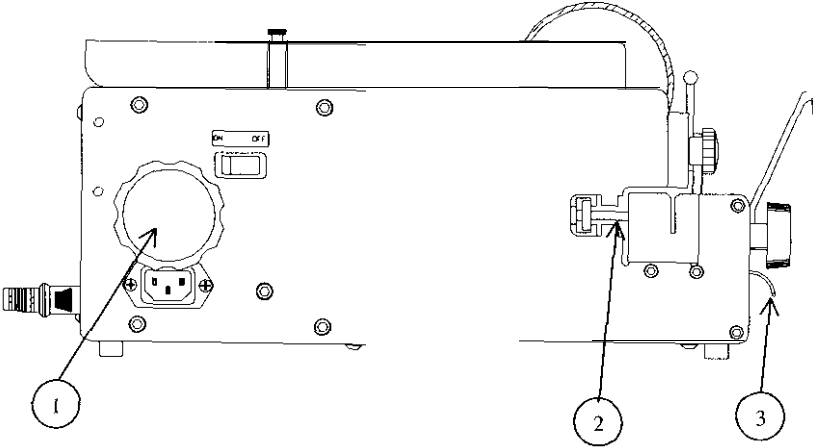

Diagram 3



Only qualified personal should attempt to work on this equipment.

There is not much to go wrong with the OD 4000 punch. Most of the problems are due to setup error. There are two fuses located at the rear of the punch that can be replaced by the customer. Here is a small troubleshooting guide to help you through some of the problems that may be encountered.

Troubleshooting

Symptom	Possible Cause	Action
Machine does not cycle.	<ol style="list-style-type: none"> 1) Machine is off. 2) Machine not plugged in. 3) Foot pedal not plugged into machine. 4) Top Cover Switch. 5) Blown fuse. 	<ol style="list-style-type: none"> 1) Check power switch. 2) Check both ends of power cord. 3) Make sure foot pedal cable is attached to machine. 4) Close top cover. 5) Check Fuse 1 (5A). Check Fuse 2 (2A). Slow blow
Die does not go into machine.	<ol style="list-style-type: none"> 1) Pin retainer interference. 2) Punch stopped in mid cycle. 3) Pins not flush with pin retainer. 	<ol style="list-style-type: none"> 1) Make sure pin retainer enters slot in pusher bar. (see diagram 1) 2) Check fuses and restart machine. 3) Make sure that all the pins are flush against pin retainer.

OD 4000 Electrical Schematic (120 volt AC)

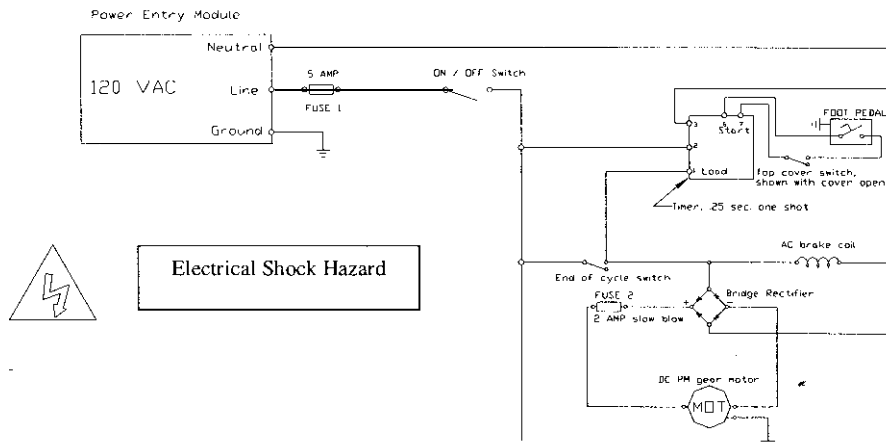

This product has earned the UL Listing Mark and the UL Listing Mark for Canada. E179574. The OD 4000 has been tested with a duty cycle of 20 cycles per minute with a 2 minute rest period after 30 seconds of run time.

Die list:

This is a list of the most common dies manufactured by Performance Design. Special dies are available. Ask your dealer for more information.

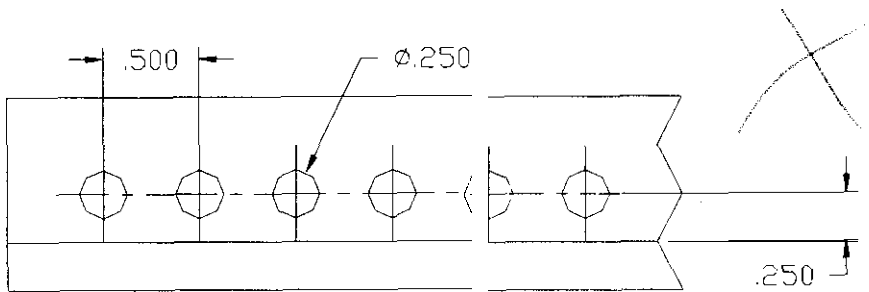

2 To 1 Round

Drawings are to scale.

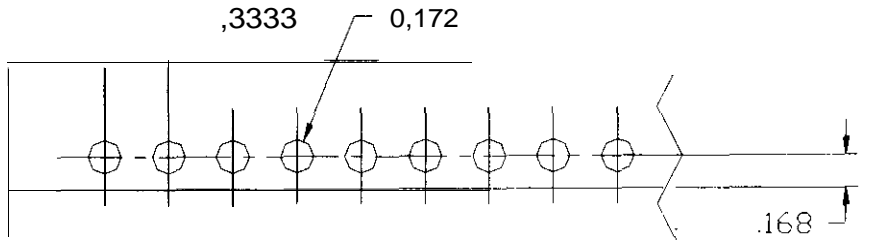

3 To 1 Round

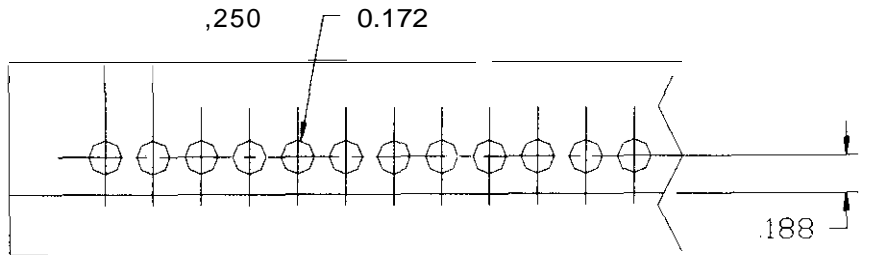

4 To 1 Round

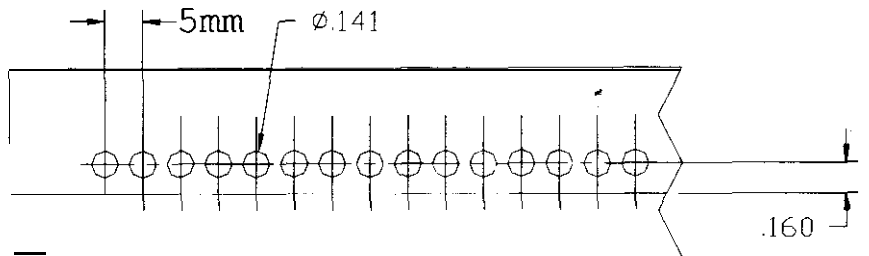

5 To 1 Round (5mm)

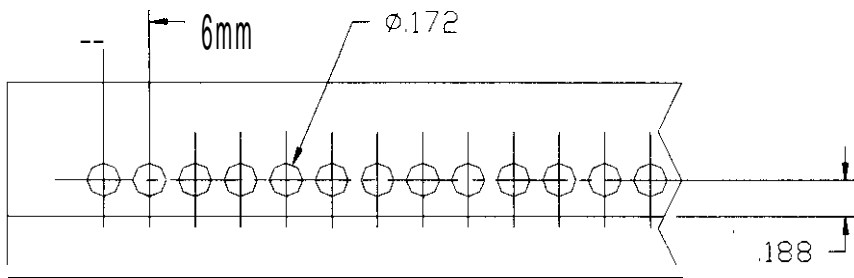

6MM Round

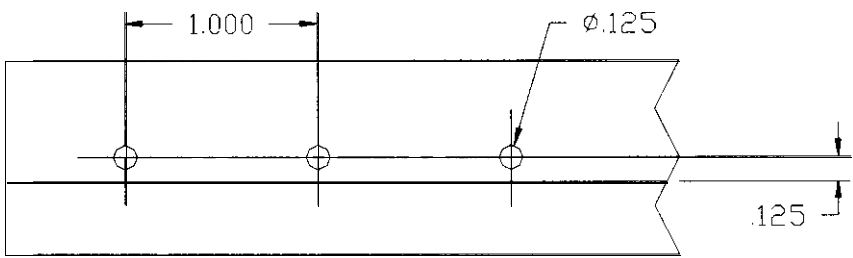

Velobind[®] Velobind is a registered trademark of GPC

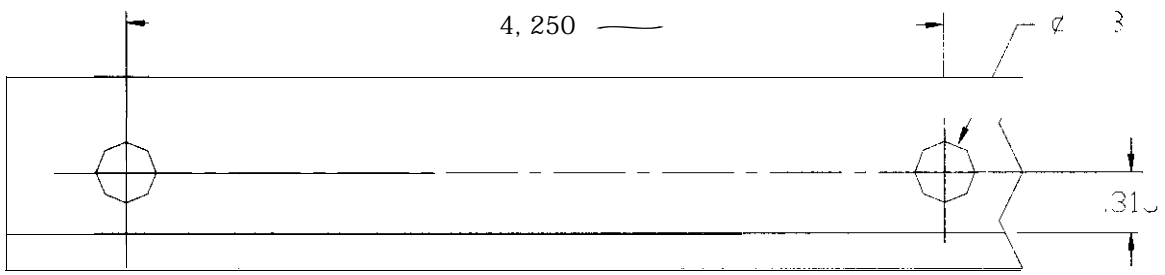

3 Hole X 5/16

Drawings are to scale.

X

Drawings are to scale.

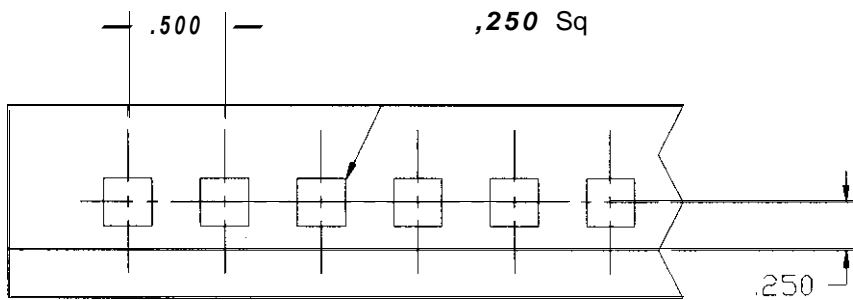

2 To 1 Square

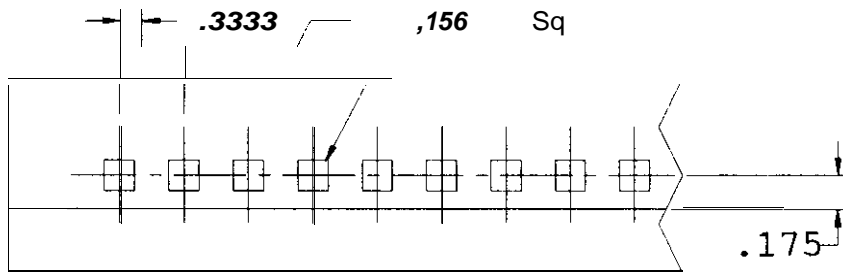

3 To 1 Square

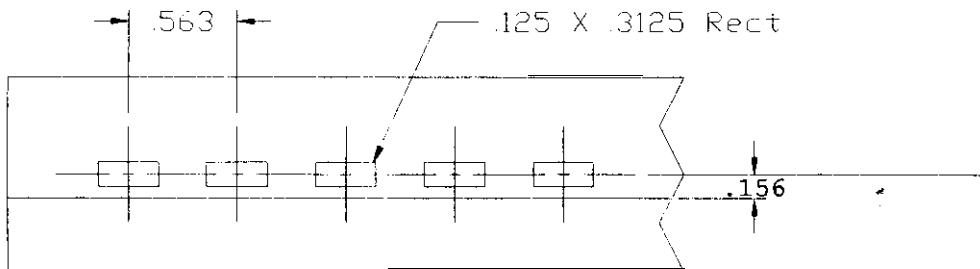

Comb

*Fixed Back Spacing Die

Coil Inserter Module

1) Installation Instructions: Diagram 4

Procedure to attach the coil inserter onto the OD 4000 punch

- ◆ **Unplug the main power cord from the OD 4000.**
- ◆ Loosen the safety screw and open the top cover on the OD 4000.
- ◆ Align the two **threaded studs (1)** that protrude from the coil inserter option into the two holes located on the right side of the OD 4000.
- ◆ Use the two wing nuts provided with the coil inserter to attach the unit. Hand tighten the two wing nuts.
- ◆ Attach the paper **stop bracket (2)** to the right side of the OD 4000 using the **two black thumb knobs (3) provided.**
- ◆ **Attach the paper stop (4)** to the paper stop bracket by sliding the square nut into the slot of the paper stop bracket. This can be positioned and tightened by the knob (5) at a latter time when setting the guides to the paper.
- ◆ Use two black thumb knobs (6) to attach the book table / lexan coil guide to the OD 4000. (The book table / lexan guide has been removed to view the diagram, see diagram 5b to view the book table / lexan guide in position)
- ◆ **Plug** one end of the power cord into the back of the coil option and the other end into the wall outlet. **Both the OD 4000 and the coil option have power cords.**

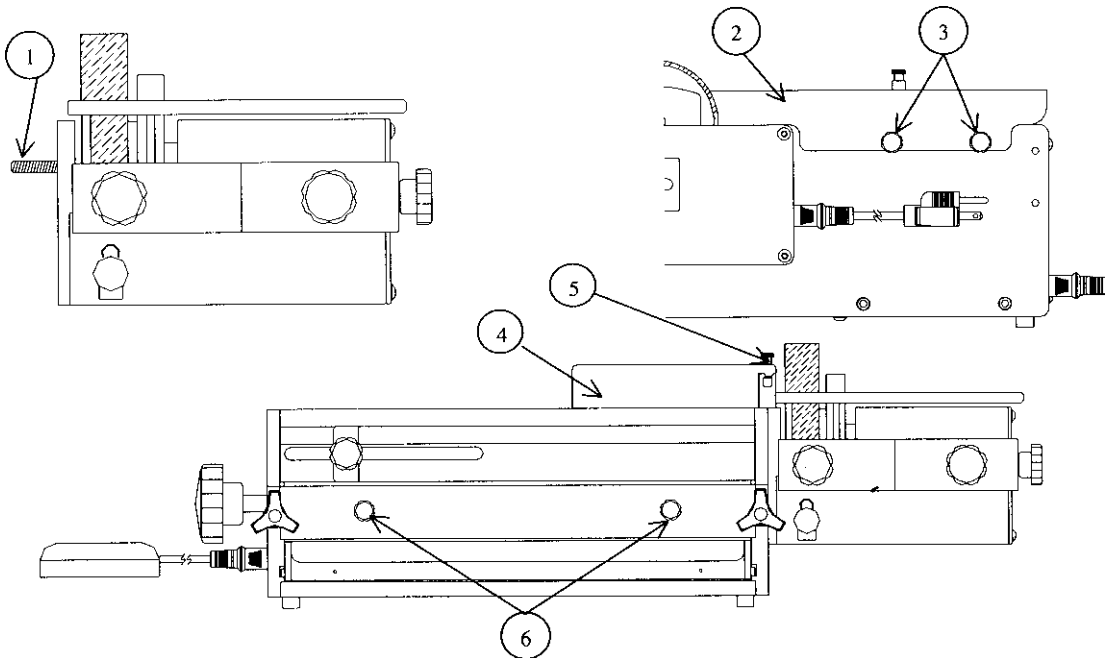

Diagram 4

Setup Instructions: Diagram 5a, 5b, 5c, 5d & 5e

a) Determine the correct size coil.

Use a coil that is at least $\frac{3}{32}$ " (2.5mm) larger than the book thickness for coil sizes up to $\frac{3}{4}$ " (20mm). After $\frac{3}{4}$ ", use a coil size of at least $\frac{1}{8}$ " over the book size. The larger the coil compared to the book, inserting will become much easier.

b) Determine the correct size mandrel

There are a total of nine mandrels, which are used for coil sizes $\frac{3}{16}$ " (5mm) up to $1\text{-}\frac{1}{4}$ " (30mm). Use the below table to choose the correct mandrel size to coil size.

<u>Mandrel size</u>	<u>Inch</u>	<u>Coil size mm</u>
$\frac{3}{16}$ "	$\frac{3}{16}$ " to $\frac{1}{4}$ "	(5mm-6mm)
$\frac{1}{4}$ "	$\frac{5}{16}$ "	(7mm-8mm)
$\frac{5}{16}$ "	$\frac{3}{8}$ "	(9mm-10mm)
$\frac{3}{8}$ "	$\frac{7}{16}$ " to $\frac{1}{2}$ "	(11mm-12mm)
$\frac{1}{2}$ "	$\frac{9}{16}$ "	(13mm-16mm)
$\frac{5}{8}$ "	$\frac{3}{4}$ "	(17mm-19mm)
$\frac{3}{4}$ "	$\frac{7}{8}$ "	(20mm-23mm)
$\frac{7}{8}$ "	1"	(24mm-27mm)
1"	$1\text{-}\frac{1}{8}$ " to $1\text{-}\frac{1}{4}$ "	(28mm-30mm)

c) Installing the mandrel on the machine.

- + Place the mandrel (1) into the mandrel holder bracket (2) making sure the beveled edge of the mandrel is facing the right side of the machine. Both guide pins located on the mandrel need to line up with both slots on the mandrel bracket. Use the black knob (3) to tighten the mandrel in place.
- + Adjust the height of the mandrel so the center of the mandrel is the same height as the center of the book.

d) Adjusting the mandrel bracket

- + The mandrel assembly-adjustment knob (4) is located on the right side of the coil inserter. Move the mandrel bracket assembly towards the drive wheel for small mandrels and away from the drive wheel for the larger mandrels.
- + The mandrel holder bracket-adjustment knob (5) can be adjusted to the left or the right so the leading edge of the coil lines up with the first hole of the book.

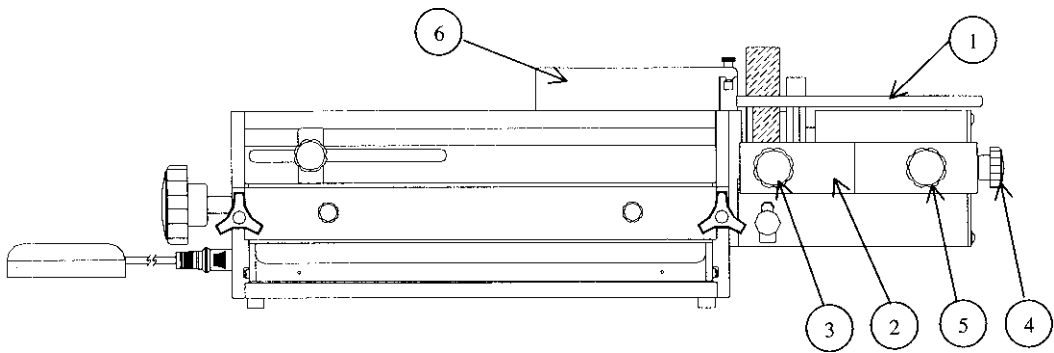

Diagram 5a

e) Adjusting the paper stop.

Place the book on the top cover of the punch with the right side of the book against the paper stop bracket. Adjust the paper stop **(6)** so the holes of the book hang over the edge of the front cover on the OD 4000 punch. The holes should **hang over the edge just enough for the coil to clear the cover**. Tighten the knob located on the paper stop bracket. It may be necessary to fine-tune this after a few books are bound for exact placement.

f) Adjusting the front table / lexan guide

The front table/lexan guide **(7,7a, & 7b)** has two purposes. (FIRST): When the lexan is in the closed position, **rotated on top of the coil (7a)**, it will assist the coil to insert smoothly into the book. You should use the lexan guide with all books regardless of thickness. (SECOND): With the lexan guide (plastic) in the open position, **rotated away from the machine**, it acts as a **support table 7b)** for large books. For books over 9/16" thick, it may be necessary at times to start the coil into the book, then split the book in half using the table to support one half of the book, then finish the inserting of the coil. This method improves productivity.

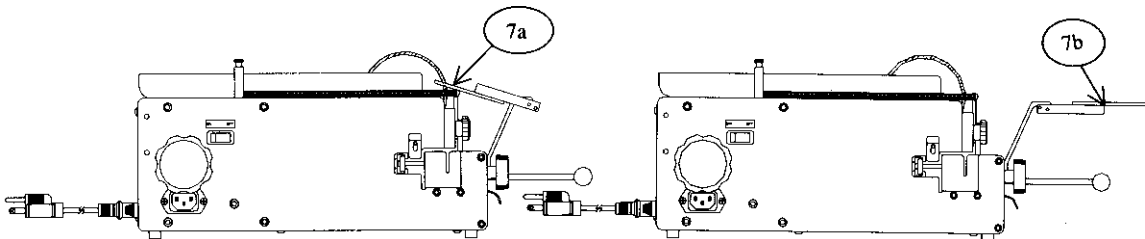

Diagram 5b

cd Forward /off / reverse switch

The forward | off | reverse (8) switch has three positions. The center position of this switch is the off position and should be placed in this position when not using the machine. Press the left side (forward) of the switch and the coil will rotate into the book. Press the right side (reverse) of the switch and the coil will exit the book. The reverse feature allows the coil to be removed from the book. Sometimes this will be necessary when the leading edge of the coil misses a hole of a single sheet.

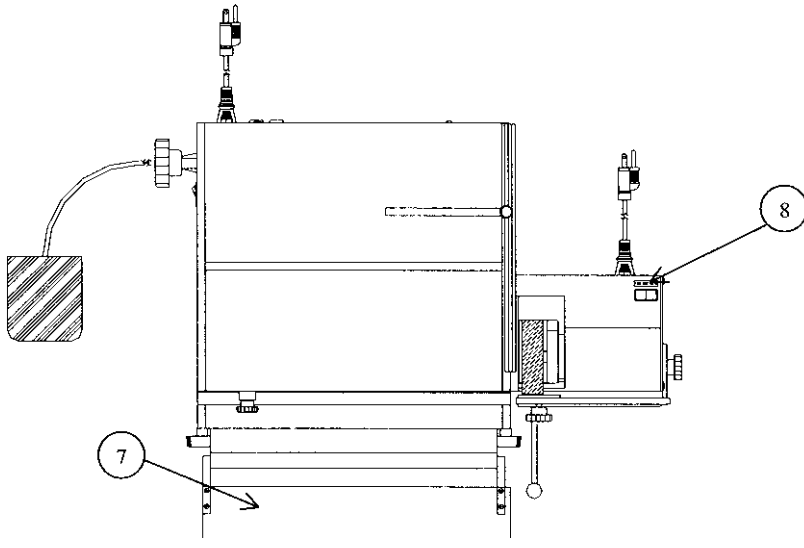

Diagram 5c

h) Inserting a coil.

Place the coil on the mandrel by sliding the open end of the coil onto the beveled end of the mandrel. Turn the coil so it threads onto the mandrel post (9) and is in front of the drive wheel by one coil. Make sure the forward / reverse switch is in the forward position. Pull the handle (10) down to start the motor and engage the drive wheel (11) to the coil. Rotate the coil so it comes close to the edge of the book, but not past the book. With your right hand, hold the leading edge of the coil and thread it through the first two holes of the book. This helps align the holes of the book. Rotate the lexan guide on top of the coil. Pull the handle down gently at first making sure the coil is rotating into the book without missing holes in the sheets or covers. Continue until the coil is past the left side of the book by about one or two coils.

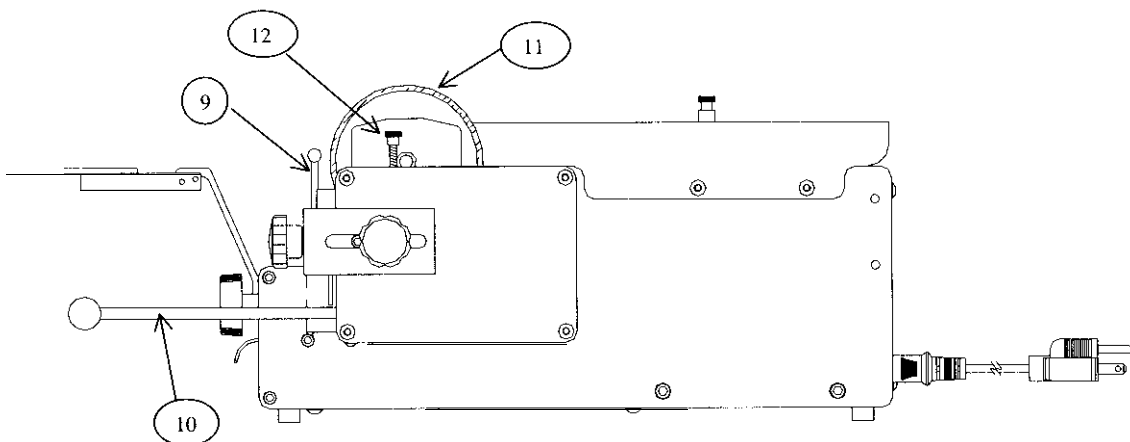

Diagram 5d

i) Drive wheel stop screw,

The **drive wheel** stop screw (12) will prevent the wheel from pressing too hard on the mandrel. It is very important not to have too much pressure on the mandrel when inserting the larger coils. If the leading edge of the coil stops on a misaligned sheet, the coil wants to tie itself into a knot between the book and the end of the mandrel. Setting the stop screw will prevent this from happening most of the time. To set the stop screw, turn it clockwise to push the wheel away from the mandrel. Load the coil onto the mandrel and turn the stop screw counter clockwise while holding down on the motor handle (10) until the drive wheel touches the coil. Try a few books and readjust if necessary.

If the mandrel bracket is adjusted **after the stop screw has been adjusted, it will be necessary to readjust the stop screw**

j) Cutting the coil

There are special cutter crimper pliers (ordered separately) that are used to terminate the ends of the coil. After the coil is cut, the sharp end of the coil will tuck itself under the inside of the coil opening. To use the cutter, make sure the red dot (13) is facing up. Place the cutter on the edge of the right hand side of the book. Open the cutter enough so that the end of the cutter enters the coil by about 1/4". **Make sure the cutter is level with the book before you cut. As you squeeze** the cutters you may notice the coil wants to twist. You can support the coil with your fingers as you cut to help stabilize the coil. Turn the book over and repeat these steps on the opposite end of the book. Always make sure to close crimping cutters completely.

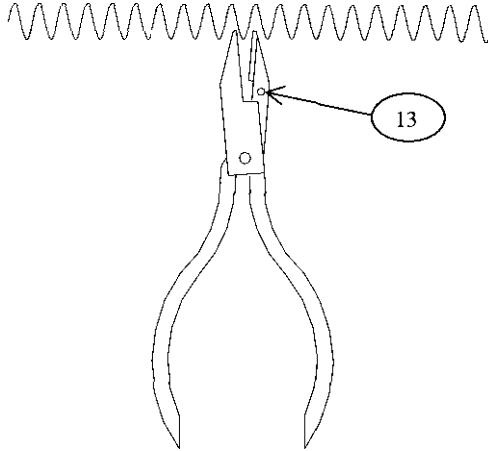

Diagram 5e



Only qualified **personal should attempt to work on this equipment.**

There is very little that can go wrong with the Coil Inserter Module. Most of the problems are due to setup error. There is one fuse located at the rear of the inserter that can be replaced by the customer. Here is a small troubleshooting guide to help you through some of the problems that may be encountered.

Troubleshooting

Symptom	Possible Cause	Action
Drive wheel does not rotate. (There is a thermal overload built inside of the motor. Wait several minutes below checking the fuse)	<ol style="list-style-type: none"> 1) Machine is off. (switch is in center position) 2) Machine not plugged in, 3) Blown Fuse. 	<ol style="list-style-type: none"> 1) Place switch in either Forward or Reverse position. 2) Check both ends of power cord. 3) Check Fuse 1. (5amp)
Coil tightens on the mandrel when inserting.	<ol style="list-style-type: none"> 1) Mandrel is too small for coil. 	<ol style="list-style-type: none"> 1) Select proper size mandrel. (see page 12)
Coil stops before it is completely through the book.	<ol style="list-style-type: none"> 1) The holes in the book are misaligned. 2) The coil is beyond drive wheel. 	<ol style="list-style-type: none"> 1) This is normal. Try moving the book around so the coil rotates in the holes. 2) Coil length may need to be longer for that particular book. Note: On larger coils, they can wind themselves open so that

Coil Inserter Module Electrical Schematic (120 volt AC)

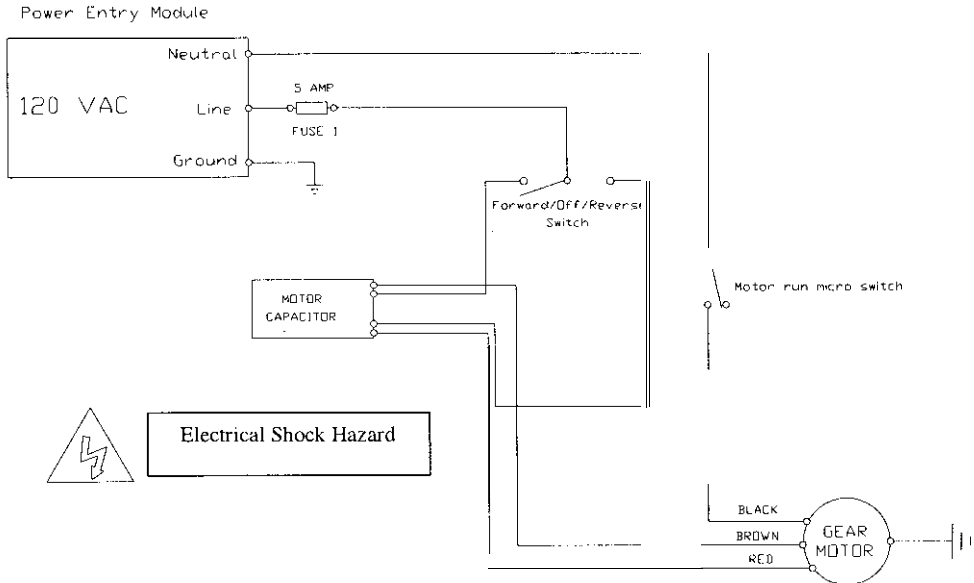

NOTE: The motor is protected by a thermal overload located in the motor. It will reset automatically after the motor cools.

This product has earned the UL Listing Mark and the UL Listing Mark for Canada. EI 79574

The CI 3000 has been tested with a duty cycle of 4 seconds on, 15 seconds off with a rest period of 2 minutes after 30 seconds of run time.

The CI 3000 is also known as the Coil Inserter Module 4300.

Wire Closer Module

10) installation Instructions: Diagram 6

Procedure to attach the wire closer onto the OD 4000 punch

- ◆ **Unplug the main power cord from the OD 4000 punch.**
- ◆ Place the closer module on the backside of the OD 4000 punch so the closer adjustment knobs are facing the front of the punch and are pointing up.
- ◆ Attach the closer with four black knobs (1) provided with the closer module. Use two knobs on each side to secure the unit in position.
- ◆ Attach the closing handle (2) to the right side of the closer using the special washer & screw (3) provided with the closing module. Use the allen key provided with the closing module to secure the handle in place.
- ◆ **Optional wire holder**
The wire holder (4) will hold a wire so the book can be placed onto the narrow loops of the wire. It is mounted to the chip drawer located on the front side of the OD 4000. The chip drawer should be removed for this procedure. There are **two round spacers (5)** that go behind the wire holder. Mount the wire holder with the open end facing away from the top of the chip drawer. Now insert the screw into the hole of the wire holder, through the spacer and turn it into the chip drawer mounting hole. Use a small screwdriver to mount the holder to the chip drawer.
- ◆ The book table / lexan guide & the top paper stop assembly should be removed while using the wire closing module.

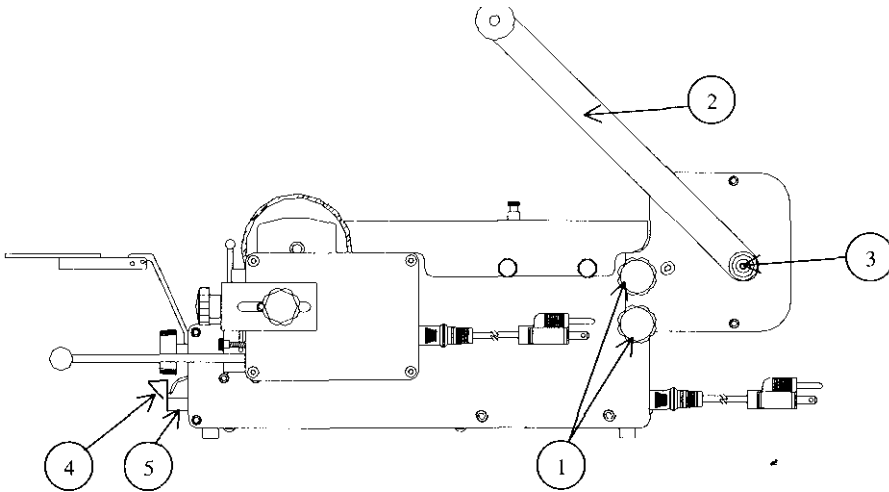

Diagram 6

Setup Instructions: Diagram 7a, 7b, 7c & 7d

a) Determine the correct wire size.

Use the table below to determine the correct wire size for the book thickness. You can insert more sheets into the wire, but it may affect the appearance of your book. Covers are not included with the number of sheets column.

Wire Diameter		Book Thickness		Number of sheets	
Inch	mm	Inch	mm	20lb	80asm
3/16	4.8	1/8	3.2	30	
1/4	6.4	3/16	4.8	45	
5/16	7.9	1/4	6.4	65	
3/8	9.5	5/16	7.9	80	
7/16	11.1	3/8	9.5	95	
1/2	12.7	7/16	11.1	110	
9/16	14.3	1/2	12.7	125	
5/8	15.9	9/16	14.3	140	
3/4	19	5/8	15.9	160	
7/8	22.2	3/4	19	190	
1	25.4	7/8	22.2	220	
1-1/4	31.8	1-1/8	28.6	285	

b) Inserting the wire into the book

There are two methods for inserting the wire into the book. First, prep the book by removing the back cover and place it on top of the front cover. This will position the binding edge of the wire at the inside cover at the back of the book.

- + The traditional way to insert the wire is to place the book on the edge of a table so the holes overhang the table a slight amount. Make sure the covers are facing down when placing the book on the table. Insert the narrow loop into the holes of the book with a slight rotating action. Start with the left side and slide your finger along the wire to thread it into the remaining holes.
- + The wire holder option is also used for inserting a wire. Place the wide loop (1) of the wire under the lip of the wire holder. Take the book with the covers in the correct position (covers on top)(2) and place the book onto the narrow loops of the wire.

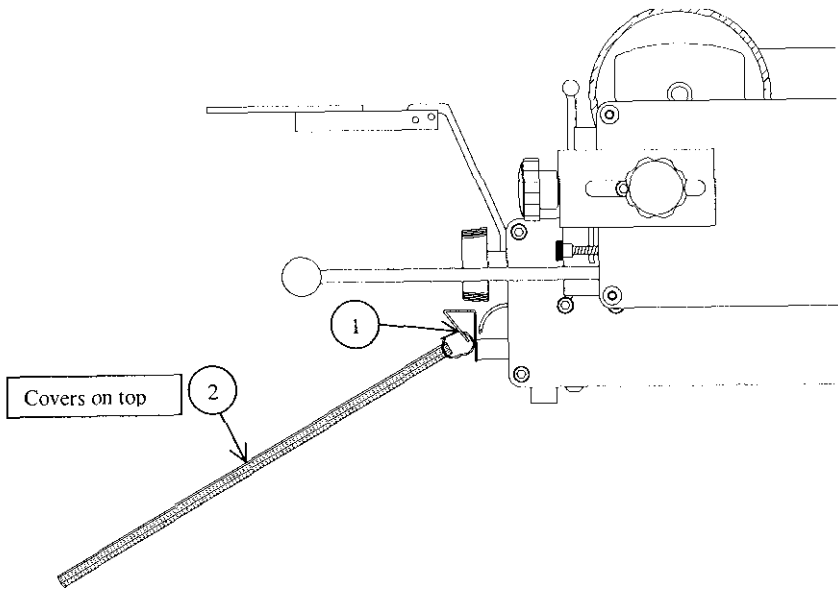

Diagram 7a

c) Setting the closing bar height.

The closing bar is adjustable on each end allowing the operator to achieve a perfect close at each end of the book. Pull the handle on the closer all the way down and adjust both knobs (3) so the **top edge** (4) of the closing bar lines up with the **line** (5) next to the wire size you want to close.

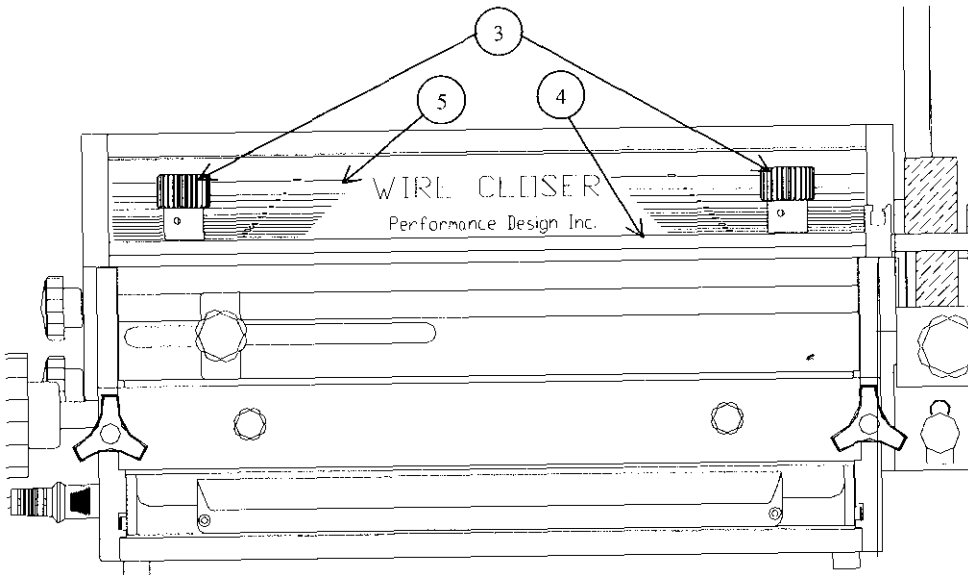

Diagram 7b

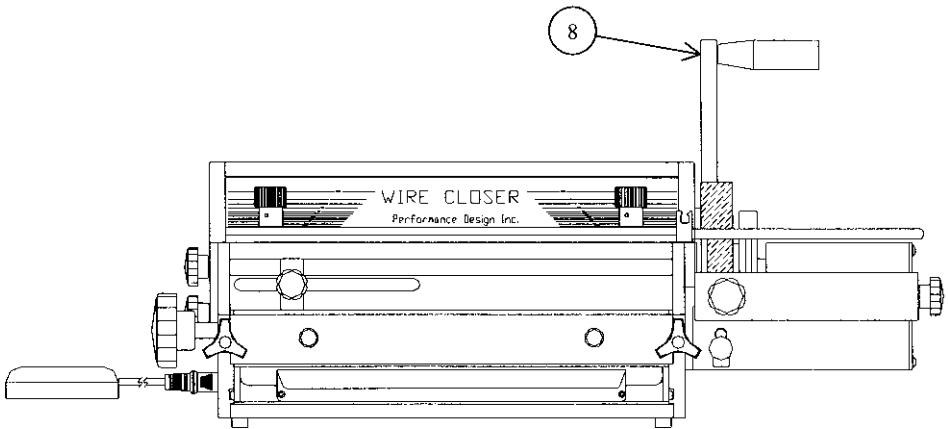

Diagram 7c

d) Closing the book

Place the book so the open end of the wire is firmly pressed against the back **plate (6)** inside the closing machine. The narrow **loop (7)** should be on the top of the book while pushing the book against the back plate. Hold the book with your left hand as you pull the **handle (8)** down with your right hand. Inspect the close and readjust the wire if necessary. When the wire is closed properly, the narrow loop overlaps the wide loop by about **1/16"** along the entire length of the book. An indication that the wire is not closed tight enough is when the covers or sheets fall out of the book.

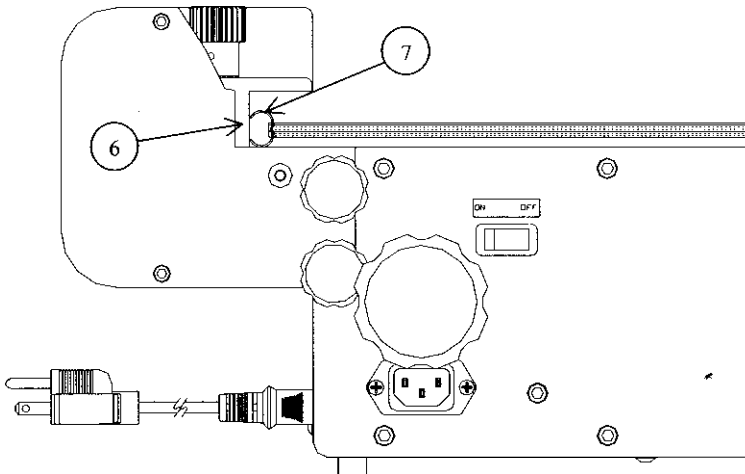

Diagram 7d

Comb Opener Module

11) Installation Instructions: Diagram 8

Procedure for attaching the comb opener onto the OD 4000 punch.

- + **Unplug the main power cord from the OD 4000 punch.**
- + Place the comb opener module on the backside of the OD 4000 punch so the narrow section of the comb opener is facing the front of the OD 4000 punch.
- + Attach the comb opener with **four black knobs (1) provided with the comb opener** module. Use two knobs on each side to secure the unit in position.
- + Attach the comb opener handle (2) to the left side of the comb opener using the washer & screw provided with the comb opener module. Use the allen key provided with the comb opener module to secure the handle in place.

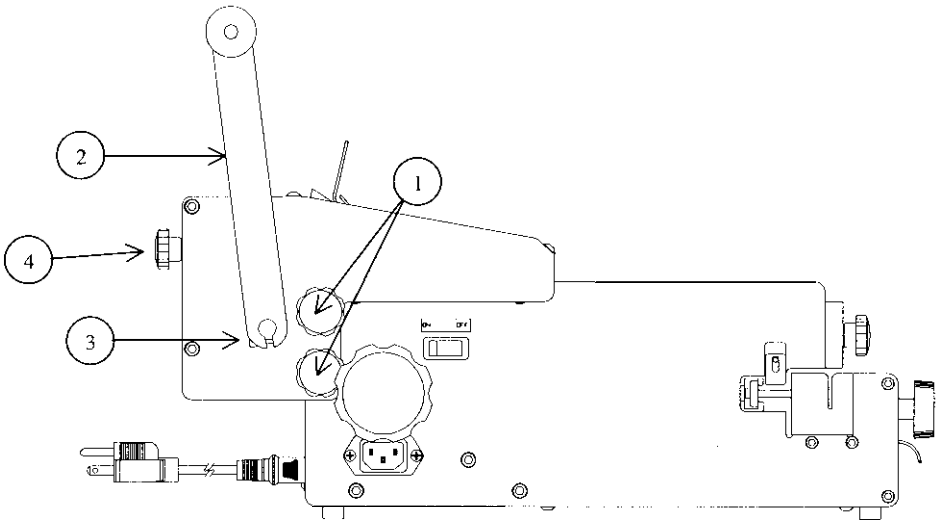

Diagram 8

a) Determine the correct comb size.

Use the table below to determine the correct comb size for the book thickness. You can insert more sheets into the comb, but it may affect the appearance of your book. Covers are not included with the number of sheets column.

Comb Diameter		Book Thickness		Number of sheets	
Inch	mm	Inch	mm	20lb	80gsm
3/16	4.8	1/8	3.2	30	
1/4	6.4	3/16	4.8	45	
5/16	7.9	1/4	6.4	65	
3/8	9.5	5/16	7.9	80	
7/16	11.1	3/8	9.5	95	
1/2	12.7	7/16	11.1	110	
9/16	14.3	1/2	12.7	125	
5/8	15.9	9/16	14.3	140	
3/4	19	5/8	15.9	160	
7/8	22.2	3/4	19	190	
1	25.4	7/8	22.2	220	
1-1/8	28.6	1	25.4	250	
1-1/4	31.8	1-3/32	27.8	275	
1-1/2	38.1	1-3/16	30.1	300	
1-3/4	44.5	1-7/16	36.5	360	
2	50.8	1-11/16	42.8	425	

b) Placing the comb onto the rake.

Place the comb onto the rake with the fingers of the comb facing the front of the machine. The solid section of the comb will be facing the rear of the machine. Make sure the points of the fingers are facing up.

c) Setting the comb opener stop

The comb opener stop knob (4) is located on the rear of the comb opener. Set the comb opener stop by turning the knob counter clockwise so the comb opens far enough to place a book on the fingers of the comb, but not to far so the comb is lying flat with no room for the book.

d) Placing the book onto the comb.

Place the holes of the book on the fingers of the comb. A slight rotating of the book will help guide the holes onto the comb. Return the opener handle to close the comb into the book. The binding process is now complete.

e) Margin setting

The margin on a standard comb die is fixed at $3/32$ ". This margin will work fine until you bind books up to about 1" in comb size. After that, there is too little paper between the edge of the hole and the edge of the sheet. Tearing of a sheet out of the book can occur when handling the book too rough. It is recommended when binding books beyond this size you use the **optional variable backstop comb die.**

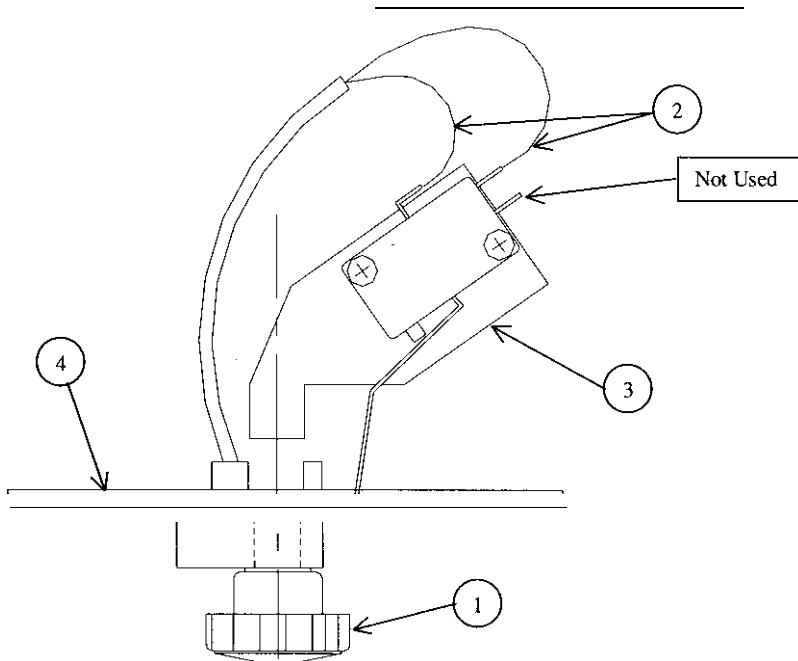

Diagram 9

12) Attaching the Versa Switch to OD 4000: Diagram 9

The versa switch replaces the foot pedal and paper stop. By pushing the paper against this switch, it positions the paper in the correct location so the holes are centered in the sheet and also activates the punch.

- ◆ Unplug the main power cord from the OD 4000 punch.
- ◆ Remove the foot pedal plug from the left side of the OD 4000 punch.
- ◆ Install the versa switch plug into the same receptacle that the foot pedal plug was removed from.
- ◆ Remove the paper stop from the front cover of the OD 4000.
- ◆ The Versa switch comes fully assembled. The **knob (1)** will have to be removed from the assembly. Also, the **two wires (2)** attached to the switch will have to be removed.
- ◆ Place the switch **bracket (3)** inside the cover (4) and the paper stop through the slot of the cover. Use the knob to attach the assembly back to the original configuration.
- ◆ Reattach both wires to the same terminals of the switch.

STANDARD PUNCH PATTERNS Shown an 100%



3-hole X 5/16" - OD 4000, #41300



2 per inch X 1/4" - OD 4000, #41210



6mm - OD 4000, #40660



3 per inch X 11/64" - OD 4000, #41310



4 per inch X 11/64" - OD 4000, #41410



5 per inch X 1/8" - OD 4000, #41510



Velo Bind - OD 4000, #41000



Comb Bind - OD 4000, #42000



2 per inch X 1/4" square - OD 4000, #42210



3 per inch X 5/32" square - OD 4000, #42310

Special order dies for special hole patterns are available. Please call for specifications and pricing.