

OPERATING INSTRUCTIONS

EZ27 **Roll** **Laminator**

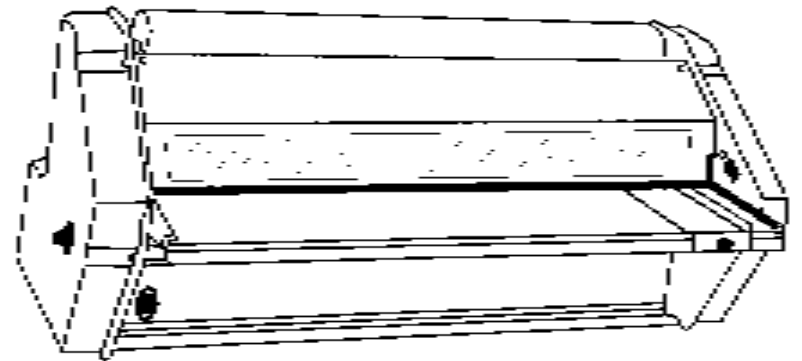
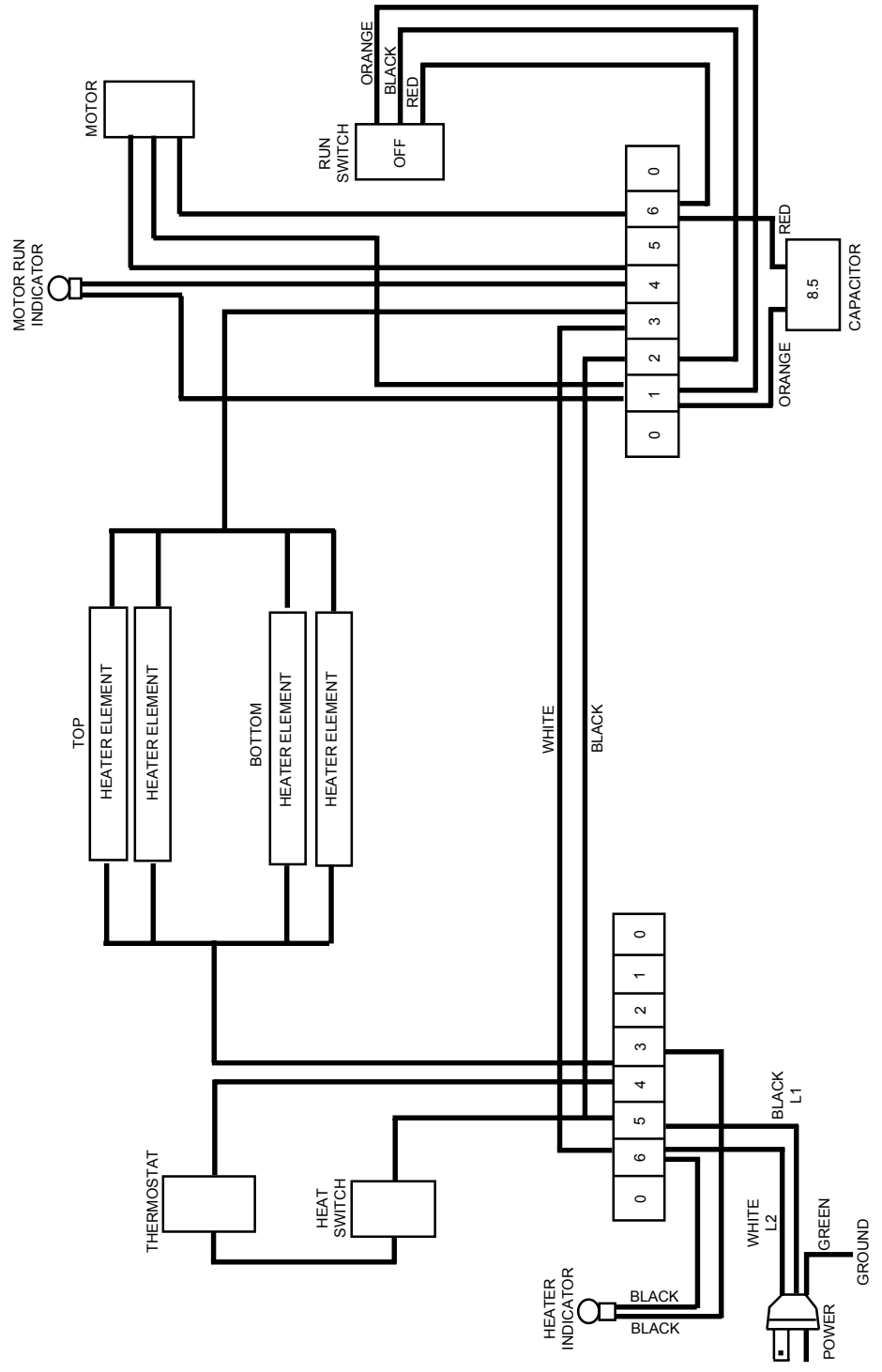
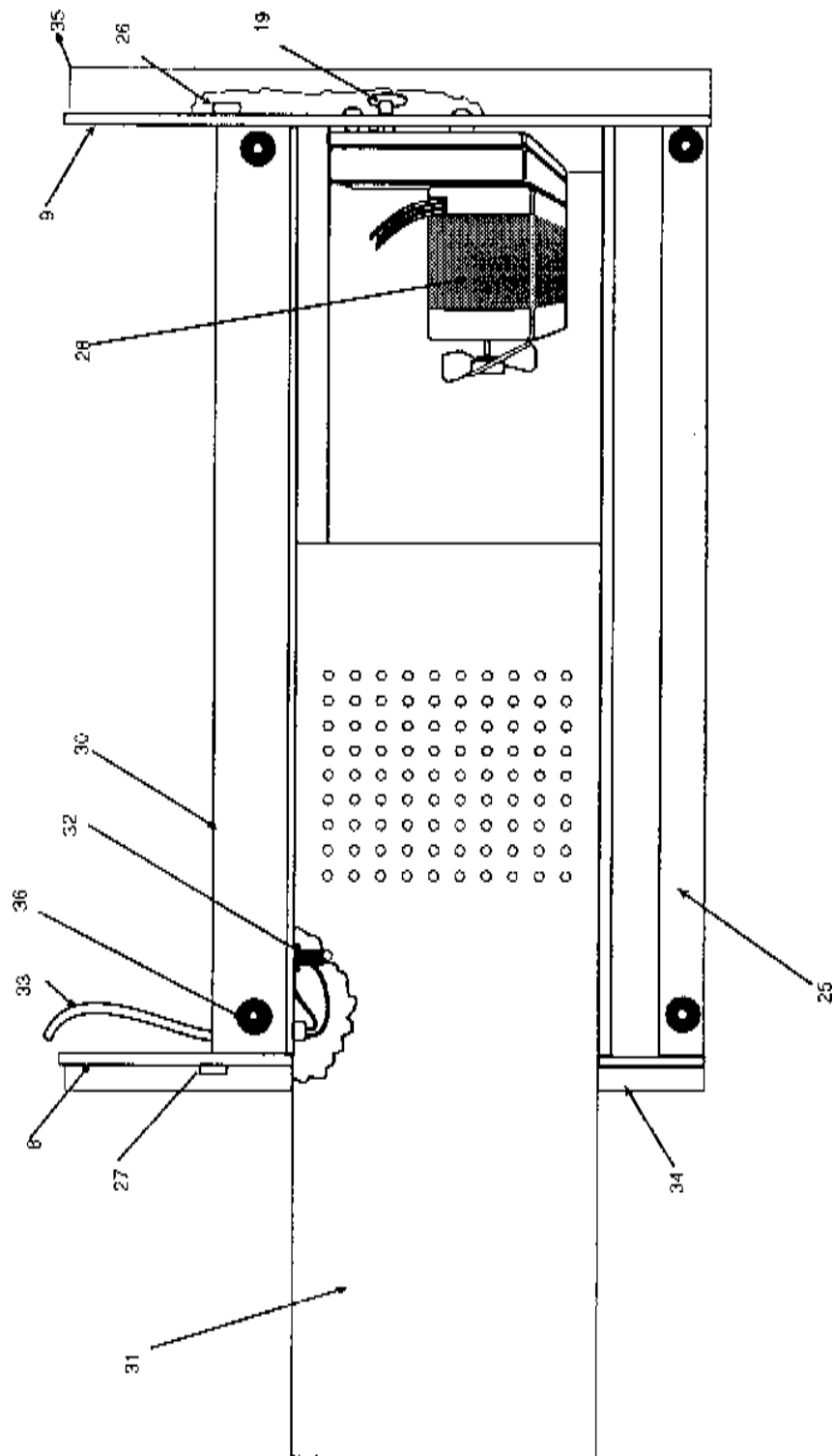

TABLE OF CONTENTS

Safety Messages and Electrical Safeguards	1-2
Introduction	2-3
Laminator Features	3
Specifications	3
Initial Set-up	4-5
Unpacking	4
Feed Table Assembly	4
Components	4,5
Operation	5-8
Loading Laminating Film	5,6
Threading Laminating Film	6,7
Roller Tension	7
Heat Shoe Temperature	8
Laminating	8-9
Troubleshooting	9-10
Maintenance	10-11
Cleaning Heat Shoes & Rollers	10,11
Warranty & Return Policy	11
Parts List	12-13
Parts Illustrations	14-17
Exploded View	14
Side Panels	15
Motor Assembly	16
Wiring Diagram	17





IMPORTANT SAFETY MESSAGES AND ELECTRICAL SAFEGUARDS

For your protection, do not connect the laminator to electrical power or attempt to operate it until you read these instructions completely. Keep these instructions in a convenient location for future reference. This instruction manual and labels affixed to the laminator are important safety messages. Read these messages carefully.

For your safety...

- * Keep hands, long hair, clothing, and other loose articles such as jewelry and ties, away from laminator's moving parts.
- * Save these Operating Instructions for later use.
- * Do not touch the heat shoes while the laminator power is turned on. Allow shoes to cool completely before touching.
- * Do not use the laminator for other than its intended purpose.
- * Place laminator on a sturdy cart, stand, or table. A laminator placed on an unstable surface may fall, causing serious bodily injury. Move laminator with caution. Quick stops, excessive force, or uneven floor surfaces may cause the laminator and cart to overturn.
- * Never override or attempt to defeat electrical or mechanical safety interlock devices.
- * Never insert objects or spill liquids in or on the laminator. They may contact dangerous voltage points or short out components that could result in fire or electrical shock.
- * The laminator should only be operated from the type of power source indicated in these Operating Instructions and on the data plate located on the rear panel of the laminator.
- * The three-pronged grounding plug is a safety feature and will only fit into a grounding-type power outlet. If you are unable to insert the plug into an outlet contact a qualified electrician to have a suitable outlet installed.
- * Do not leave the laminator power on overnight. Unplug the laminator at the end of the day.

- * Unplug the laminator before moving it or when it is not in use for an extended period of time as a precaution against the possibility of an internal malfunction that could create a fire hazard.
- * Do not operate the laminator with a damaged power supply cord or plug, or after it malfunctions or has been damaged in any manner.
- * Keep the power cord away from hot or wet surfaces.
- * Do not overload electrical outlets beyond their capacity as this can result in fire or electrical shock. This unit is rated at 15 amps (12 amps CSA) and should be the only item plugged into a 15 or 12 amp branch circuit. When connected to a 20 amp branch circuit any items in addition to the EZ27 must not exceed 4 amps.
- * Adjust only those controls that are specified in these Operating Instructions.
- * Do not attempt to service or repair the laminator yourself. Unplug the laminator from the electrical outlet and contact an authorized service representative under any of the following conditions:
 - When the power supply cord or plug is damaged or frayed.
 - If liquid has been spilled into the laminator or it has been exposed to water.
 - If the laminator has been subjected to excessive jarring through being dropped or bumped.
 - If the laminator does not operate normally when following the operating instructions.

INTRODUCTION

Congratulations on your purchase of the EZ27 Roll Laminator. This unit is designed to provide years of trouble-free service.

The EZ27 will accept rolls of laminating film up to 27" wide in both 1.5 and 3 mil thicknesses. Paper and card stock up to 80mm thick may be laminated without adjusting the feed rollers. Individual temperature controls and indicators provide uniform temperature on both sides of the item being laminated.

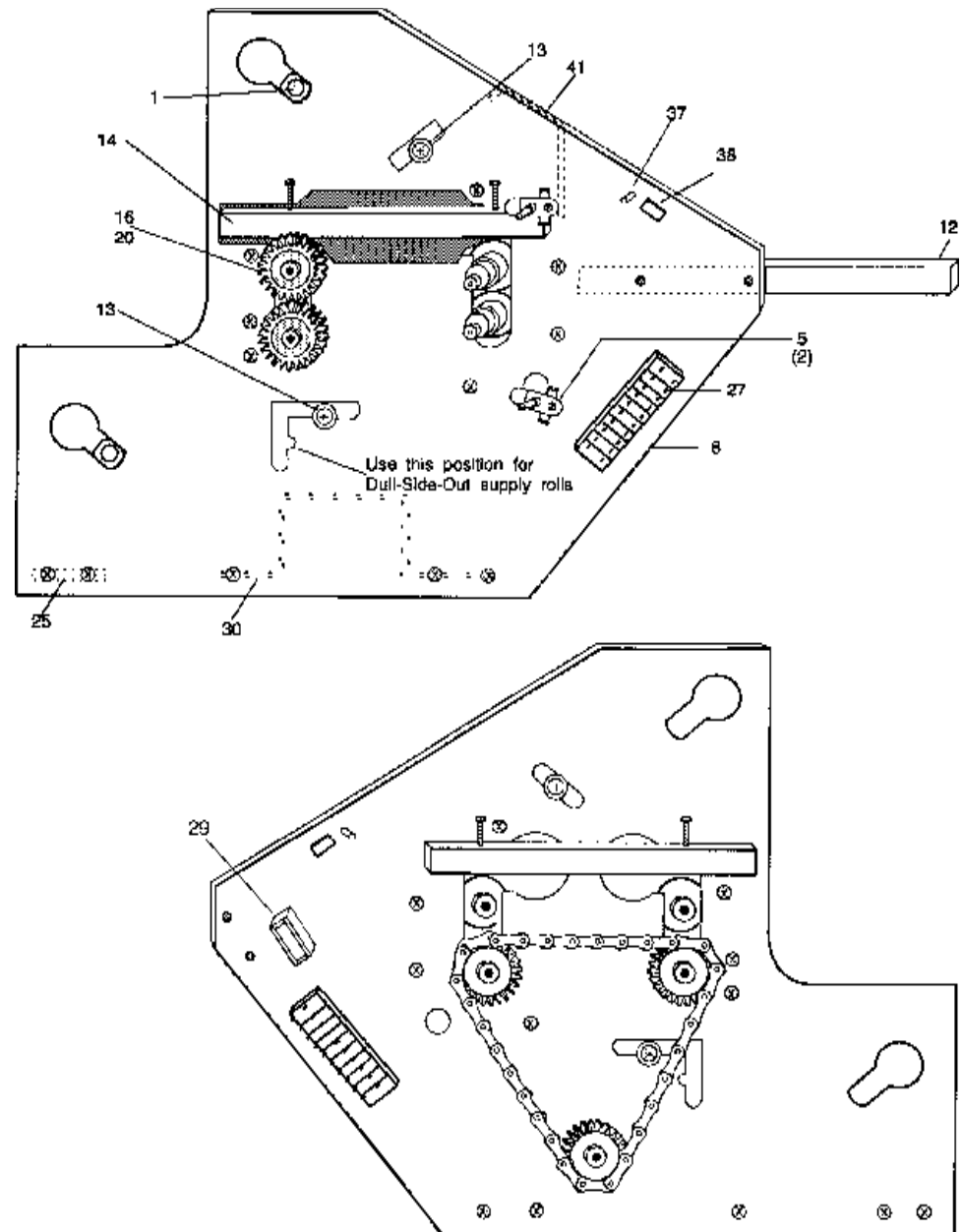

Your EZ27 is preset at the factory for most applications so any adjustments should be minor. A thermometer provides continual indication of the Heat Shoe temperature and may be adjusted as needed.

Laminator Standard Features...

- * Preset laminating roller pressure and speed require no adjustment.
- * Feed table with adjustable guide.
- * External thermometer for ease in monitoring temperature.
- * Teflon® coated Heat Shoes for easy cleaning.
- * Laminating film widths up to 27".
- * Total thickness up to 86 mils (laminates plus paper).

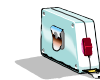
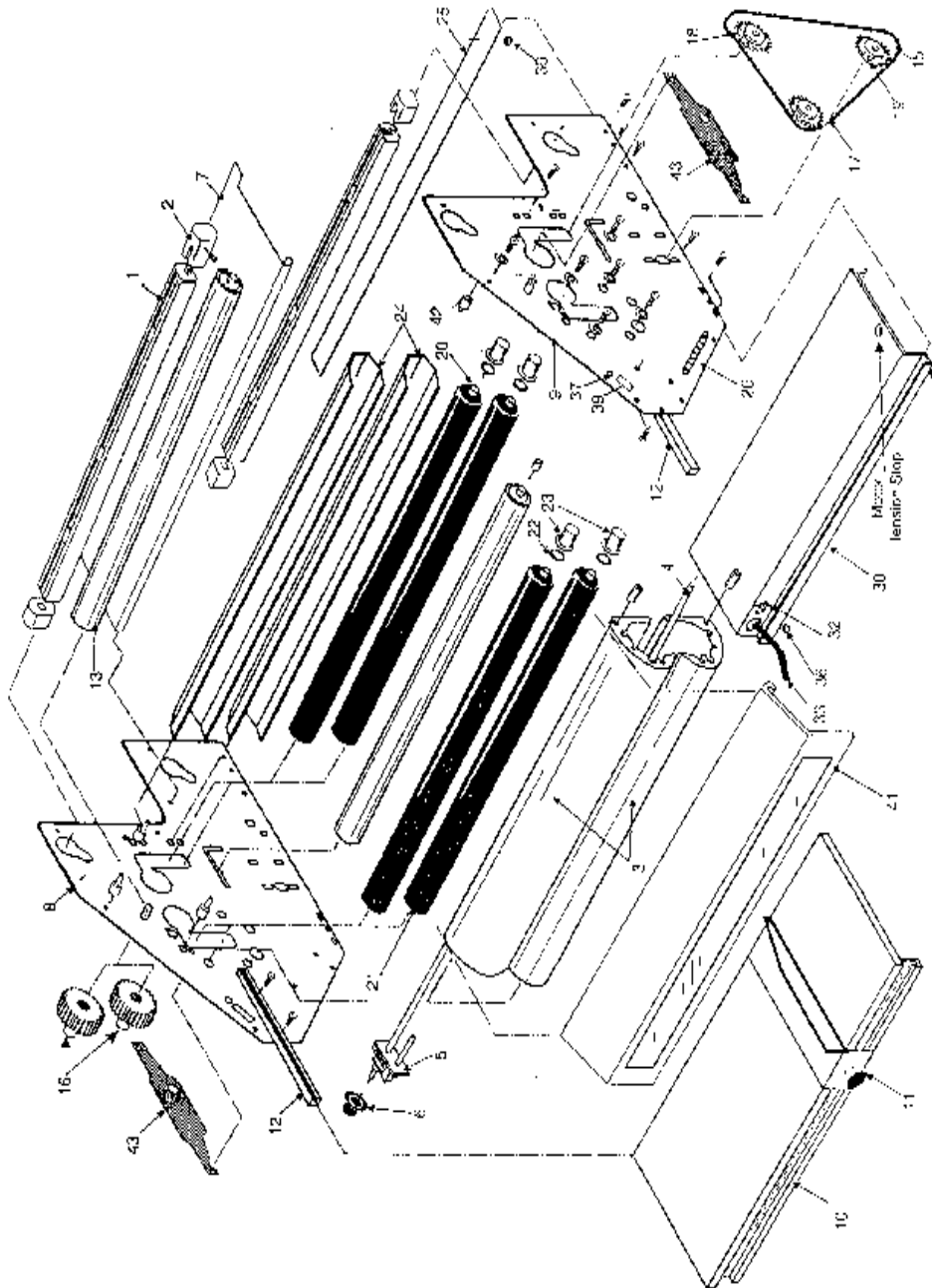

SPECIFICATIONS

Plastic Width	27" (68.6cm)
Plastic Thickness	1.5 mil and 3 mil
Maximum Roll Length	1.5 mil - 1,000 feet (304.8 meters) 3 mil - 500 feet (152.4 meters)
Speed	4 feet per minute
Net weight	66 lbs (29.96 kg)
Power Requirements	120VAC, 60Hz, 1840 watts (UL), 1360 watts (CSA) 220VAC available



INITIAL SETUP

Unpacking and assembly...

Before unpacking the unit, inspect the shipping container for signs of damage. Notify the carrier and your dealer immediately if any damage is noted.



CAUTION! The laminator, without the feed table and mounting slides installed, weighs approximately 70 lbs. Use two people when removing the laminator from the shipping container.

First unpack and identify the following items:

- EZ27 Roll Laminator
- Feed Table with Paper Guide
- Mounting Slides for Feed Table (with screws)

Assemble the Feed Table:

Before you can begin using your laminator, you will have to assemble the Feed Table and Guides on the laminator. To do this, you will need a #2 Phillips screwdriver.

1. Place the laminator on a sturdy table or stand with clear access to both side panels.
2. Place one Feed Table Slide on the left side plate and attach the Slide with two #8-32 x 1/2 screws.
3. Mount the second Slide to the right side plate using two #8-32 x 1/2 screws.

Components...

The figure below shows the location of the major components and controls of the EZ27. You should become familiar with these before operating the laminator.

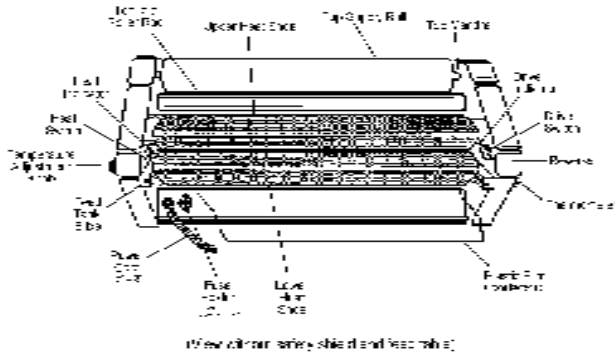

16	627601	Laminating & Pull Roll Spur Gear	2
17	600602	Roller Sprocket, front, 22 tooth	
18	600603	Roller Sprocket, rear, 21 tooth	
19	600601	Motor Gear	
20	327007	Rubber Rollers, top	2
21	327006	Rubber Rollers, bottom	2
22	700613	Spacer Washers	2/assy
23	600401	Bearing, Roller	8/assy
24	627119	Roller Cover	2
25	627108	Tie Bar	
26	500304	Terminal Block, 6 position	
28		Motor Drive Assembly	1
	700680	Mounting Washers	4
	127001	Motor, Standard	1
	100005	Motor, 90V DC, Variable Speed	1
	127002	Motor, 220V	1
	627126	Motor Support Bracket	
	700454	Mounting Screws	4
29	500002	Capacitor, 7.5µf	
30	627104	Motor Cover	
31	627306	Cover Plate	
32		Fuse Assembly	
	500401	Fuse Holder	
	500512	Fuse, 10A, 220V	
	500516	Fuse, 15A, 120V (UL)	
	500513	Fuse, 12A, 120V (CSA)	
33	500204	Power Cord	1
	227607	Strain Relief Bushing	
34	200002	Side Cover, Right	1
35	200001	Side Cover, Left	1
36	200606	Rubber Feet	4
37	500601	Indicator Lamp	2
38	500701	Heater Power Switch	1
39	500706	Machine Drive Switch	1
40	500703	Reverse Drive Switch	1
41	227107	Safety Shield	1

Zippy Cutter 1



PARTS LIST AND ILLUSTRATIONS

This section contains reference drawings and parts lists to assist you when repairing and servicing your laminator. The drawings show only those parts that may be replaced by the dealer.

Item	Part Number	Description	Qty.
1		Supply Mandrel Assembly	2
	600021	Core Gripper	1/assy.
	627110	Mandrel	2
	200616	End Bushing	1/assy
	700703	Snap Ring	2/assy
2	200611	Mandrel Brake Assembly	2
3		Heat Shoe Assembly	2
	627112	Teflon Coated Heat Shoe	2
4	527104	Heater Element	2/assy
5	500804	Thermostat	2
	700304	Heat Shoe Spacers	4/assy
6	200602	Thermostat Knobs	1
7	627305	Run-off Table	1
		Screw, #6-32 x 3/4"	2
8	600305	Aluminum Side Plate, Left	1
9	600306	Aluminum Side Plate, Right	1
10		Feed Table Assembly	1
	627117	Feed Table	1
11	600311	Feed Table Guide, Right hand	1
	200619	Adjustment Knob	1
12	627132	Feed Table Slide	2
	700441	Attaching Screws, 8-32 x 1/4", pan head	4
13		Idle Bar Assembly	2
	327011	Idle Bar Rod	1/assy
	200608	Bushings, Idle Bar	2/assy
	700495	Screws, 1/4-20 x 1/2", Socket, set	2/assy
14		Roller Tension Assembly	2
	600202	Tension Bar	1
	700504	Screws, #10-24 x 3/4" flat head	2/assy
	700478	Screws, #10-24 x 3/4" pan head	2/assy
15	900301	Roller Drive Chain & Master Link	1

Machine Drive: This three position (FWD/OFF/REV) switch controls power to the Laminating Rollers. If the switch is pressed to the FWD position the rollers move forward, pulling the plastic film and laminated material past the Heat Shoes.

When this switch is pressed to the REV position the rollers move in the reverse direction. This is useful for clearing film from the rollers.

Drive Indicator: This light remains on when the Machine Drive is moved to either FWD or REV positions.

Heater Power: This switch turns power to the top and bottom Heat Shoes on and off.

Heat Indicator: This light goes on when the Heat Switch is first turned on then remains on until the Heat Shoe reaches the operating temperature. After that point, the light will flash briefly as the thermostat controls the Heat Shoe temperature.



OPERATION

This section describes the operation of your EZ27. This laminator is designed for all widths of plastic up to 27". However, if narrower widths are used the Heat Shoes must be cleaned before using a wider roll. Refer to the MAINTENANCE section for cleaning instructions.

Loading Laminating Film onto Mandrels...

Slide the film onto the mandrel as in Figure 2 below, making sure that the mandrel spring is in position to compress properly when the film is pushed onto the mandrel. *Remove the film in the same direction.*

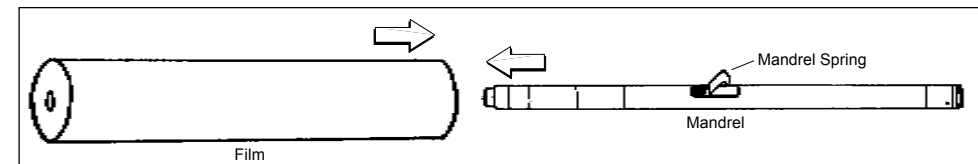

Figure 2

Threading Laminating Film...

These instructions apply to poly-in film rolls (shiny side out, dull side in)

1. For the top supply roll place the mandrel ends into the slots in the top of the laminator. If you are facing the front of the laminator the film should unwind toward you from the bottom of the roll as in Figure 3 below.

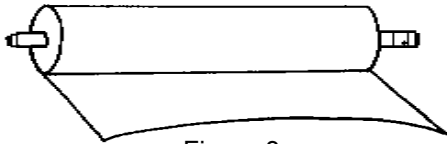

Figure 3

2. Pull 6"-12" of film from the top roll. Pass the film under the idler bar and over the heat shoes. Make sure the shiny side of the film is against the shoes. See Figures 5 & 6 below.

3. For the bottom supply roll, remove the run-off table. From the back of the laminator, place the mandrel ends into position in lower mandrel holder slots. Return the Run-off Table to its proper position before operating the laminator. If you are at the back of the laminator the film should unwind away from you at the top of the roll as in Figure 4 below.

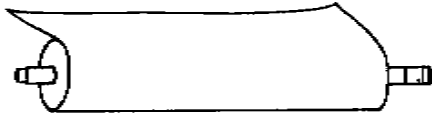

Figure 4

4. Pull 6"-12" of film from the bottom roll. Pass it under the lower idler bar and drape the film from the bottom roll over the film from the top roll. Since the heat shoes are hot the bottom film will adhere to the top film. See Figures 5 & 6 below.

Note: The shiny side of the film must always go against the Heat Shoes. If the laminating film is wound with the dull side out, the Lower Idler Bar must be moved to the lower position. To do this, remove the side covers and loosen the screws from both ends of the Idler Bar. Move the bar to the lower position and tighten both screws. Replace the side covers.



Caution: The Heat Shoes reach a temperature of up to 350°F. Do not touch the surface of the Heat Shoes.

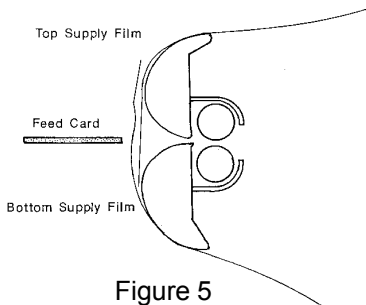

Figure 5

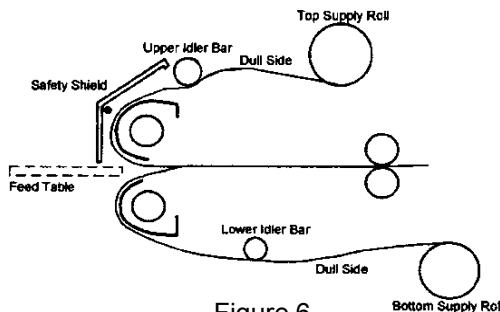

Figure 6

Note:

The surface of the Heat Shoes is Teflon® coated and must only be cleaned using a soft cloth. They can easily be damaged by sharp or abrasive objects.

1. Allow the Heat Shoes to cool.
2. Remove the Feed Table by sliding it toward you to expose the Heat Shoes.
3. Cut the plastic film from the supply rolls and where it exits the rollers. Pull the film toward you and away from the rollers.
4. Lift the film away from the Heat Shoes. Turn the power on and hold the Motor Drive switch in the REV position while pulling the film forward toward you (from the front of the laminator).
5. Use a soft cloth moistened with alcohol to remove any residue from the Teflon® surface of the Heat Shoes and Laminating Rollers.
6. Allow the Heat Shoes and Laminating Rollers to dry before re-threading the film.

Removing Wrap-arounds...

When laminating with thinner gauges of film, there is the possibility of the film wrapping around the Pull Rollers. Use the same procedure for **Cleaning the Heat Shoes and Laminating Rollers** in order to remove a wrap-around. You should remove any wrap-arounds that occur as soon as possible. If the film is allowed to cool while wrapped around the rollers it may be more difficult to remove and the heat shoes may have to be turned on to loosen the film.

Note:

The heat shoes are hot! Use caution when cleaning the rollers or heat shoes, or when removing wrap-arounds.



WARRANTY AND RETURN POLICY

Warranty

Your laminator is warranted to be free of defects in material and workmanship for a period of 1 year from the date of original purchase. In the event of a defect in material or workmanship, the manufacturer or its authorized dealer, will repair or replace (at their option) the laminator. This does not cover rollers that have been damaged due to improper cleaning. The manufacturer makes no other warranty stated or implied except as stated above.

Return Policy

If your laminator is not operating properly, first review the Operating Instructions and Troubleshooting Guide. If the malfunction cannot be corrected, contact your local dealer for instructions. Be sure to have your machine serial number and date of purchase handy. If the laminator must be returned to the dealer, *proper packaging and freight charges are your responsibility*. Shipping damage as a result of improper packaging is not covered under the terms of this warranty.

PROBLEM: *Stretch lines appear on laminated items running parallel with the outside edges.*

ACTION: Increase roller tension on top and/or bottom supply rolls.

Reduce heat shoe temperature.

Clean heat shoes of residual adhesive. See MAINTENANCE section for cleaning instructions.

PROBLEM: *Blistering of the film appears over the item or along the edge.*

ACTION: Reduce temperature on one or both heat shoes. If the indicator light remains on after the adjustment is made, disconnect the power supply and contact your dealer.

Clean laminating rollers. See MAINTENANCE section for cleaning instructions.

There may be moisture in the paper you are laminating. Store paper in a dry place and be sure that any ink is thoroughly dry before laminating.

PROBLEM: *Laminated material curls after leaving pull rollers.*

ACTION: Adjust tension. If laminated item curls upwards, reduce top roller tension. If item curls downward, reduce bottom roller tension.

Clean heat shoes of residual adhesive as it may be causing "drag" on one side. Refer to MAINTENANCE section for cleaning instructions.



MAINTENANCE

This section contains instructions for cleaning and maintaining your laminator. These procedures should be performed at regular intervals to help ensure the trouble-free operation of your laminator.



Caution:

Before performing any maintenance on your laminator first disconnect the power supply. Hazardous voltages are present when the side panels are removed.

Cleaning the Heat Shoes and Laminating Rollers...

The Heat Shoes and Laminating Rollers should be cleaned of any residual adhesive whenever the film does not pass smoothly over their surfaces.

8. Turn the Machine Drive switch to FWD to start the Laminating and Pull Rollers.

9. Feed a piece of thin cardboard about 10" x 25" against the film so that it is centered between the two Heat Shoes. Push the cardboard and film into the Laminating Rollers. See figure 4.

10. When the feed card has completely exited the Pull Rollers at the rear of the laminator turn the Machine Drive Switch off.

11. Insert the Feed Table into the slots located on each side of the unit, between the Heat Shoes.

12. If you are not ready to laminate, turn the Heat Switch off.

Adjusting Mandrel/Film Tension...

Each type of laminating film has different characteristics and may require laminator adjustment. The tension should be set so that the film moves over the Heat Shoes without wrinkles as the film enters the laminator. Best results are obtained if tension adjustments are made while the unit is at operating temperature. If any adjustments are required use the following procedure:

1. Switch the Heaters on. Wait for the Heat Shoes to reach operating temperature. The indicator lamp will go off when the proper temperature is reached. You can check the temperature by reading the thermometer located on the right side of the laminator.

2. Press the Machine Drive switch to FWD.

3. Locate knob on the right side of Top Supply Mandrel. Turn the knob to adjust the tension (clockwise to increase, counter clockwise to decrease) until the film passes over the Top Heat Shoe without wrinkles and the web between the laminating and pull rollers is tight. *Note: This adjustment requires only a few degrees of turn. If the knob is turned too far clockwise, you may stall the drive motor.*

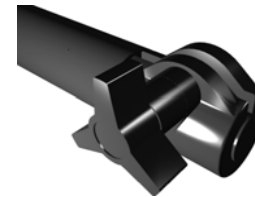

4. Repeat for Bottom Supply Mandrel.

5. If you are not ready to laminate, turn the Machine Drive and Heat Switches off.

Setting Heat Shoe Temperature...

The laminator temperature should be adjusted according to the film thickness and the item being laminated. See Table 1 below for recommended temperature settings. *Keep in mind that the temperatures listed are approximate and different brands of laminating film may require different temperatures.*

1. Turn the Heater switch on.
2. Use the Heater Thermostat Adjustment Knob on the left side of the laminator to adjust the temperature of the Heat Shoes. Use the temperatures in Table 1 below as a guide.

Material	Temperature Range
1.5 mil (.0015")	310°F - 325°F
3 mil (.003")	250°F - 265°F

Table 1

3. Turn the knob counter clockwise to reduce the temperature and clockwise to increase the temperature. If reducing the temperature, wait several minutes for the heat to drop to the proper operating temperature. When increasing temperature, the indicator lamp will come on as the laminator is heating up and go off when it reaches operating temperature.
4. Check the thermometer to see if the desired temperature has been reached. You may have to make a few minor adjustments before optimum temperature is set.



LAMINATING

1. Be sure the heaters have been turned on and are at the proper temperature. Be sure the film has been properly threaded.



Caution: Do not allow the temperature to exceed 350°F as this could cause the laminating film to melt on the Heat Shoes.

2. Adjust the Paper Guide on the Feed Table so that the right edge of the item will enter the laminator at the desired position.
3. Press the Machine Drive switch to the FWD position. The film will begin moving through the laminator.
4. After clear laminating film exits the Pull Rollers at the rear of the machine you may slide the first item to be laminated into the laminator with the right edge along the Paper Guide.

Note:

You may want to run a test lamination first as any item that passes between the Heat Shoes will be laminated and cannot be recovered until it exits the rear of the laminator.

5. Additional items may be fed in sequence, keeping enough distance between sheets for trimming.
6. After the last item has exited the Pull Rollers, turn the Machine Drive switch off.
7. Use the Zippy Cutter to cut across the film to remove the laminated items from the unit.



TROUBLESHOOTING

The following guide will assist you with most problems that may be encountered when laminating.

PROBLEM: *Laminator is inoperative. Motor does not turn, indicator lights are out.*

ACTION: Unit may be unplugged. Connect power supply

Ensure that the circuit breaker has not tripped

Fuse may have blown. Replace fuse (front next to power cord) with 15 amp BUSS (MDA-15) for standard units, or 12 amp (MDA-12) for CSA units.

PROBLEM: *Laminating film and item being laminated move through laminator erratically.*

ACTION: Check thickness of item to be laminated. Maximum thickness is 1/16" (1.6mm).

Clean heat shoes of residual adhesive. Refer to MAINTENANCE section for cleaning instructions.

PROBLEM: *Plastic is not bonding to the item or to itself at the edges.*

ACTION: Make sure heat shoes and rollers are at proper operating temperature and have had time to warm up. See Table 1 for the suggested temperature ranges.

PROBLEM: *Wrinkles on laminated item running parallel with supply rolls.*

ACTION: Increase roller tension on top and/or bottom supply rolls; only small amounts between tests.

Reduce heat shoe temperature.